

CALIFORNIA PROPOSITION 65 WARNING

WARNING

Operating, servicing and maintaining a passenger vehicle or off-highway motor vehicle can expose you to chemicals including engine exhaust, carbon monoxide, phthalates, and lead, which are known to the State of California to cause cancer and birth defects or other reproductive harm. To minimize exposure, avoid breathing exhaust, do not idle the engine except as necessary, service your vehicle in a well-ventilated area and wear gloves or wash your hands frequently when servicing your vehicle. For more information go to www.P65Warnings.ca.gov/passenger-vehicle.

Foreword

This manual was prepared to help you understand the operation and maintenance of your vehicle so that you may enjoy many miles of driving pleasure. Please read through this manual before operating your vehicle.

A separate Warranty and Maintenance Manual explains details about the warranties covering your vehicle.

In addition to factory installed options, your vehicle may also be equipped with additional accessories installed by Mitsubishi Motors or by your authorized Mitsubishi Motors dealer prior to delivery. It is important that you familiarize yourself with all disclosures, warnings, cautions and instructions concerning proper use of such accessories prior to operating the vehicle and/or accessory. It is recommended you see an authorized Mitsubishi Motors dealer for details concerning the particular accessories with which your vehicle is equipped.

Your authorized Mitsubishi Motors dealer knows your vehicle best. When you require any service or have any questions, we will be glad to assist you with the extensive resources available to us.

READ FIRST — THEN DRIVE SAFELY

Before driving your vehicle, read your Owner's Manual carefully. This will ensure familiarity with controls and maintenance requirements, assisting you in the safe operation of your vehicle.

WARNING

IMPORTANT SAFETY INFORMATION REMINDERS!

Follow these important driving rules to help ensure a safe and comfortable trip for you and your passengers!

- NEVER drive under the influence of alcohol or drugs.
- ALWAYS observe posted speed limits and never drive too fast for conditions.
- ALWAYS give your full attention to driving and avoid using vehicle features or taking other actions that could distract you.
- ALWAYS use your seat belts and appropriate child restraint systems. Pre-teen children should be seated in the rear seat.
- ALWAYS provide information about the proper use of vehicle safety features to all occupants of the vehicle.

- ALWAYS review this Owner’s Manual for important safety information.

On-pavement and off-road driving

This vehicle will handle and maneuver differently from an ordinary passenger car because it has a higher center of gravity. As with other vehicles with features of this type, failure to operate this vehicle correctly may result in loss of control or an accident. Be sure to read “Avoiding collision and rollover” and “Driving safety precautions” in the “5. Starting and driving” section of this manual.

MODIFICATION OF YOUR VEHICLE

This vehicle should not be modified. Modification could affect its performance, safety or durability, and may even violate governmental regulations. In addition, damage or performance problems resulting from modification may not be covered under Mitsubishi Motors warranties.

WARNING

Installing an aftermarket On-Board Diagnostic (OBD) plug-in device that uses the port during normal driving, for example remote insurance company monitoring, remote vehicle diagnostics, telematics or engine reprogramming, may cause interference or damage to vehicle systems. We do not recommend or endorse the use of any aftermarket OBD plug-in devices, unless specifically approved by Mitsubishi Motors. The vehicle warranty may not cover damage caused by any aftermarket plug-in device.

WHEN READING THE MANUAL

This manual includes information for all features and equipment available on this model. Features and equipment in your vehicle may vary depending on model, trim level, options selected, order, date of production, region or availability. Therefore, you may find information about features or equipment that are not included or installed on your vehicle.

All information, specifications and illustrations in this manual are those in effect at the time of printing. Mitsubishi Motors reserves the right to change specifications, performance, design or component suppliers without notice and without

obligation. From time to time, Mitsubishi Motors may update or revise this manual to provide Owners with the most accurate information currently available. Please carefully read and retain with this manual all revision updates sent to you by Mitsubishi Motors to ensure you have access to accurate and up-to-date information regarding your vehicle. If you have questions concerning any information in your Owner’s Manual, contact an authorized Mitsubishi Motors dealer.

IMPORTANT INFORMATION ABOUT THIS MANUAL

You will see various symbols in this manual. They are used in the following ways:

WARNING

This is used to indicate the presence of a hazard that could cause death or serious personal injury. To avoid or reduce the risk, the procedures must be followed precisely.

CAUTION

This is used to indicate the presence of a hazard that could cause minor or moderate personal injury or damage to your vehicle. To

avoid or reduce the risk, the procedures must be followed carefully.

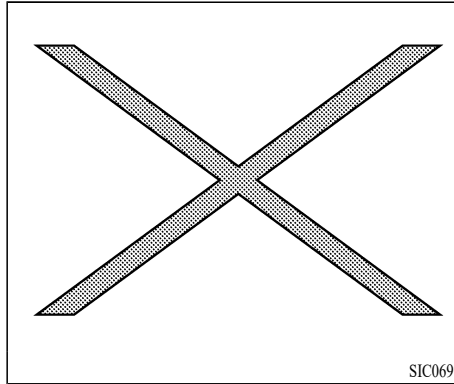

If you see the symbol above, it means “Do not do this” or “Do not let this happen”.

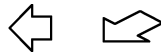

If you see a symbol similar to those above in an illustration, it means the arrow points to the front of the vehicle.

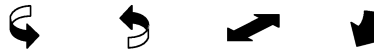

Arrows in an illustration that are similar to those above indicate movement or action.



Arrows in an illustration that are similar to those above call attention to an item in the

illustration.

CALIFORNIA PERCHLORATE ADVISORY

Some vehicle parts, such as lithium batteries, may contain perchlorate material. The following advisory is provided: “Perchlorate Material - special handling may apply, see www.dtsc.ca.gov/hazardouswaste/perchlorate.”

© 2020 Mitsubishi Motors Corporation

All rights reserved. No part of this Owner’s Manual may be reproduced or stored in a retrieval system, or transmitted in any form, or by any means, electronic, mechanical, photocopying, recording or otherwise, without the prior written permission of Mitsubishi Motors Corporation.

Table of Contents

Illustrated table of contents	0
Safety — Seats, seat belts and supplemental restraint system	1
Instruments and controls	2
Pre-driving checks and adjustments	3
Monitor, heater, air conditioner, audio and phone systems	4
Starting and driving	5
In case of emergency	6
Appearance and care	7
Do-it-yourself	8
Maintenance and schedules	9
Technical and consumer information/Reporting Safety Defects	10
Index	11

(2,1)

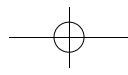
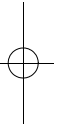
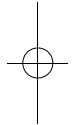
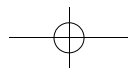

0 Illustrated table of contents

Seats, seat belts and Supplemental Restraint System (SRS)	0-2	Meters and gauges	0-8
Exterior front	0-3	Model with Combination meter cluster / Multi-information display (Type 1)	0-8
Exterior rear	0-4	Model with full digital driver display (Type 2)	0-9
Passenger compartment	0-5	Engine compartment	0-10
Cockpit	0-6	PR25DD engine model	0-10
Instrument panel	0-7	Warning and indicator lights	0-11

SEATS, SEAT BELTS AND SUPPLEMENTAL RESTRAINT SYSTEM (SRS)

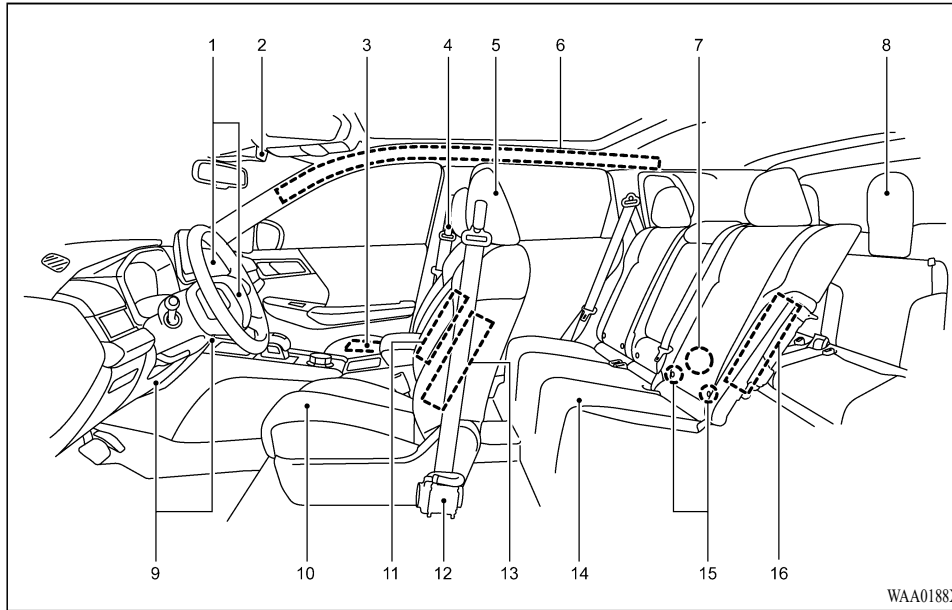

- 13. Front seat-mounted SRS side airbags (P.1-47)
- 14. Second row seats (P.1-6)
- 15. LATCH (Lower Anchors and Tethers for Children) system (for second row seats) (P.1-29)
- 16. Second-row outboard seat-mounted SRS side airbags (P.1-47)

*: if so equipped

- | | |
|--|---|
| 1. Front SRS airbags (P.1-47) | 7. Child restraint anchor point (for top tether strap) (P.1-31) |
| 2. Front passenger airbag status light (P.1-55) | 8. Third row seats (P.1-9) |
| 3. Occupant classification sensors (weight sensors) (P.1-47) | 9. Driver and passenger SRS knee airbags (P.1-47) |
| 4. Seat belts (P.1-16) | 10. Front seats (P.1-3) |
| 5. Head restraints (P.1-12) | 11. Front seat-mounted SRS center airbag* (P.1-47) |
| 6. Side Curtain SRS airbags (P.1-47) | 12. Seat belt pretensioner (P.1-69) |

0-2 Illustrated table of contents

EXTERIOR FRONT

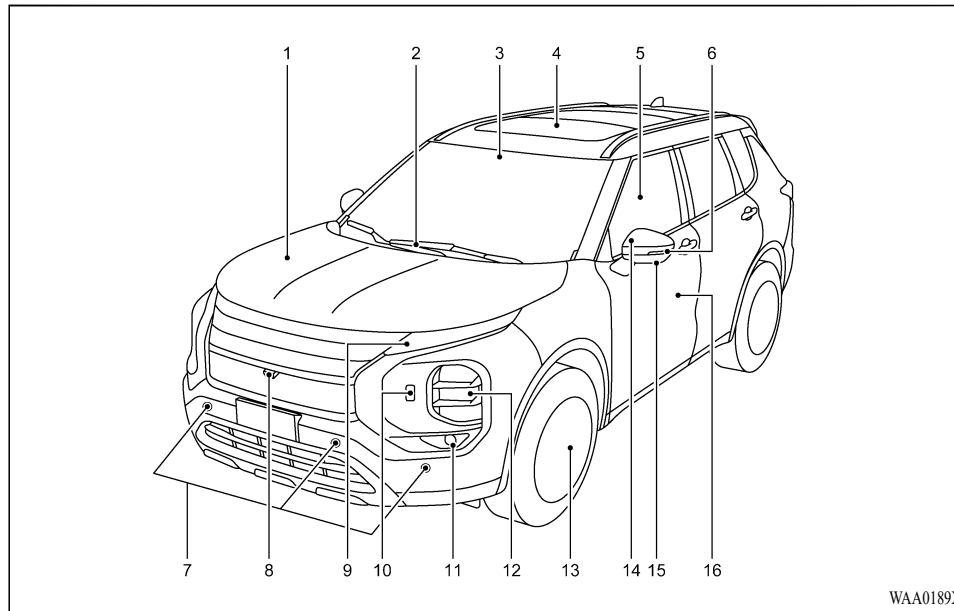

- | | |
|--|--|
| 1. Hood (P.3-19) | 5. Power windows (P.2-75) |
| 2. Windshield wiper and washer
— Switch operation (P.2-48)
— Window washer fluid (P.8-10)
— Windshield wiper deicer* (P.2-53) | 6. Side turn signal light (P.2-59) |
| 3. Front camera* (P.5-33, P.5-38, P.5-90, P.5-126) | 7. Front parking sensor* (P.5-164) |
| 4. Sunroof* (P.2-78) | 8. Front view camera* (P.4-9) |
| | 9. Daytime running lights/parking lights and front turn signal lights (P.2-53) |
| | 10. Headlight cleaners* (P.2-58) |

- | |
|---|
| 11. Fog lights* (P.2-59) |
| 12. Headlights (P.2-53) |
| 13. Tires
— Wheels and tires (P.8-24, P.10-8)
— Flat tire (P.6-3)
— Tire Pressure Monitoring System (TPMS) (P.2-17, P.5-6) |
| 14. Door mirrors (P.3-34) |
| 15. Side view camera* (P.4-9) |
| 16. Doors
— Keys (P.3-2)
— Door locks (P.3-4)
— Free-hand Advanced Security Transmitter (F.A.S.T.-key) (P.3-7)
— Security system (P.2-46) |

*: if so equipped

Illustrated table of contents 0-3

EXTERIOR REAR

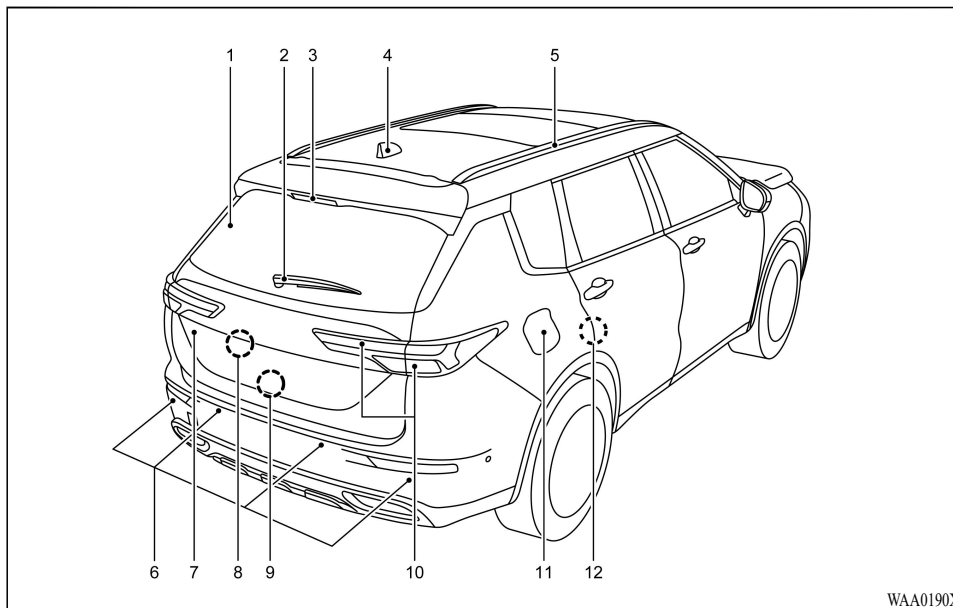

- | | |
|--|---|
| 1. Electric rear window defroster (P.2-52) | 6. Rear parking sensor |
| 2. Rear window wiper | — Parking sensor system* (P.5-164) |
| — Switch operation (P.2-51) | — Rear parking sensor System* (P.5-169) |
| — Window washer fluid (P.8-10) | — Rear Automatic Emergency Braking (Rear AEB) (P.5-146) |
| 3. High-mounted stop light (P.8-22) | 7. Liftgate (P.3-20) |
| 4. Antenna (P.4-34) | — Free-hand Advanced Security Transmitter |
| 5. Roof rail* (P.2-74) | |

(F.A.S.T.-key) (P.3-7)

- | |
|---|
| 8. Rearview camera* (P.4-2, P.4-9) |
| 9. Fuel filler funnel (under the cargo area floor) (P.3-31) |
| 10. Tail lights/stop lights/Rear turn signal lights and Back-up lights (P.8-22) |
| 11. Fuel filler door (P.3-28) |
| — Fuel information (P.10-3) |
| 12. Child safety rear door locks (P.3-6) |

*: if so equipped

0-4 Illustrated table of contents

PASSENGER COMPARTMENT

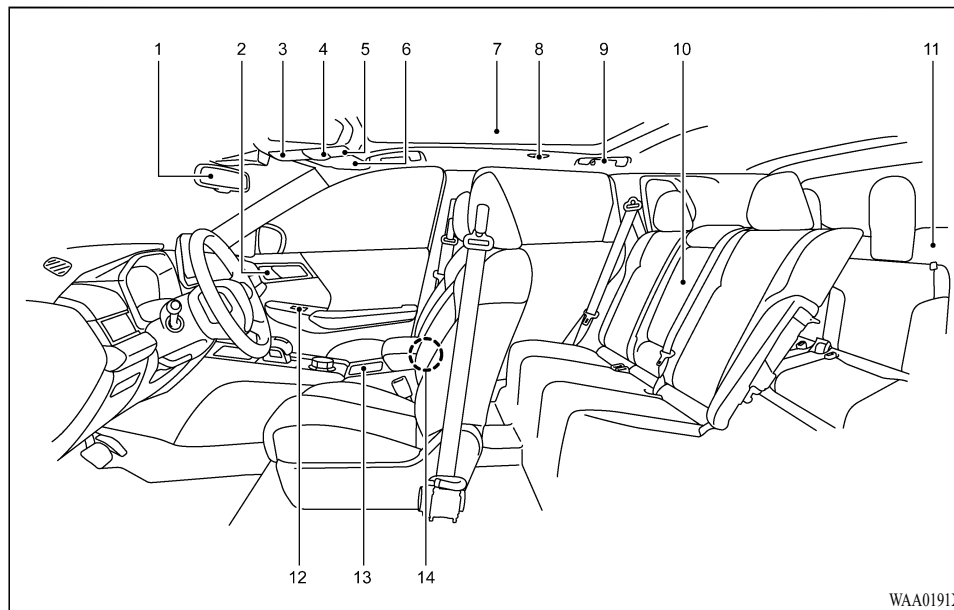

- | | |
|---|-----------------------------|
| 1. Inside mirror (P.3-33) | 5. Sunroof switch* (P.2-78) |
| 2. Driver memory settings switch* (driver's side door) (P.3-37) | 6. Sunvisors (P.3-32) |
| 3. Sunglasses holder (P.2-71) | 7. Dome light* (P.2-81) |
| 4. Map lights (P.2-80) | 8. Personal light* (P.2-81) |
| — Microphone** | 9. Coat hook (P.2-72) |
| — SOS switch* (P.2-67) | 10. Rear armrest (P.1-9) |
| | — Rear cup holders (P.2-68) |

- | |
|---|
| 11. Cargo area |
| — Storage (P.2-69) |
| — Luggage hooks (P.2-72) |
| — Tonneau cover* (P.2-73) |
| — Power outlet (P.2-63) |
| — Cargo room light (P.2-82) |
| 12. Door armrest |
| — Power window switch (P.2-75) |
| — Power door lock switch (driver's side door) (P.3-6) |
| — Door mirror remote control switch (driver's side door) (P.3-34) |
| 13. Front cup holders (P.2-68) |
| 14. Console box (P.2-70) |
| — USB (Universal Serial Bus) charging connector* (P.2-64) |

*: if so equipped

** : Refer to the separate Smartphone-link Display Audio (SDA) Owner's Manual.

Illustrated table of contents 0-5

COCKPIT

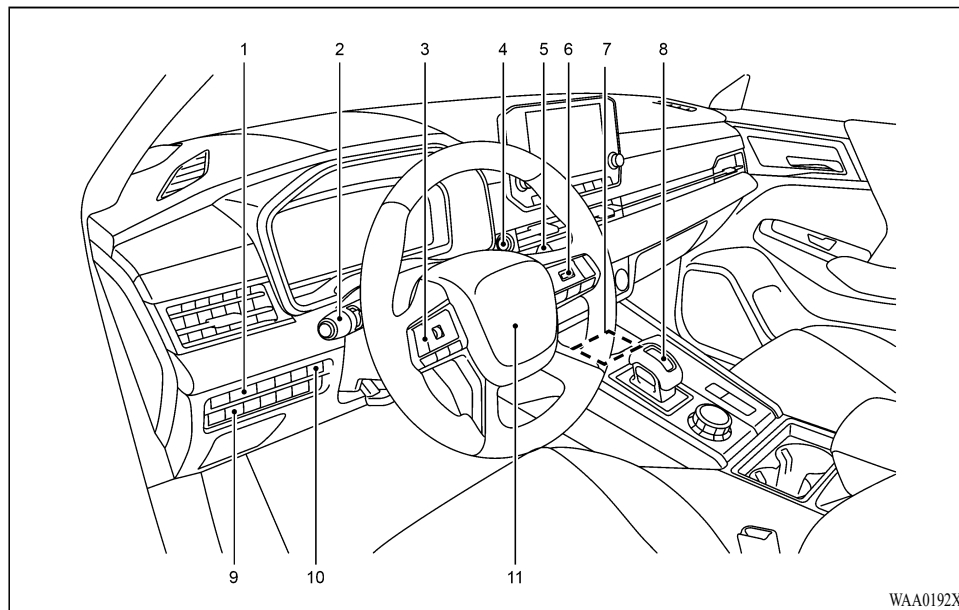

- | | |
|---|--|
| 1. Instrument brightness control (P.2-11) | 4. Push-button ignition switch (P.5-13) |
| 2. Headlight and turn signal switch (P.2-53)/Fog light switch* (P.2-59) | 5. Wiper and washer switch (P.2-48) |
| 3. Steering wheel remote control switches (left side) | 6. Steering wheel remote control switches (right side) |
| — Audio control** | — Cruise control* (P.5-69) |
| — Multi-information display control (P.2-21) | — Adaptive Cruise Control System (ACC)* (P.5-71) |

- MI-PILOT Assist* (P.5-90)
 - Bluetooth® Hands-Free Phone System**
 - Voice Recognition system switch**
7. Wireless charger* (P.2-64)
8. Shift lever
- Continuously Variable Transmission (CVT) (P.5-17)
9. Head-Up Display (HUD) switch* (P.2-43)
10. Power liftgate switch* (P.3-20)
11. Steering wheel (P.3-31)
- Horn (P.2-60)
- *: if so equipped
- ** : See the separate Smartphone-link Display Audio (SDA) Owner's Manual.

0-6 Illustrated table of contents

INSTRUMENT PANEL

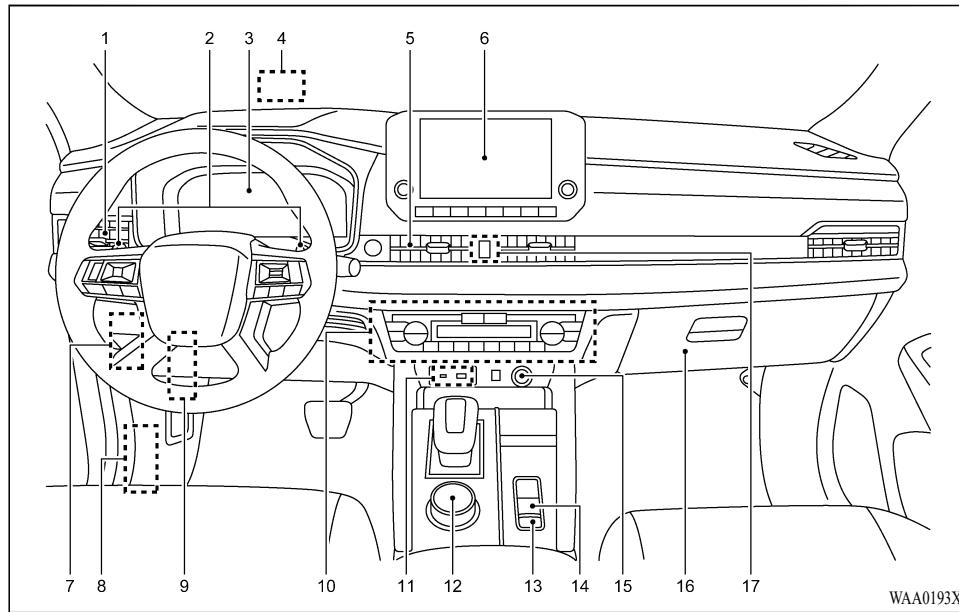

- | | |
|---|---|
| 1. Side ventilator (P.4-27) | — Multi Around Monitor* (P.4-9) |
| 2. Steering wheel paddle shifter (P.5-21) | — Bluetooth® Hands-Free Phone System** |
| 3. Meters and gauges (P.2-5)/Clock (P.2-43) | |
| 4. Head-Up Display (HUD)* (P.2-43) | 7. Fuse box cover (P.8-18) |
| 5. Center ventilator (P.4-26) | 8. Hood release handle (P.3-19) |
| 6. Audio system** or navigation system** | 9. Steering wheel lock lever (P.3-31) |
| — Rearview camera* (P.4-2) | 10. Heater/air conditioner control (P.4-28) |
| | — Defroster switch (P.2-52) |

- Windshield deicer switch* (P.2-53)
 - Heated seat switch* (P.2-61)
 - Heated steering wheel switch* (P.2-60)
 - 11. USB (Universal Serial Bus) input terminal**
 - 12. Drive mode selector (P.5-28)
 - Hill Descent Control switch (P.5-162)
 - 13. Brake Auto Hold switch (P.5-25)
 - 14. Parking brake switch (P.5-23)
 - 15. Power outlet (P.2-63)
 - 16. Glove box (P.2-70)
 - 17. Hazard indicator flasher switch (P.6-2)
- *: if so equipped
 **: See the separate Smartphone-link Display Audio (SDA) Owner's Manual.

Illustrated table of contents 0-7

METERS AND GAUGES

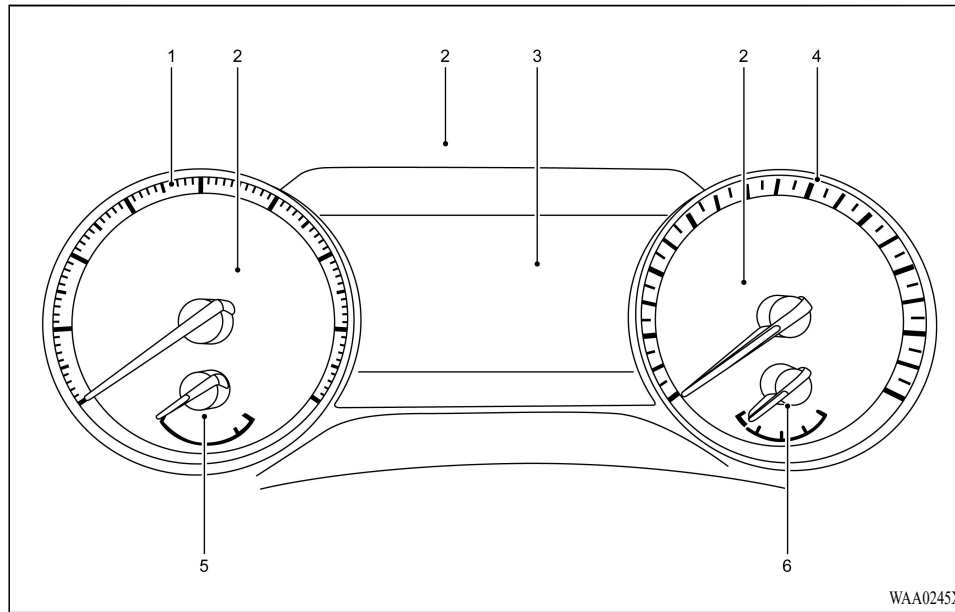

MODEL WITH COMBINATION METER CLUSTER / MULTI- INFORMATION DISPLAY (Type 1)

1. Tachometer (P.2-9)
2. Warning/indicator lights (P.2-12)
3. Multi-information display (P.2-21)
— Distance to empty/Odometer (P.2-8)
4. Speedometer (P.2-8)
5. Engine coolant temperature gauge (P.2-9)
6. Fuel gauge (P.2-10)

0-8 Illustrated table of contents

Condition:

[Edit: 2021/ 2/ 10 Model: DG-D]

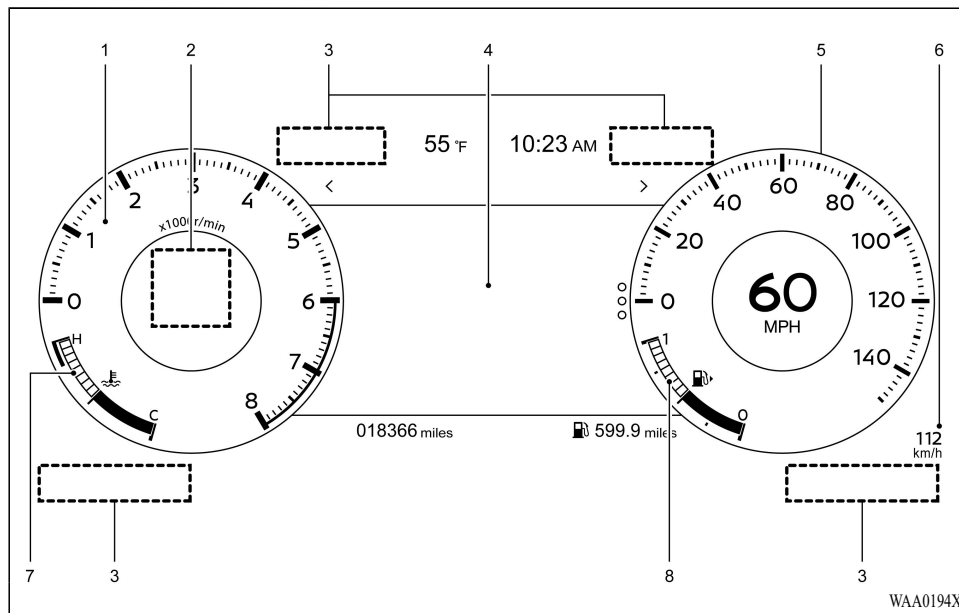

MODEL WITH FULL DIGITAL DRIVER DISPLAY (Type 2)

- | | |
|--|---|
| <ol style="list-style-type: none"> 1. Tachometer (P.2-9) 2. Personal display (P.2-22) 3. Warning/indicator lights (P.2-12) 4. Multi-information display (P.2-21) | <p>— Distance to empty/Odometer (P.2-8)</p> <ol style="list-style-type: none"> 5. Speedometer (P.2-8) 6. Secondary speedometer (P.2-8) 7. Engine coolant temperature gauge (P.2-9) 8. Fuel gauge (P.2-10) |
|--|---|

Illustrated table of contents 0-9

ENGINE COMPARTMENT

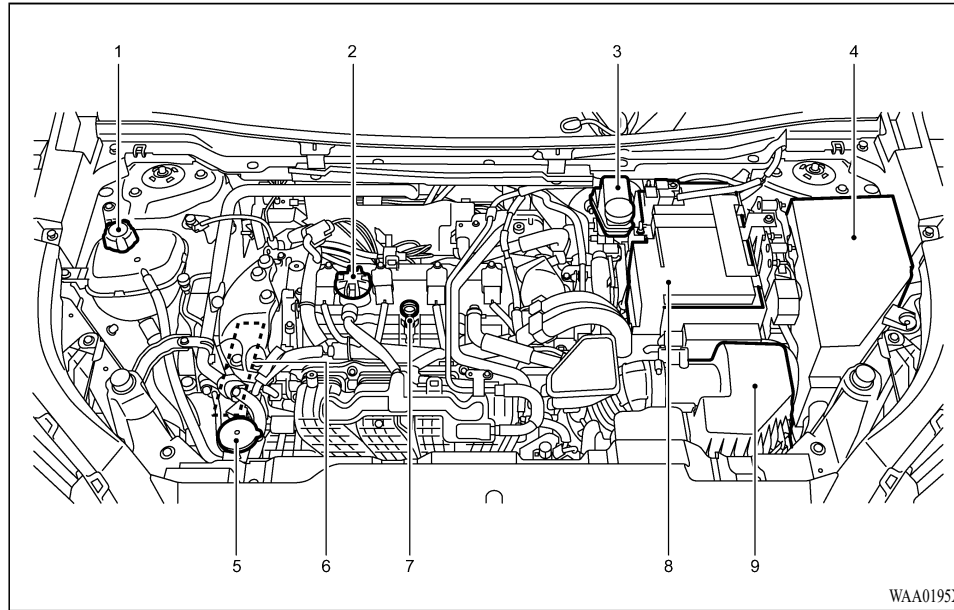























PR25DD ENGINE MODEL







- | | |
|---|--------------------------------|
| 1. Engine coolant reservoir (P.8-5) | 6. Drive belt (P.8-13) |
| 2. Engine oil filler cap (P.8-6) | 7. Engine oil dipstick (P.8-6) |
| 3. Brake fluid reservoir (P.8-9) | 8. Battery (P.8-11) |
| 4. Fuse/fusible link box (P.8-17) | 9. Air cleaner (P.8-14) |
| 5. Window washer fluid reservoir (P.8-10) | |

0-10 Illustrated table of contents

WARNING AND INDICATOR LIGHTS

Red light	Name	Page
	Brake warning light	2-13
		
	Charge warning light	2-14
	Electric shift control system warning light	2-14
	Electronic parking brake warning light	2-14
		
	Engine oil pressure warning light	2-14
	Front seat belt warning light	2-15
	Hands OFF warning light (if so equipped)	2-15
	Master warning light	2-15
	SRS airbag warning light	2-15

Yellow light	Name	Page
	Active stability control (ASC) warning light	2-16
	Active stability control (ASC) off indicator light	2-16
	Anti-lock Braking System (ABS) warning light	2-16
		
	Forward Collision Mitigation System (FCM) OFF warning light	2-16
	Electric power steering warning light	2-16
	Electronic parking brake warning light	2-17
	Low tire pressure warning light	2-17
	Malfunction Indicator Light (MIL)	2-18
	Master warning light	2-19
	Rear Automatic Emergency Braking (Rear AEB) system OFF warning light	2-19

Other light	Name	Page
	Automatic High Beam (AHB) indicator light	2-19
	Brake Auto Hold indicator light (white)	2-19
	Brake Auto Hold indicator light (green)	2-19
	Exterior light indicator	2-19
	Front fog light indicator light (if so equipped)	2-19
	High beam indicator light	2-20
	Turn signal/hazard indicator lights	2-20

Illustrated table of contents 0-11

MEMO

0-12 **Illustrated table of contents**

Condition:

[Edit: 2021/ 2/ 10 Model: DG-D]

1 Safety — Seats, seat belts and supplemental restraint system

Seats	1-2	Lower Anchors and Tethers for CHildren (LATCH) system	1-29
Front seats	1-3	Rear-facing child restraint installation using LATCH	1-31
Second row seats	1-6	Rear-facing child restraint installation using the seat belts	1-33
Third row seats	1-9	Forward-facing child restraint installation using LATCH	1-36
Head restraints	1-12	Forward-facing child restraint installation using the seat belts	1-39
Adjustable head restraint components	1-13	Booster seats	1-43
Non-adjustable head restraint components	1-13	Supplemental Restraint System (SRS)	1-47
Remove	1-14	Precautions on SRS	1-47
Install	1-14	Advanced Airbag System (front seats)	1-53
Adjust	1-14	Driver and front passenger SRS knee airbag	1-62
Seat belts	1-16	Front and second row seat-mounted side airbag, front seat-mounted center airbag and side curtain SRS airbag systems	1-63
Precautions on seat belt usage	1-16	SRS airbag deployment conditions	1-65
Seat belt warning light and chime	1-19	Seat belts with pretensioners (front and second row outboard seats)	1-69
Pregnant women	1-20	Airbag warning labels	1-70
Injured persons	1-20	SRS airbag warning light	1-71
Three-point type seat belt with retractor	1-20	Repair and replacement procedure	1-71
Seat belt extenders	1-23		
Seat belt maintenance	1-24		
Child safety	1-24		
Infants	1-25		
Small children	1-25		
Larger children	1-25		
Child restraints	1-27		
Precautions on child restraints	1-27		

SEATS

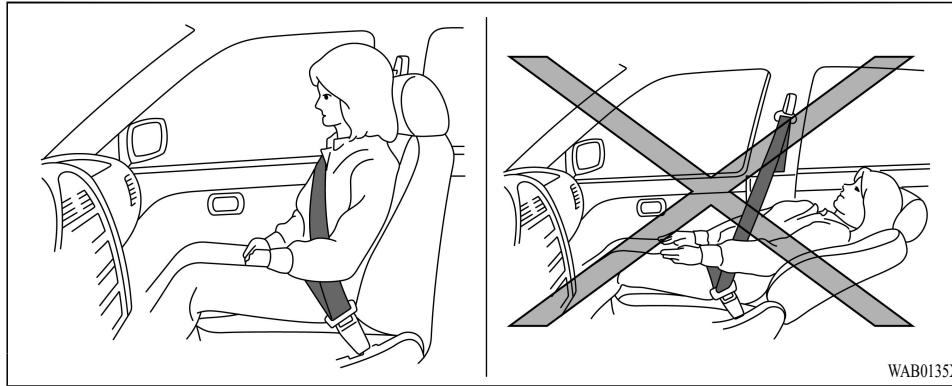

WARNING

- Do not place objects under the seats. This could prevent the seat from locking securely, and it could lead to an accident. It may also cause damage to the seat or other parts.
- Do not ride in a moving vehicle when the seatback is reclined. This can be dangerous. The shoulder belt will not be against your body. In an accident, you could be thrown into it and receive neck or other serious injuries. You could also slide under the lap belt and receive serious internal injuries.

- For the most effective protection when the vehicle is in motion, the seat should be upright. Always sit well back and upright in the seat with both feet on the floor and adjust the seat properly. See “Precautions on seat belt usage” (P.1-16).
- After adjustment, gently rock in the seat to make sure it is securely locked.
- Do not leave children unattended inside the vehicle. They could unknowingly activate switches or controls. Unattended children could become involved in serious accidents.
- To help avoid risk of injury or death through unintended operation of the vehicle and/or its systems, do not leave

children, people who require the assistance of others or pets unattended in your vehicle. Additionally, the temperature inside a closed vehicle on a warm day can quickly become high enough to cause a significant risk of injury or death to people and pets.

- Do not adjust the driver’s seat while driving so full attention may be given to vehicle operation. The seat may move suddenly and could cause loss of control of the vehicle.
- The seatback should not be reclined any more than needed for comfort. Seat belts are most effective when the passenger sits well back and straight up in the seat. If the seatback is reclined, the risk of sliding under the lap belt and being injured is increased.

CAUTION

When adjusting the seat positions, be sure not to contact any moving parts to avoid possible injuries and/or damage.

1-2 Safety — Seats, seat belts and supplemental restraint system

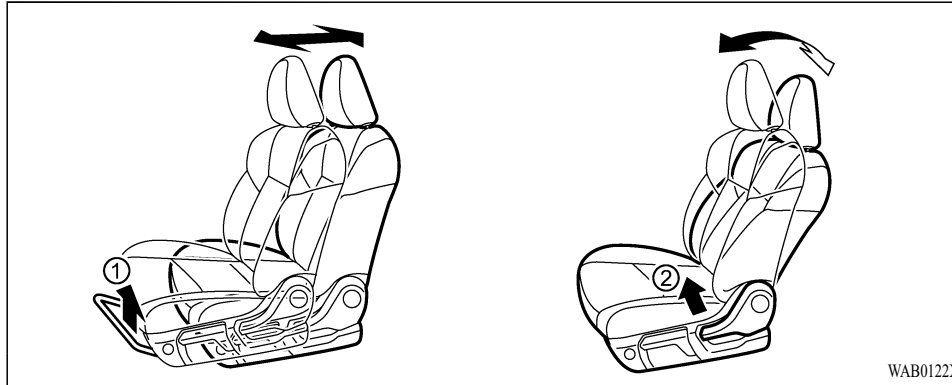

FRONT SEATS

Front manual seat adjustment

Forward and backward:

1. Pull up the adjusting lever ①.
2. Slide the seat to the desired position.
3. Release the adjusting lever to lock the seat in position.

Reclining:

1. Pull up the adjusting lever ②.
2. Tilt the seatback to the desired position.
3. Release the adjusting lever to lock the seatback in position.

The reclining feature allows the adjustment of the seatback for occupants of different sizes to help obtain the proper seat belt fit. (See “Seat belts” (P.1-16).)

The seatback may be reclined to allow occupants to rest when the vehicle is parked.

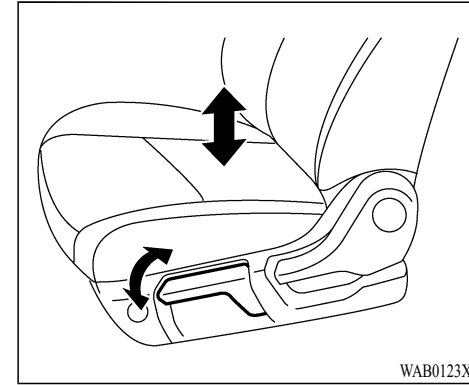

Seat lifter (Driver's seat only):

Pull up or push down the adjusting lever to adjust the seat height until the desired position is achieved.

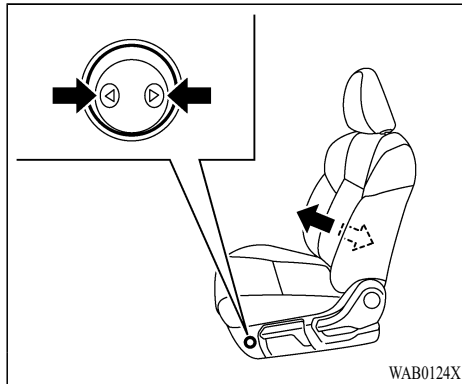

Front power seat adjustment

Operating tips:

- The power seat motor has an auto-reset overload protection circuit. If the motor stops during the seat adjustment, wait 30 seconds, then reactivate the switch.
- To avoid discharge of the battery, do not operate the power seats for a long period of time when the engine is not running.

See “Automatic drive positioner” (P.3-37) for the seat position memory function (if so equipped).

Lumbar support (Driver’s seat only):

The lumbar support feature provides lower back support to the driver.

Push the switch as shown to adjust the seat lumbar area until the desired position is achieved.

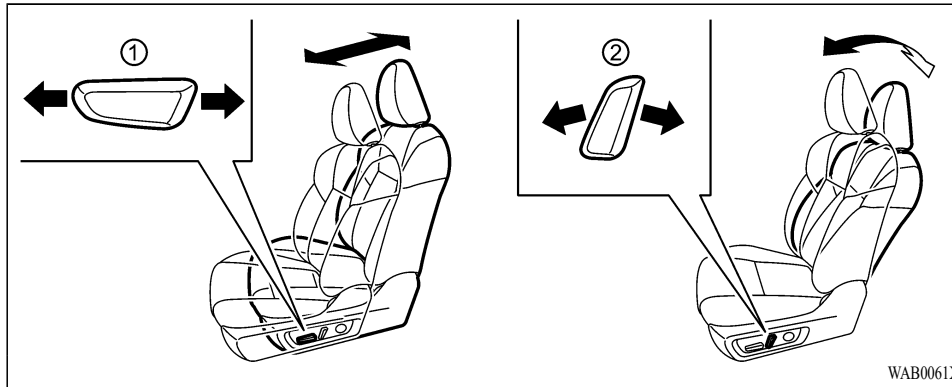

Forward and backward:

Move forward or backward the adjusting switch ① to the desired position.

Reclining:

Move forward or backward the adjusting switch ② to the desired position.

The reclining feature allows the adjustment of the seatback for occupants of different sizes to help obtain the proper seat belt fit. (See “Seat belts” (P.1-16).)

The seatback may be reclined to allow occupants to rest when the vehicle is parked.

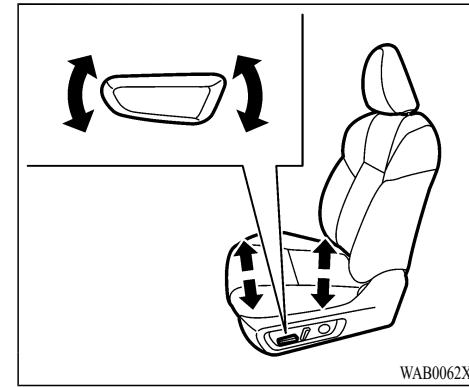

Seat lifter (Driver’s seat only):

Move the switch as shown to adjust the angle of the front portion or height of the seat.

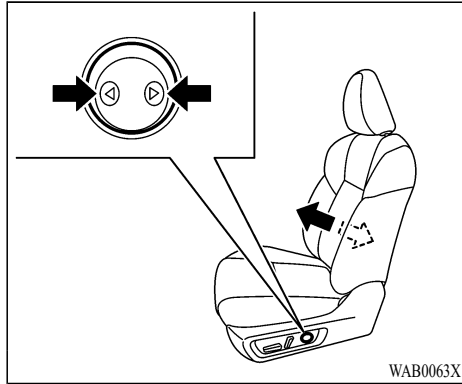

Lumbar support (Driver's seat only):

The lumbar support feature provides lower back support to the driver.

Push the switch as shown to adjust the seat lumbar area until the desired position is achieved.

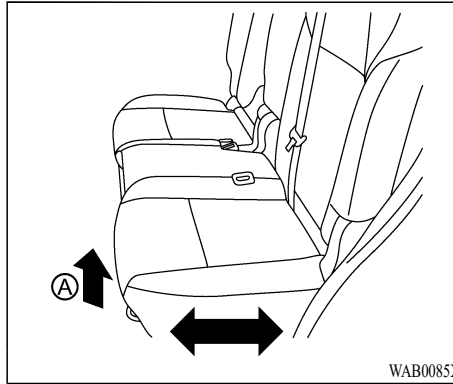

SECOND ROW SEATS

Forward and backward

Pull up the adjusting lever **A** and slide the seat to the desired position. Release the adjusting lever to lock the seat position.

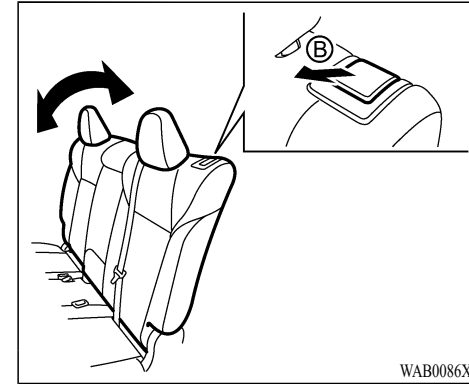

Bench seat

Reclining

Pull the reclining lever **B** and position the seatback at the desired angle. Release the reclining lever after positioning the seat at the desired angle. The center seat is reclined with the left side seat reclining lever.

To return the seatback, pull the lever.

The reclining feature allows adjustment of the seatback for occupants of different sizes to help obtain proper seat belt fit. (See "Precautions on booster seats" (P.1-43).) The seatback may also be reclined to allow occupants to rest when the vehicle is parked.

WARNING

- Do not ride in a moving vehicle when the seatback is reclined. This can be dangerous. The shoulder belt will not be against your body. In an accident, you could be thrown into it and receive neck or other serious injuries. You could also slide under the lap belt and receive serious internal injuries.
- For the most effective protection when the vehicle is in motion, the seat should be upright. Always sit well back and upright in the seat with both feet on the floor and adjust the seat belt properly. See “Precautions on booster seats” (P.1-43).
- After adjustment, check to be sure the seat is securely locked.
- When a person is sitting in the middle seating position of the second row seats, the two sides of the second seats must have the same forward/backward position and the same seatback angle.

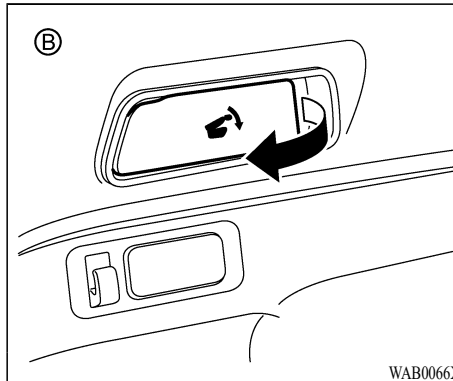
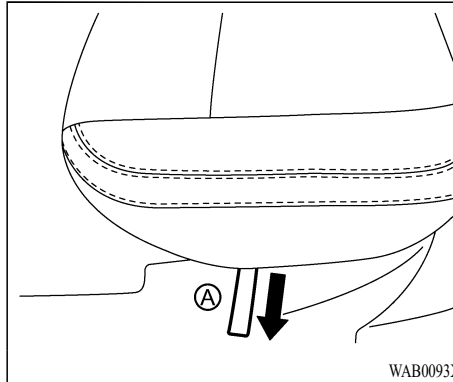

Folding

Before folding the second row seats

- Store the armrest.
- Secure the outer seat belt on the belt hook.
- If the second row seats is equipped with the head restraints, slide the front seat forward and second seat most reward position to make enough room behind the seat so that the second row seatback can be folded flat.
- Remove drink containers from the rear cup holder.
- Lower the center head restraint of the second seat to the lowest position.

To fold down the seatback

Perform either of the following operations to fold down the seatback:

- Pull the strap (A) on the side of the outboard seats.
- Fold the third row seat (see “Third row seats” (P.1-9)) and pull the one-touch second row seat folding lever (B) located on the side of the cargo area.

To return the seatback

To return the second row seatback, pull the strap (A), or fold the third row seat (see “Third row seats” (P.1-9)) and pull the lever (B) and raise the seatback until it latches.

When returning the seatback, make sure that the

seat belt is not interfering with the seatback latch mechanism.

WARNING

- Never allow anyone to ride in the cargo area or on the second row seats when they are in the fold-down position. Use of these areas by passengers without proper restraints could result in serious injury in an accident or sudden stop.
- Do not fold down the second row seats when occupants are in the second row seat area or third row seat, or any cargo is on the second row seats.
- Properly secure all cargo to help prevent it from sliding or shifting. Do not place cargo higher than the seatbacks.
- When returning the seatbacks to the upright position, be certain they are completely secured in the latched position. If they are not completely secured, passengers may be injured in an accident or sudden stop.

Walk-in mechanism

The second row seats can tilt and slide for easy entry/exit to/from the third row seats.

WARNING

After operating the walk-in mechanism, be sure to return the seat to the proper position, taking care of the third row seat passengers, and then tilt up the seatback until it latches.

CAUTION

- Before operating the walk-in mechanism, store the second row seat armrest.
- When operating the walk-in mechanism, push and hold the seatback and operate slowly. If the seatback is tilted down quickly and then allowed to slide, there is a risk that it could contact your face or other parts of your body, or pinch your hand or foot, causing injury.
- When operating the walk-in mechanism, be sure not to contact any moving parts to avoid possible injuries and/or damage.
- When operating the walk-in mechanism, be sure that the second row seats are not occupied by passengers and/or any objects to avoid possible injuries and/or damage.

- Do not operate the walk-in mechanism with objects, drinks, etc. on the seat. This may cause objects to break or cause the passenger room to be soiled.

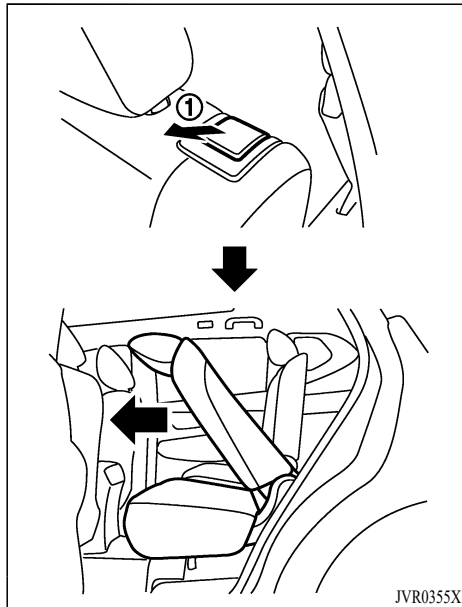

1. Pull the lever ① to tilt down the seatback.
2. Slide the seat forward.
3. When returning the seat to its original position, tilt the seatback up, slide the seat backward where the sufficient space for the third row seat foot area remains, and then secure it in place.

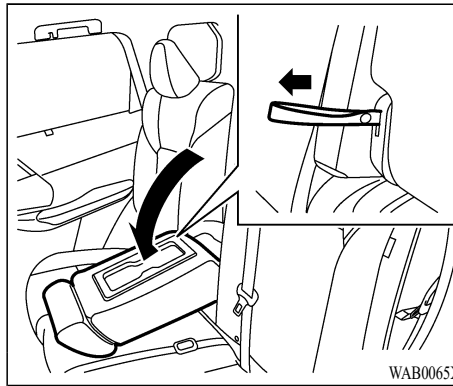

Second row seats

Armrest

Pull the strap and down the armrest as shown.

CAUTION

- Never sit on an armrest. Doing so could damage the armrest.

THIRD ROW SEATS

Seat adjustment

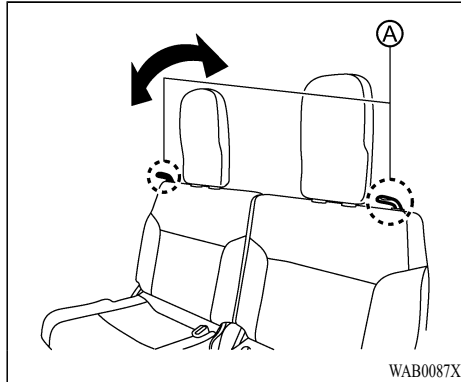

Reclining:

Pull the strap **A** and position the seatback at the desired angle. Release the strap after positioning the seat at the desired angle.

The reclining feature allows adjustment of the seatback for occupants of different sizes to help obtain proper seat belt fit. (See “Precautions on child restraints” (P.1-27).) The seatback may also be reclined to allow occupants to rest when the vehicle is parked.

WARNING

- The third row seats are intended for use by no more than two belted occupants, each of which does not exceed 63 inches (160 cm) in height.

Exceeding these limitations can result in an increased risk of personal injury or death in the event of an accident.

- Do not ride in a moving vehicle when the seatback is reclined. This can be dangerous. The shoulder belt will not be against your body. In an accident, you could be thrown into it and receive neck or other serious injuries. You could also slide under the lap belt and receive serious internal injuries.
- For the most effective protection when the vehicle is in motion, the seat should be upright. Always sit well back and upright in the seat with both feet on the floor and adjust the seat belt properly. See “Precautions on seat belt usage” (P.1-16).
- After adjustment, check to be sure the seat is securely locked.

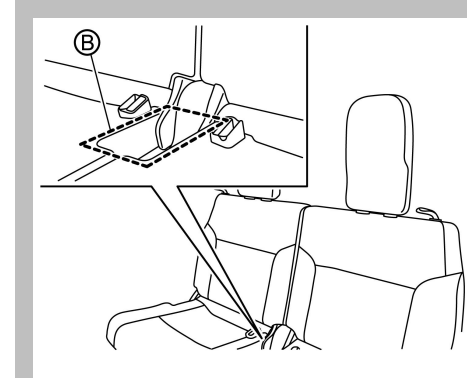

- Do not put your finger in the area between seats **B**. Risk of personal injury.

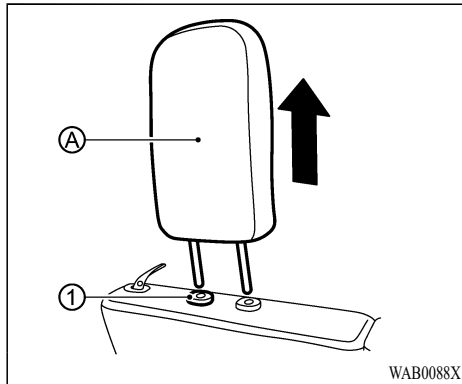

Folding:

Before folding the third row seats, the head restraints of the third row seats must be removed.

Push the lock knob ① and pull the head restraints A off from the seat back.

Also, store the seat belt buckles for the third row seats before folding the seats.

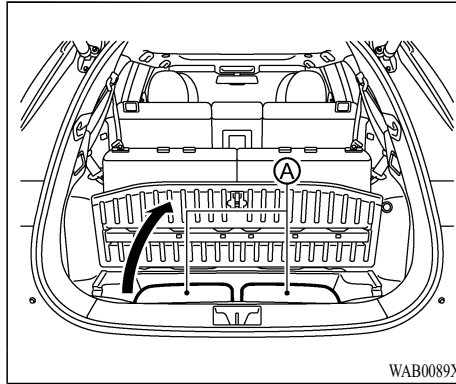

Open the luggage floor board and put the head restraints A in the storage area.

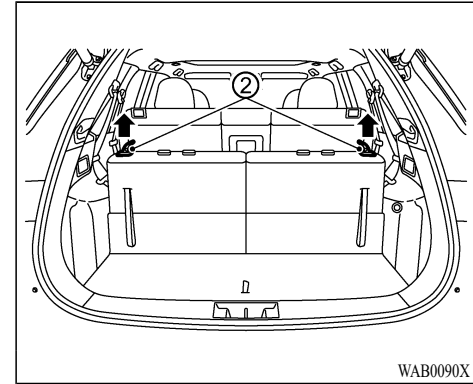

After storing the head restraints, pull the strap ② and fold the seatback.

WARNING

- Never allow anyone to ride in the cargo area or on the third row seat when it is in the fold-down position. Use of these areas by passengers without proper restraints could result in serious injury in an accident or sudden stop.
- Properly secure all cargo with ropes or straps to help prevent it from sliding or shifting. Do not place cargo higher than the seatbacks. In a sudden stop or collision, unsecured cargo could cause personal

HEAD RESTRAINTS

injury.

- When returning the seatbacks to the upright position, be certain they are completely secured in the latched position. If they are not completely secured, passengers may be injured in an accident or sudden stop.

Returning:

1. Pull the strap, then raise the seatback until it locks securely into place. Push lightly on the seatback to confirm that it has actually been secured.
2. Install the head restraints.



WARNING

Head restraints supplement the other vehicle safety systems. They may provide additional protection against injury in certain rear end collisions. Adjustable head restraints must be adjusted properly, as specified in this section. Check the adjustment after someone else uses the seat. Do not attach anything to the head restraint stalks or remove the head restraint. Do not use the seat if the head restraint has been removed. If the head restraint was removed, reinstall and properly adjust the head restraint before an occupant uses the seating position. Failure to follow these instructions can reduce the effectiveness of the head restraint. This may increase the risk of serious injury or death in a collision.

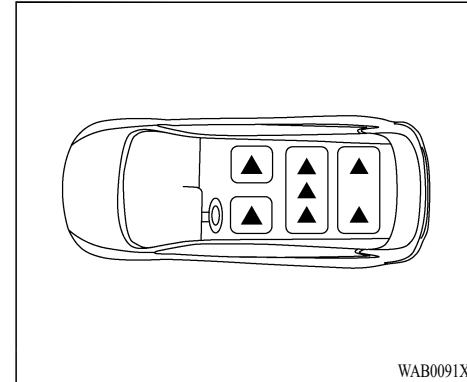

▲ Indicates the seating position is equipped with a head restraint.

- Your vehicle is equipped with a head restraint that may be integrated, adjustable or non-adjustable.
- Adjustable head restraints have multiple notches along the stalk to lock them in a desired adjustment position.
- The non-adjustable head restraints have a single locking notch to secure them to the seat frame.
- The head restraints of the second row seats and third row seats are non-adjustable head restraints.

- Proper Adjustment:
 - For the adjustable type, align the head restraint so the center of your ear is approximately level with the center of the head restraint.
 - If your ear position is still higher than the recommended alignment, place the head restraint at the highest position.
- If the head restraint has been removed, ensure that it is reinstalled and locked in place before riding in that designated seating position.

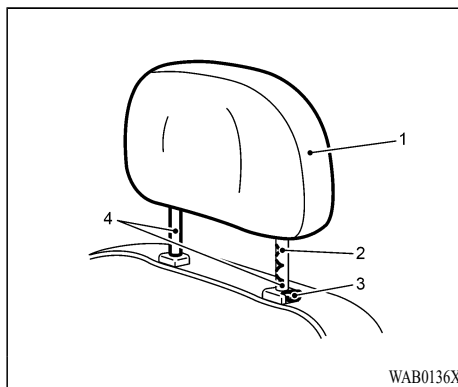

ADJUSTABLE HEAD RESTRAINT COMPONENTS

1. Removable head restraint
2. Multiple notches
3. Lock knob
4. Stalks

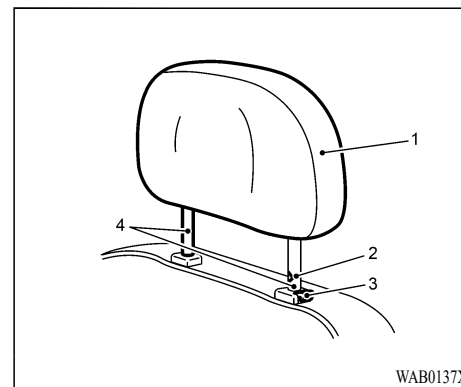

NON-ADJUSTABLE HEAD RESTRAINT COMPONENTS

1. Removable head restraint
2. Single notch
3. Lock knob
4. Stalks

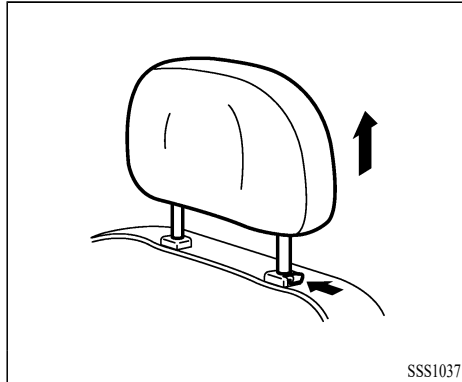

REMOVE

Use the following procedure to remove the head restraint.

1. Pull the head restraint up to the highest position.
2. Push and hold the lock knob.
3. Remove the head restraint from the seat.
4. Store the head restraint properly in a secure place so it is not loose in the vehicle.
5. Reinstall and properly adjust the head restraint before an occupant uses the seating position.

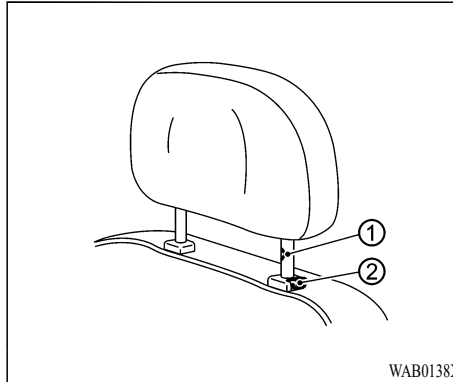

INSTALL

1. Align the head restraint stalks with the holes in the seat. Make sure that the head restraint is facing the correct direction. The stalk with the adjustment notch ① must be installed in the hole with the lock knob ②.
2. Push and hold the lock knob and push the head restraint down.
3. Properly adjust the head restraint before an occupant uses the seating position.

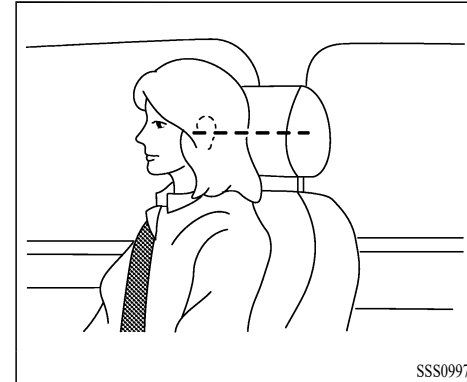

ADJUST

For adjustable head restraint

Adjust the head restraint so the center is level with the center of your ears. If your ear position is still higher than the recommended alignment, place the head restraint at the highest position.

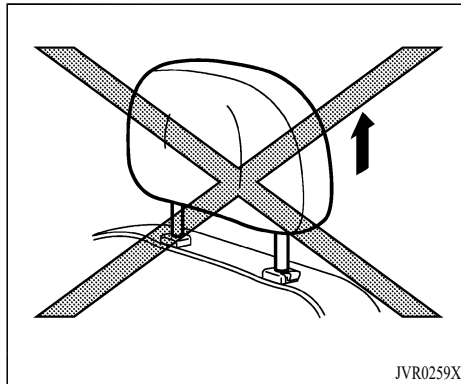

For non-adjustable head restraint

Make sure the head restraint is positioned so the lock knob is engaged in the notch before riding in that designated seating position.

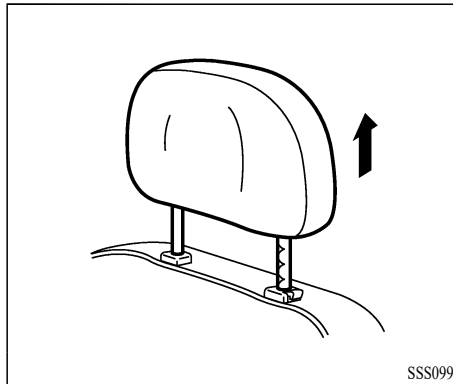

Raise

To raise the head restraint, pull it up.
Make sure the head restraint is positioned so the lock knob is engaged in the notch before riding in that designated seating position.

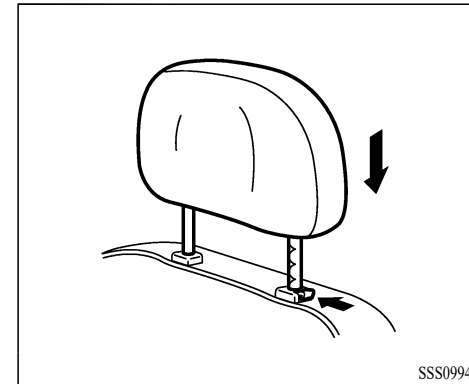

Lower

To lower, push and hold the lock knob and push the head restraint down.
Make sure the head restraint is positioned so the lock knob is engaged in the notch before riding in that designated seating position.

SEAT BELTS

PRECAUTIONS ON SEAT BELT USAGE

If you are wearing your seat belt properly adjusted, and you are sitting upright and well back in your seat with both feet on the floor, your chances of being injured or killed in an accident and/or the severity of injury may be greatly reduced. Mitsubishi Motors strongly encourages you and all of your passengers to buckle up every time you drive, even if your seating position includes a airbag.

Most U.S. states and Canadian provinces or territories specify that seat belts be worn at all times when a vehicle is being driven.

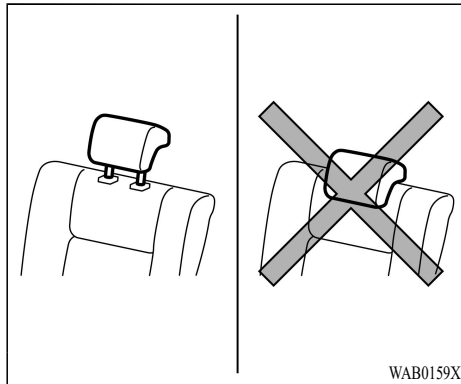

WARNING

When a person sits in the second center seating position, pull up the head restraint to a height at which it locks in position. Be sure to make this adjustment before starting to drive. Serious injuries could otherwise be suffered in the result of an impact.

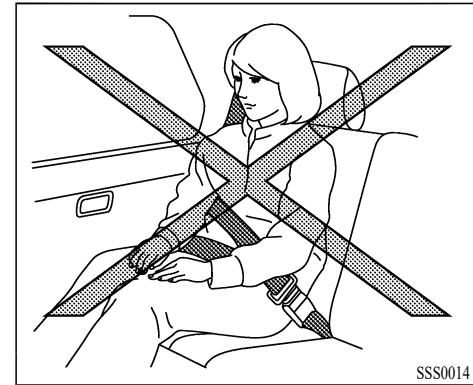
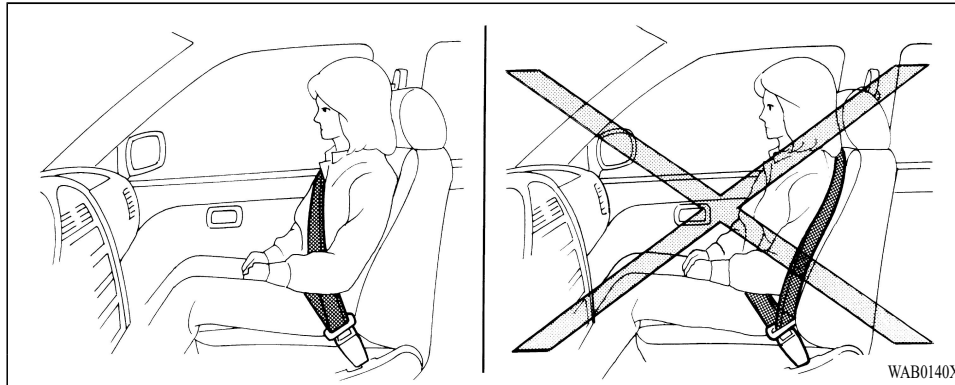
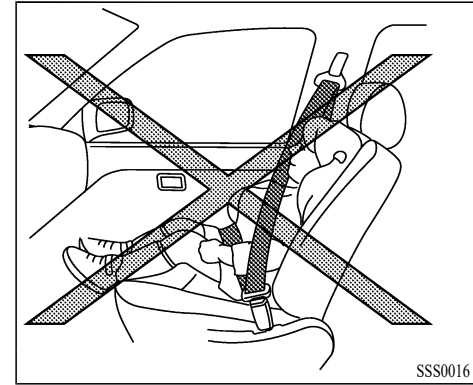
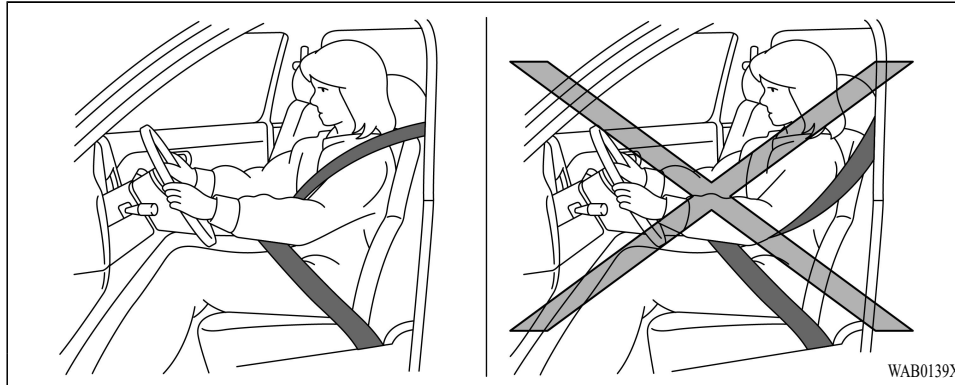

WARNING

- Every person who drives or rides in this vehicle should use a seat belt at all times. Children should be properly restrained in the rear seat whenever possible. If one must be used in the front passenger seat, move the seat to the most rearward position and make sure the child stays in the child restraint system, properly restrained. Failure to follow these instructions could result in serious injury or death to the child.
- The seat belt should be properly adjusted to a snug fit. Failure to do so may reduce the effectiveness of the entire restraint system and increase the chance or severity of injury in an accident. Serious injury or death can occur if the seat belt is not worn properly.
- Always route the shoulder belt over your shoulder and across your chest. Never put the belt behind your back, under your arm or across your neck. The belt should be away from your face and neck, but not falling off your shoulder.
- Position the lap belt as low and snug as possible **AROUND THE HIPS, NOT THE WAIST**. A lap belt worn too high could increase the risk of internal injuries in an accident.

- Be sure the seat belt tongue is securely fastened to the proper buckle.
- Do not wear the seat belt inside out or twisted. Doing so may reduce its effectiveness.
- Do not allow more than one person to use the same seat belt.
- Never carry more people in the vehicle than there are seat belts.
- If the seat belt warning light glows continuously while the ignition is turned ON with all doors closed and all seat belts fastened, it may indicate a malfunction in the system. Have the system checked. It is recommended you visit an authorized Mitsubishi Motors dealer for this service.
- No changes should be made to the seat belt system. For example, do not modify the seat belt, add material, or install devices that may change the seat belt routing or tension. Doing so may affect the operation of the seat belt system. Modifying or tampering with the seat belt system may result in serious personal injury.

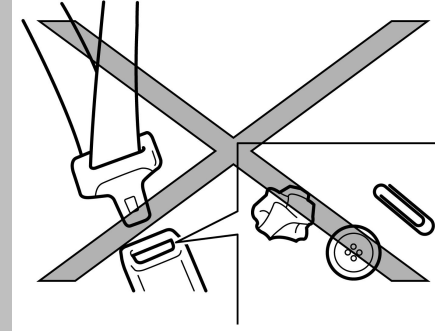

- Never insert any foreign object, such as a piece of plastic, paper clip, button or coin, into the seat belt buckle.
- Once a seat belt pretensioner has activated, it cannot be reused and must be replaced together with the retractor. It is recommended you visit an authorized Mitsubishi Motors dealer for this service.
- All seat belt assemblies, including retractors and attaching hardware, should be inspected after any collision. It is recommended you visit an authorized Mitsubishi Motors dealer for this service. Mitsubishi Motors recommends that all seat belt assemblies in use during a collision be replaced unless the collision was minor and the belts show no damage and continue to operate properly. Seat belt assemblies not

in use during a collision should also be inspected and replaced if either damage or improper operation is noted.

- All child restraints and attaching hardware should be inspected after any collision. Always follow the restraint manufacturer's inspection instructions and replacement recommendations. The child restraints should be replaced if they are damaged.



SEAT BELT WARNING LIGHT AND CHIME

The driver and front passenger seats are equipped with an enhanced seat belt reminder function. A visual and audible alert will operate if a driver or front passenger seat belt is unbuckled at speeds of approximately 10 MPH (15 km/h) or more under the following conditions:

- If the driver seat belt is not fastened.
- The front passenger's seat belt is not fastened and the seat is occupied by a passenger for 7 seconds after the ignition switch is placed in the ON position.

- The front passenger's seat belt is not fastened and objects or external force on the passenger seat change the seat belt reminder classification to "occupied".

The seat belt warning light will flash under the conditions shown above until the necessary seat belt is securely fastened.

A warning chime will sound for approximately 95 seconds or until one of the following conditions is met:

- The unbuckled front passenger's seat belt is securely fastened.
- The seat belt reminder function in the front passenger seat no longer detects that the front passenger seat is occupied.
- The ignition switch is turned off.

The below situations could result in the seat belt warning light being illuminated and the chime sounding, even with no occupant present in the passenger seat:

- Heavy objects placed on the seat.
- Someone pushing or pulling on the front passenger seat.
- An object placed under the front passenger seat.
- An object placed between the seat cushion and center console or between the seat cushion and the door.

- An object hanging on the seat or placed in any of seatback pocket.
- A child restraint or other object pressing against the rear of the seatback.

The rear seats are equipped with a seat belt warning in the multi-information display. (See “10. Rear seat belt warning” (P.2-34).)

PREGNANT WOMEN

Mitsubishi Motors recommends that pregnant women use seat belts. The seat belt should be worn snug, and always position the lap belt as low as possible around the hips, not the waist. Place the shoulder belt over your shoulder and across your chest. Never put the lap/shoulder belt over your abdominal area. Contact your doctor for specific recommendations.

INJURED PERSONS

Mitsubishi Motors recommends that injured persons use seat belts, depending on the injury. Check with your doctor for specific recommendations.

THREE-POINT TYPE SEAT BELT WITH RETRACTOR

WARNING

- Every person who drives or rides in this vehicle should use a seat belt at all times. Children should be in the rear seats and in an appropriate restraint.
- Do not ride in a moving vehicle when the seatback is reclined. This can be dangerous. The shoulder belt will not be against your body. In an accident, you could be thrown into it and receive neck or other serious injuries. You could also slide under the lap belt and receive serious internal injuries.
- For the most effective protection when the vehicle is in motion, the seat should be upright. Always sit well back and upright in the seat with both feet on the floor and adjust the seat belt properly.
- Do not allow children to play with the seat belts. Most seating positions are equipped with Automatic Locking Retractor (ALR) mode seat belts. If the seat belt becomes wrapped around a child's neck with the ALR mode activated, the child can be seriously injured or killed if the seat belt retracts and becomes tight. This can occur even if the vehicle is parked. Unbuckle the

seat belt to release the child. If the seat belt cannot be unbuckled or is already unbuckled, release the child by cutting the seat belt with a suitable tool (such as a knife or scissors) to release the seat belt.

Fastening the seat belts

1. Adjust the seat. (See “Seats” (P.1-2).)



2. Slowly pull the seat belt out of the retractor and insert the tongue into the buckle **A** until you hear and feel the latch engage.
 - **The retractor is designed to lock during a sudden stop or on impact. A slow pulling motion permits the belt to move and allows you some freedom of movement in the seat.**
 - **If the seat belt cannot be pulled from its fully retracted position, firmly pull the belt and release it. Then smoothly pull the belt out of the retractor.**

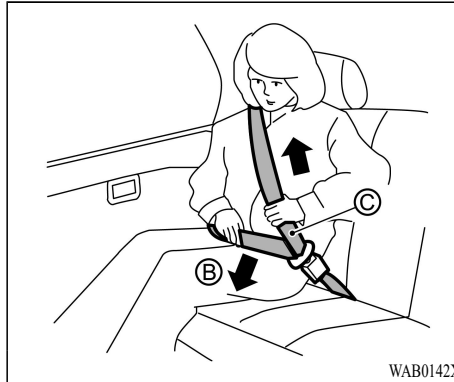

3. Position the lap belt portion **low and snug on the hips** **B** as shown.
4. Pull the shoulder belt portion toward the retractor to take up extra slack **C**. Be sure the shoulder belt is routed over your shoulder and across your chest.

The three-point seat belts in the front passenger seat and the rear seating positions have two modes of operation:

- Emergency Locking Retractor (ELR)
- Automatic Locking Retractor (ALR)

The Emergency Locking Retractor (ELR) mode allows the seat belt to extend and retract to allow the driver and passengers some freedom of movement in the seat. The ELR locks the

seat belt when the vehicle slows down rapidly or during certain impacts.

The Automatic Locking Retractor (ALR) mode (child restraint mode) locks the seat belt for child restraint installation.

When ALR mode is activated the seat belt cannot be extended again until the seat belt tongue is detached from the buckle and fully retracted. The seat belt returns to the ELR mode after the seat belt fully retracts. For additional information, see “Child restraints” (P.1-27).

The ALR mode should be used only for child restraint installation. During normal seat belt use by an occupant, the ALR mode should not be activated. If it is activated, it may cause uncomfortable seat belt tension.

WARNING

When fastening the seat belts, be certain that seatbacks are completely secured in the latched position. If they are not completely secured, passengers may be injured in an accident or sudden stop.

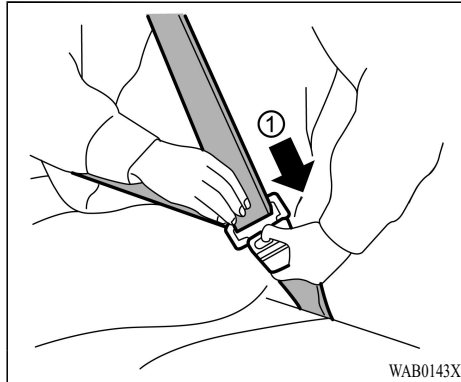

Unfastening the seat belts

To unfasten the seat belt, push the button on the buckle ①. The seat belt automatically retracts.

Checking seat belt operation

Seat belt retractors are designed to lock seat belt movement by two separate methods:

- When the belt is pulled quickly from the retractor.
- When the vehicle slows down rapidly.

To increase your confidence in the seat belts, check the operation as follows:

- Grasp the shoulder belt and pull forward quickly. The retractor should lock and

restrict further belt movement.

If the retractor does not lock during this check, get the system checked. It is recommended you visit an authorized Mitsubishi Motors dealer for this service, or to learn more about seat belt operation.

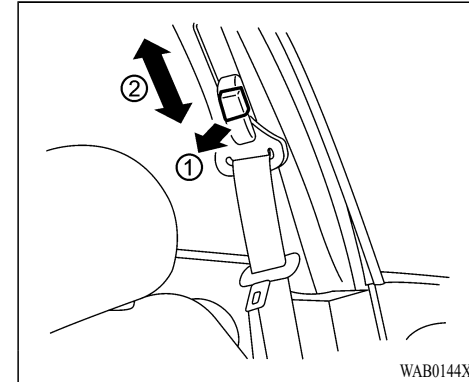

Shoulder belt height adjustment (for front seats)

The shoulder belt anchor height should be adjusted to the position best for you. (See “Precautions on seat belt usage” (P.1-16).)

To adjust, pull the adjustment button ①, and then move the shoulder belt anchor to the desired position ②, so that the belt passes over the center of the shoulder. The belt should be away from your face and neck, but not falling off of your shoulder. Release the adjustment button to lock the shoulder belt anchor into position.

The range of height adjustment of the shoulder belt may vary depending on the model.

WARNING

- After adjustment, release the adjustment button and try to move the shoulder belt anchor up and down to make sure it is securely fixed in position.
- The shoulder belt anchor height should be adjusted to the position best for you. Failure to do so may reduce the effectiveness of the entire restraint system and increase the chance or severity of injury in an accident.

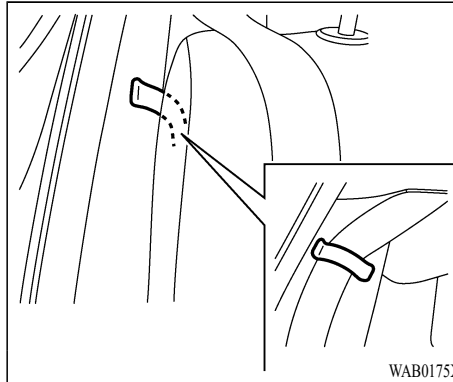

Example

Seat belt clip

When the seat belt is not in use and when folding down the second row or third row seats, clip the second row or third row outer seat belts on the seat belt clips.

Be sure not to clip the seat belt tongue to the clip.

WARNING

Before folding up the second row or third row seats, ensure the seat belts are not obstructing the seatback latches to avoid damage to the seat belt webbing.

SEAT BELT EXTENDERS

If your seat belt, even when fully extended, is not long enough, a seat belt extender must be obtained. The extender may be used for either of the front seats.

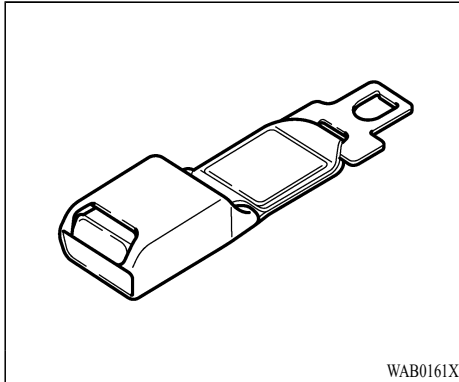

WAB0161X

WARNING

- The extender should only be used if the existing belt is not long enough. Anyone who can use the standard seat belt should not use an extender. Unnecessary use of an extender can adversely affect seat belt performance in an accident.
- When not required, the extender must be removed and stowed.
- Never use seat belt extenders to install child restraints. If the child restraint is not secured properly, the child could be seriously injured or killed in a collision or a sudden stop.

SEAT BELT MAINTENANCE

- To clean the seat belt webbing, apply a mild soap solution or any solution recommended for cleaning upholstery or carpets. Then wipe with a cloth and allow the seat belts to dry in the shade. Do not allow the seat belts to retract until they are completely dry.
- If dirt builds up in the shoulder belt guide of the seat belt anchors, the seat belts may retract slowly. Wipe the shoulder belt guide with a clean, dry cloth.
- Periodically check to see that the seat belt and the metal components, such as buckles, tongues, retractors, flexible wires and anchors, work properly. If loose parts, deterioration, cuts or other damage on the webbing is found, the entire seat belt assembly should be replaced.

CHILD SAFETY

WARNING

Do not allow children to play with the seat belts. Most seating positions are equipped with Automatic Locking Retractor (ALR) mode seat belts. If the seat belt becomes wrapped around a child's neck with the ALR mode activated, the child can be seriously injured or killed if the seat belt retracts and becomes tight. This can occur even if the vehicle is parked. Unbuckle the seat belt to release the child. If the seat belt cannot be unbuckled or is already unbuckled, release the child by cutting the seat belt with a suitable tool (such as a knife or scissors) to release the seat belt.

Children need adults to help protect them. They need to be properly restrained.

In addition to the general information in this manual, child safety information is available from many other sources, including doctors, teachers, government traffic safety offices, and community organizations. Every child is different, so be sure to learn the best way to transport your child.

There are three basic types of child restraint systems:

- Rear-facing child restraint

- Forward-facing child restraint
- Booster seat

The proper restraint depends on the child's size. Generally, infants up to about 1 year and less than 20 lb (9 kg) should be placed in rear-facing child restraints. Forward-facing child restraints are available for children who outgrow rear-facing child restraints and are at least 1 year old. Booster seats are used to help position a vehicle lap/shoulder belt on a child who can no longer use a forward-facing child restraint.

WARNING

Infants and children need special protection. The vehicle's seat belts may not fit them properly. The shoulder belt may come too close to the face or neck. The lap belt may not fit over their small hip bones. In an accident, an improperly fitting seat belt could cause serious or fatal injury. Always use appropriate child restraints.

All U.S. states and Canadian provinces or territories require the use of approved child restraints for infants and small children. See "Child restraints" (P.1-27).

A child restraint may be secured in the vehicle by using either the LATCH (Lower Anchors and Tethers for CHildren) system or with the

vehicle seat belt. See "Child restraints" (P.1-27) for more information.

Mitsubishi Motors recommends that all pre-teens and children be restrained in the rear seat. Studies show that children are safer when properly restrained in the rear seat than in the front seat.

This is especially important because your vehicle has a supplemental restraint system (Airbag system) for the front passenger. See "Supplemental Restraint System (SRS)" (P.1-47).

INFANTS

Infants up to at least 1 year old should be placed in a rear-facing child restraint. Mitsubishi Motors recommends that infants be placed in child restraints that comply with Federal Motor Vehicle Safety Standards or Canadian Motor Vehicle Safety Standards. You should choose a child restraint that fits your vehicle and always follow the manufacturer's instructions for installation and use.

SMALL CHILDREN

Children that are over 1 year old and weigh at least 20 lb (9 kg) should remain in a rear-facing child restraint as long as possible up to the height or weight limit of the child restraint. Children who outgrow the height or weight limit of the rear-facing child restraint and are at

least 1 year old should be secured in a forward-facing child restraint with a harness. Refer to the manufacturer's instructions for minimum and maximum weight and height recommendations. Mitsubishi Motors recommends that small children be placed in child restraints that comply with Federal Motor Vehicle Safety Standards or Canadian Motor Vehicle Safety Standards. You should choose a child restraint that fits your vehicle and always follow the manufacturer's instructions for installation and use.

LARGER CHILDREN

Children should remain in a forward-facing child restraint with a harness until they reach the maximum height or weight limit allowed by the child restraint manufacturer.

Once a child outgrows the height or weight limit of the harness-equipped forward-facing child restraint, Mitsubishi Motors recommends that the child be placed in a commercially available booster seat to obtain proper seat belt fit. For a seat belt to fit properly, the booster seat should raise the child so that the shoulder belt is properly positioned across the chest and the top, middle portion of the shoulder. The shoulder belt should not cross the neck or face and should not fall off the shoulder. The lap belt should lie snugly across the lower hips or upper thighs, not the abdomen.

A booster seat can only be used in seating positions that have a three-point type seat belt. The booster seat should fit the vehicle seat and have a label certifying that it complies with Federal Motor Vehicle Safety Standards or Canadian Motor Vehicle Safety Standards.

A booster seat should be used until the child can pass the seat belt fit test below:

- Are the child's back and hips against the vehicle seatback?
- Is the child able to sit without slouching?
- Do the child's knees bend easily over the front edge of the seat with feet flat on the floor?
- Can the child safely wear the seat belt (lap belt low and snug across the hips and shoulder belt across mid-chest and shoulder)?
- Is the child able to use the properly adjusted head restraint?
- Will the child be able to stay in position for the entire ride?



If you answered no to any of these questions, the child should remain in a booster seat using a three-point type seat belt.

NOTE:

Laws in some communities may follow different guidelines. Check local and state regulations to confirm your child is using the correct restraint system before traveling.

WARNING

Never let a child stand or kneel on any seat and do not allow a child in the cargo area. The child could be seriously injured or killed in a sudden stop or collision.

CHILD RESTRAINTS

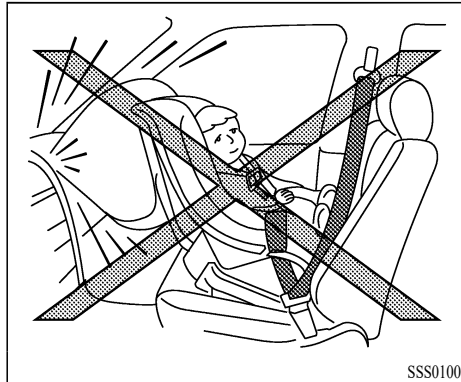
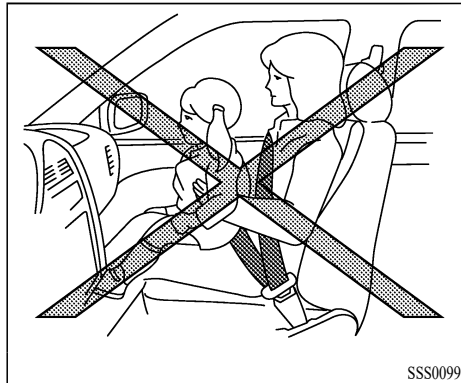

PRECAUTIONS ON CHILD RESTRAINTS

WARNING

- Failure to follow the warnings and instructions for proper use and installation of child restraints could result in serious injury or death of a child or other passengers in a sudden stop or collision:
 - The child restraint must be used and installed properly. Always follow all of the child restraint manufacturer's instructions for installation and use.
 - Infants and children should never be held on anyone's lap. Even the strongest adult cannot resist the forces of a collision.
 - Do not put a seat belt around both a child and another passenger.
 - Mitsubishi Motors recommends that all child restraints be installed in the rear seat. Studies show that children are safer when properly restrained in the rear seat than in the front seat. If you must install a forward-facing

child restraint in the front seat, see “Forward-facing child restraint installation using the seat belts” (P.1-39).

- Even with the Advanced Airbag System, never install a rear-facing child restraint or infant restraint in the front seat. An inflating airbag could seriously injure or kill a child. A rear-facing child restraint or infant restraint must only be used in the rear seat.
- Be sure to purchase a child restraint that will fit the child and vehicle. Some child restraints may not fit properly in your vehicle.
- Child restraint anchorages are designed to withstand only those loads imposed by correctly fitted child restraints. Under no circumstances are they to be used to attach adult seat belts, or other items or equipment to the vehicle. Doing so could damage the child restraint anchorages. The child restraint will not be properly installed using the damaged anchorage, and a child could be

seriously injured or killed in a collision.

- **Never use the anchor points for adult seat belts or harnesses.**
- **A child restraint with a top tether strap should not be used in the front passenger seat.**
- **Infants and children should always be placed in an appropriate child restraint while in the vehicle.**
- **When the child restraint is not in use, keep it secured with the LATCH system or a seat belt. In a sudden stop or collision, loose objects can injure occupants or damage the vehicle.**

CAUTION

A child restraint in a closed vehicle can become very hot. Check the seating surface and buckles before placing a child in the child restraint.

This vehicle is equipped with a universal child restraint anchor system, referred to as the LATCH (Lower Anchors and Tethers for Children) system. Some child restraints include rigid or webbing-mounted attachments that can

be connected to these anchors.

For details, see “Lower Anchors and Tethers for Children (LATCH) system” (P.1-29).

If you do not have a LATCH compatible child restraint, the vehicle seat belts can be used.

Several manufacturers offer child restraints for infants and small children of various sizes. When selecting any child restraint, keep the following points in mind:

- Choose only a restraint with a label certifying that it complies with Federal Motor Vehicle Safety Standard 213 or Motor Vehicle Restraint Systems and Booster Seats Safety Regulations (RSSR).
- Check the child restraint in your vehicle to be sure it is compatible with the vehicle’s seat and seat belt system.
- If the child restraint is compatible with your vehicle, place your child in the child restraint and check the various adjustments to be sure the child restraint is compatible with your child. Choose a child restraint that is designed for your child’s height and weight. Always follow all recommended procedures.
- If the combined weight of the child and child restraint is less than 65 lb (29.5 kg), you may use either the LATCH anchors or the seat belt to install the child restraint (not both at the same time).

- If the combined weight of the child and child restraint is greater than 65 lb (29.5 kg), use the vehicle’s seat belt (not the lower anchors) to install the child restraint.
- Be sure to follow the child restraint manufacturer’s instructions for installation.

All U.S. states and Canadian provinces or territories require that infants and small children be restrained in an approved child restraint at all times while the vehicle is being operated. Canadian law requires the top tether strap on forward-facing child restraints be secured to the designated anchor point on the vehicle.

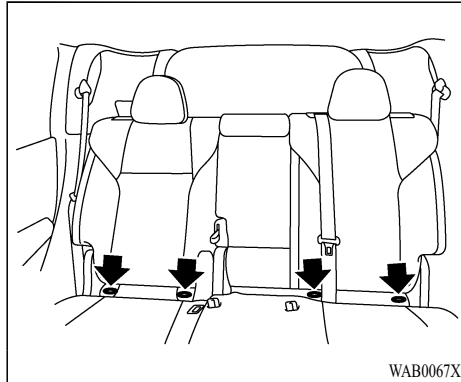

LATCH system anchor location

Lower Anchors and Tethers for Children (LATCH) SYSTEM

Your vehicle is equipped with special anchor points that are used with LATCH system compatible child restraints. This system may also be referred to as the ISOFIX or ISOFIX compatible system. With this system, you do not have to use a vehicle seat belt to secure the child restraint unless the combined weight of the child and child restraint exceeds 65 lb (29.5 kg). If the combined weight of the child and child restraint is greater than 65 lb (29.5 kg), use the vehicle's seat belt (not the lower anchors) to install the child restraint. Be sure

to follow the child restraint manufacturer's instructions for installation.

LATCH lower anchor

WARNING

Failure to follow the warnings and instructions for proper use and installation of child restraints could result in serious injury or death of a child or other passengers in a sudden stop or collision:

- Attach LATCH system compatible child restraints only at the locations shown in the illustration.
- Do not secure a child restraint in the center rear seating position using the LATCH lower anchors. The child restraint will not be secured properly.
- Inspect the lower anchors by inserting your fingers into the lower anchor area. Feel to make sure there are no obstructions over the anchors such as seat belt webbing or seat cushion material. The child restraint will not be secured properly if the lower anchors are obstructed.
- Child restraint anchorages are designed to withstand only those loads imposed by correctly fitted child restraints. Under no circumstances are they to be used to attach adult seat belts, or other items or equipment to the vehicle. Doing so could damage

the child restraint anchorages. The child restraint will not be properly installed using the damaged anchorage, and a child could be seriously injured or killed in a collision.

LATCH lower anchor location

The LATCH lower anchor points are provided to install child restraints in the second row outboard seating positions only. **Do not attempt to install a child restraint in the center seating position using the LATCH lower anchors.**

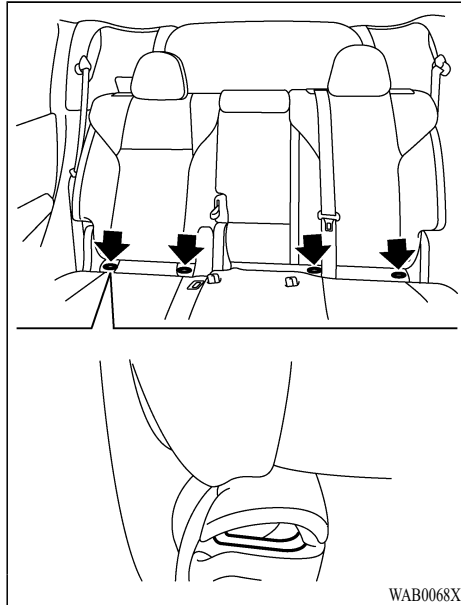

The LATCH lower anchor points are located at the second row seat cushions.

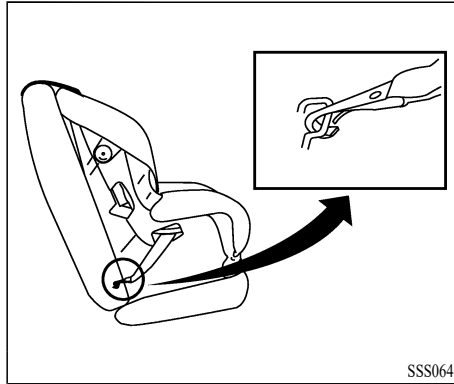

LATCH webbing-mounted attachment

Installing child restraint LATCH lower anchor attachments

LATCH compatible child restraints include two rigid or webbing-mounted attachments that can be connected to two anchors located at certain seating positions in your vehicle. With this system, you do not have to use a vehicle seat belt to secure the child restraint. Check your child restraint for a label stating that it is compatible with LATCH. This information may also be in the instructions provided by the child restraint manufacturer.

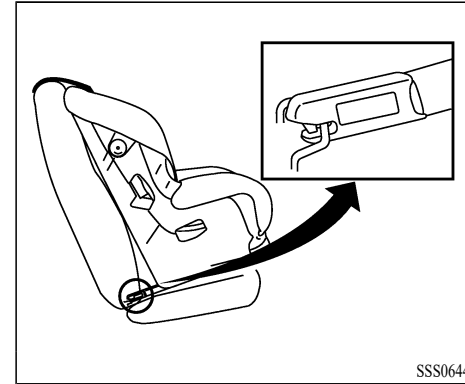

LATCH rigid attachment

When installing a child restraint, carefully read and follow the instructions in this manual and those supplied with the child restraint.

Top tether anchor

! WARNING

Properly secure cargo and do not allow it to contact the top tether strap when it is attached to the top tether anchor. Cargo that is not properly secured or cargo that contacts the top tether strap may damage the top tether strap during a collision. If the tonneau cover (if so equipped) contacts the top tether strap when it is attached to the top tether anchor, remove the

tonneau cover from the vehicle. If the tonneau cover is not removed, it may damage the top tether strap during a collision. Your child could be seriously injured or killed in a collision if the child restraint top tether strap is damaged.

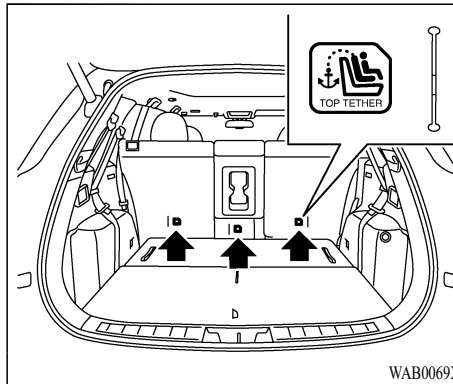

Top tether anchor point locations

WARNING

Child restraint anchorages are designed to withstand only those loads imposed by correctly fitted child restraints. Under no circumstances are they to be used to attach adult seat belts, or other items or equipment to the vehicle. Doing so could damage the child restraint anchorages. The child restraint will not be properly installed using the damaged anchorage, and a child could be seriously injured or killed in a collision.

Anchor points are located on the back side of

the seatbacks.

If a child restraint has a top tether strap, it must be used when installing with the LATCH lower anchor attachments or seat belts.

If you have any questions when installing a top tether strap child restraint on the rear seat, it is recommended you visit an authorized Mitsubishi Motors dealer for this service.

REAR-FACING CHILD RESTRAINT INSTALLATION USING LATCH

Refer to all Warnings and Cautions in the “Child safety” and “Child restraints” sections before installing a child restraint.

Do not use the lower anchors if the combined weight of the child and the child restraint exceeds 65 lb (29.5 kg). If the combined weight of the child and the child restraint is greater than 65 lb (29.5 kg), use the vehicle’s seat belt (not the lower anchors) to install the child restraint. Be sure to follow the child restraint manufacturer’s instructions for installation.

Follow these steps to install a rear-facing child restraint using the LATCH system:

1. Position the child restraint on the seat. Always follow the child restraint manufacturer’s instructions.

- Adjust the seat where the child restraint system will be installed to the most rearward position.

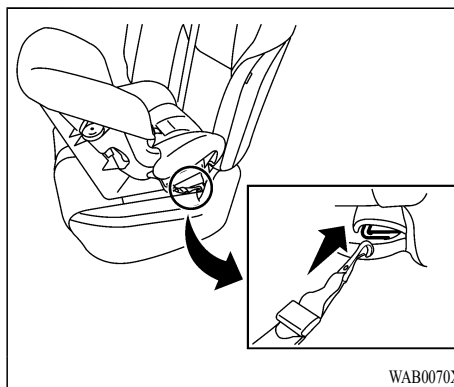

Rear-facing web-mounted — step 2

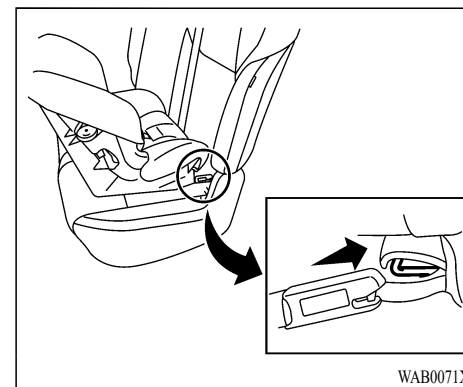

Rear-facing rigid-mounted — step 2

- Secure the child restraint anchor attachments to the LATCH lower anchors. Check to make sure the LATCH attachment is properly attached to the lower anchors. Do not attach the child restraint on the second row center seat.

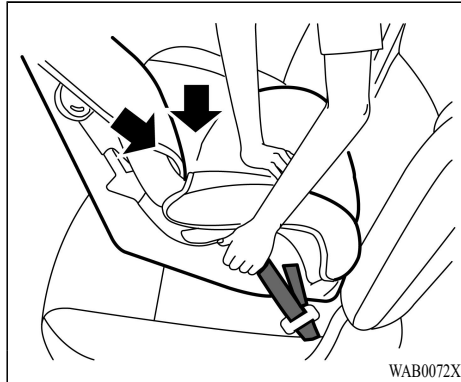

Rear-facing — step 3

3. For child restraints that are equipped with webbing-mounted attachments, remove any additional slack from the anchor attachments. Press downward and rearward firmly in the center of the child restraint with your hand to compress the vehicle seat cushion and seatback while tightening the webbing of the anchor attachments.

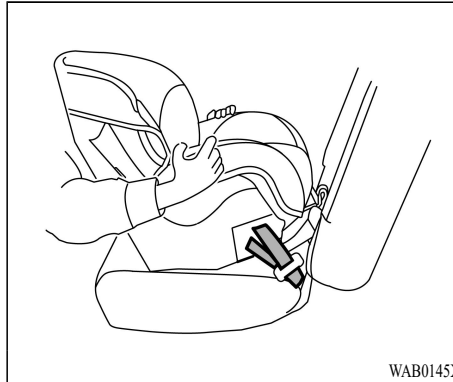

Rear-facing — step 4

4. After attaching the child restraint, test it before you place the child in it. Push it from side to side while holding the child restraint near the LATCH attachment path. The child restraint should not move more than 1 inch (25 mm), from side to side. Try to tug it forward and check to see if the LATCH attachment holds the restraint in place. If the restraint is not secure, tighten the LATCH attachment as necessary, or put the restraint in another seat and test it again. You may need to try a different child restraint or try installing by using the vehicle seat belt (if applicable). Not all child restraints fit in all types of vehicles.

5. Check to make sure the child restraint is properly secured prior to each use. If the child restraint is loose, repeat steps 1 through 4.

REAR-FACING CHILD RESTRAINT INSTALLATION USING THE SEAT BELTS

WARNING

The three-point seat belt with Automatic Locking Retractor (ALR) must be used when installing a child restraint. Failure to use the ALR mode will result in the child restraint not being properly secured. The restraint could tip over or be loose and cause injury to a child in a sudden stop or collision.

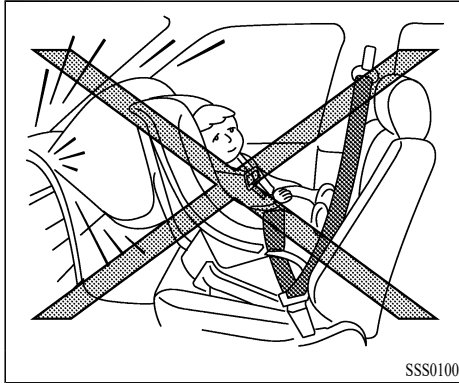

Rear-facing — step 1

Refer to all Warnings and Cautions in the “Child safety” (P.1-24) and “Child restraints” (P.1-27) before installing a child restraint.

Do not use the lower anchors if the combined weight of the child and the child restraint exceeds 65 lb (29.5 kg). If the combined weight of the child and the child restraint is greater than 65 lb (29.5 kg), use the vehicle’s seat belt (not the lower anchors) to install the child restraint. Be sure to follow the child restraint manufacturer’s instructions for installation.

Follow these steps to install a rear-facing child restraint using the vehicle seat belts in the second row seats and third row seats:

1. **Child restraints for infants must be used in the rear-facing direction and therefore must not be used in the front seat.** Position the child restraint on the seat. Always follow the restraint manufacturer’s instructions.
 - Adjust the seat where the child restraint system will be installed to the most rearward position.

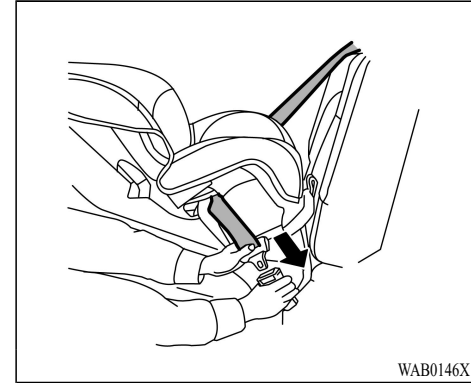

Rear-facing — step 2

2. Route the seat belt tongue through the child restraint and insert it into the buckle until you hear and feel the latch engage. Be sure to follow the child restraint manufacturer’s instructions for belt routing.

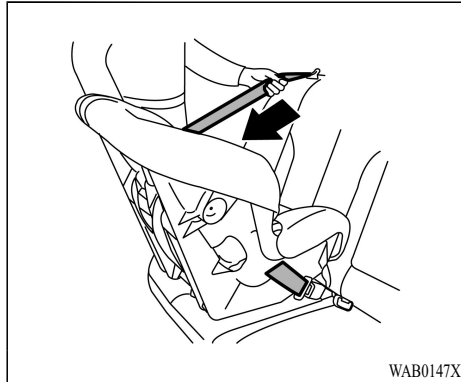
**Rear-facing — step 3**

3. Pull the shoulder belt until the belt is fully extended. At this time, the seat belt retractor is in the Automatic Locking Retractor (ALR) mode (child restraint mode). It reverts to the Emergency Locking Retractor (ELR) mode when the seat belt is fully retracted.

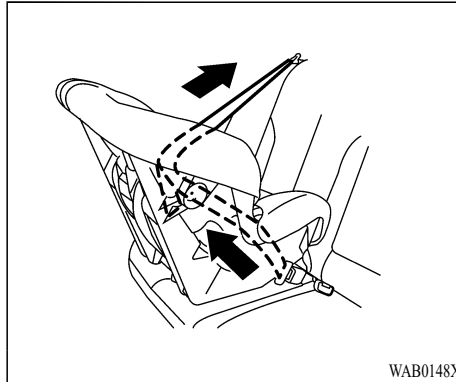
**Rear-facing — step 4**

4. Allow the seat belt to retract. Pull up on the shoulder belt to remove any slack in the belt.

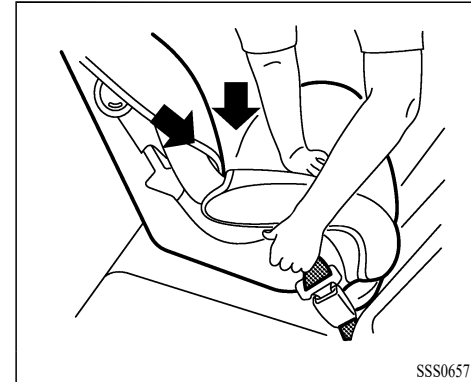
**Rear-facing — step 5**

5. Remove any additional slack from the seat belt; press downward and rearward firmly in the center of the child restraint to compress the vehicle seat cushion and seatback while pulling up on the seat belt.

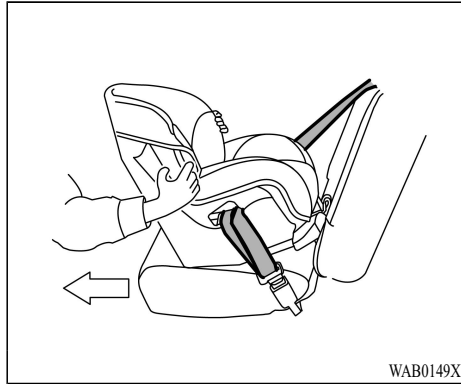

Rear-facing — step 6

6. After attaching the child restraint, test it before you place the child in it. Push it from side to side while holding the child restraint near the seat belt path. The child restraint should not move more than 1 inch (25 mm), from side to side. Try to tug it forward and check to see if the belt holds the restraint in place. If the restraint is not secure, tighten the seat belt as necessary, or put the restraint in another seat and test it again. You may need to try a different child restraint. Not all child restraints fit in all types of vehicles.
7. Check to make sure that the child restraint is properly secured prior to each use. If the seat belt is not locked, repeat steps 1

through 6.

After the child restraint is removed and the seat belt fully retracted, the ALR mode (child restraint mode) is canceled.

FORWARD-FACING CHILD RESTRAINT INSTALLATION USING LATCH

Refer to all Warnings and Cautions in the “Child safety” and “Child restraints” sections before installing a child restraint.

Do not use the lower anchors if the combined weight of the child and the child restraint exceeds 65 lb (29.5 kg). If the combined weight of the child and the child restraint is greater than 65 lb (29.5 kg), use the vehicle’s seat belt (not the lower anchors) to install the child restraint. Be sure to follow the child restraint manufacturer’s instructions for installation.

Follow these steps to install a forward-facing child restraint using the LATCH system:

Before installing a child restraint system, remove the head restraint to obtain the correct child restraint fit. If the head restraint is removed, store it in a secure place. Be sure to reinstall the head restraint when the child restraint is removed. See “Head restraints” (P.1-12) for head restraint adjustment information.

1. Position the child restraint on the seat. Always follow the child restraint manufacturer’s instructions.
 - Adjust the seat where the child restraint system will be installed to the most rearward position.

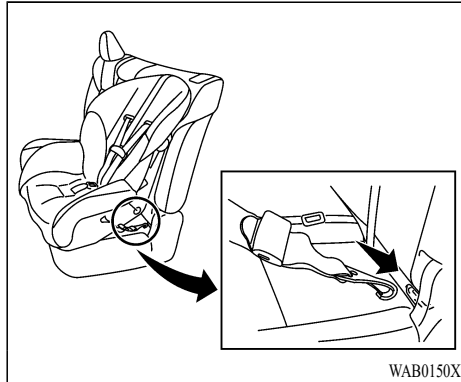

Forward-facing web-mounted — step 2

2. Secure the child restraint anchor attachments to the LATCH lower anchors. Check to make sure the LATCH attachment is properly attached to the lower anchors.

Do not attach the child restraint on the second row center seat.

If the child restraint is equipped with a top tether strap, route the top tether strap and secure the tether strap to the tether anchor point. See “Installing top tether strap” (P.1-38). Do not install child restraints that require the use of a top tether strap in seating positions that do not have a top tether anchor.

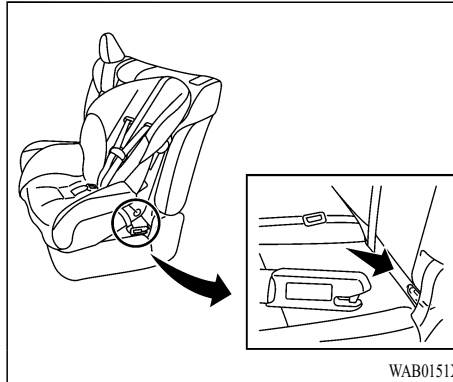

Forward-facing rigid-mounted — step 2

3. The back of the child restraint should be secured against the vehicle seatback. If the seating position is interfering with the proper child restraint fit, try another seating position or a different child restraint.

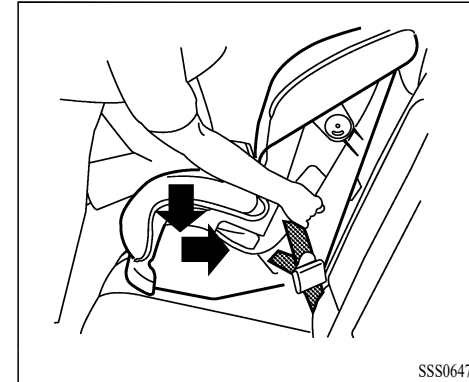

Forward-facing — step 4

4. For child restraints that are equipped with webbing-mounted attachments, remove any additional slack from the anchor attachments. Press downward and rearward firmly in the center of the child restraint with your knee to compress the vehicle seat cushion and seatback while tightening the webbing of the anchor attachments.
5. Tighten the tether strap according to the manufacturer’s instructions to remove any slack.

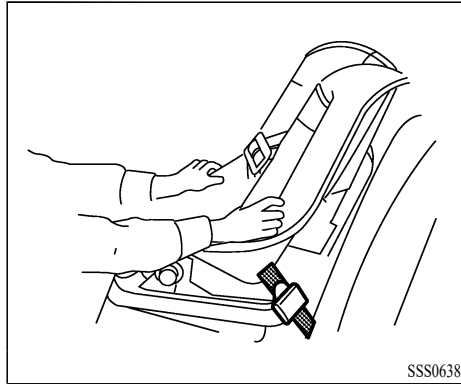

Forward-facing — step 6

6. After attaching the child restraint, test it before you place the child in it. Push it from side to side while holding the child restraint near the LATCH attachment path. The child restraint should not move more than 1 inch (25 mm), from side to side. Try to tug it forward and check to see if the LATCH attachment holds the restraint in place. If the restraint is not secure, tighten the LATCH attachment as necessary, or put the restraint in another seat and test it again. You may need to try a different child restraint. Not all child restraints fit in all types of vehicles.
7. Check to make sure the child restraint is properly secured prior to each use. If the child restraint is loose, repeat steps 1 through 6.

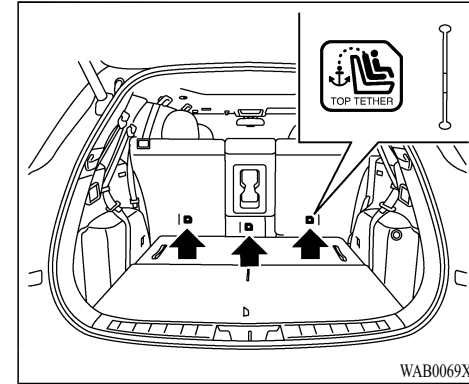

Installing top tether strap

WARNING

Child restraint anchorages are designed to withstand only those loads imposed by correctly fitted child restraints. Under no circumstances are they to be used to attach adult seat belts, or other items or equipment to the vehicle. Doing so could damage the child restraint anchorages. The child restraint will not be properly installed using the damaged anchorage, and a child could be seriously injured or killed in a collision.

The child restraint top tether strap must be used when installing the child restraint with the LATCH lower anchor attachments.

First, secure the child restraint with the LATCH lower anchors.

1. Remove the head restraint and store it in a secure place. Be sure to reinstall the head restraint when the child restraint is removed.
See “Head restraints” (P.1-12) for head restraint adjustment, removal and installation information.
2. Position the top tether strap over the seatback.
3. Secure the top tether strap to the tether anchor point shown on the illustration.
4. Refer to the appropriate child restraint installation procedure steps in this section before tightening the tether strap.

If you have any questions when installing a top tether strap, it is recommended that you visit an authorized Mitsubishi Motors dealer for this service.

FORWARD-FACING CHILD RESTRAINT INSTALLATION USING THE SEAT BELTS

WARNING

The three-point seat belt with Automatic Locking Retractor (ALR) must be used when installing a child restraint. Failure to use the ALR mode will result in the child restraint not being properly secured. The restraint could tip over or be loose and cause injury to a child in a sudden stop or collision. Also, it can change the operation of the front passenger airbag. See “Front passenger airbag status light” (P.1-55).

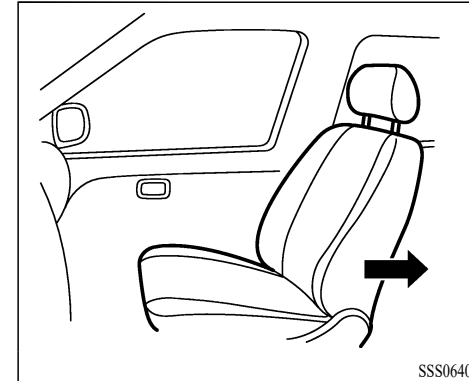

SSS0640

Forward-facing (front passenger seat) — step 1

Refer to all Warnings and Cautions in the “Child safety” and “Child restraints” sections before installing a child restraint.

Do not use the lower anchors if the combined weight of the child and the child restraint exceeds 65 lb (29.5 kg). If the combined weight of the child and the child restraint is greater than 65 lb (29.5 kg), use the vehicle’s seat belt (not the lower anchors) to install the child restraint. Be sure to follow the child restraint manufacturer’s instructions for installation.

Follow these steps to install a forward-facing child restraint using the vehicle seat belt in the front passenger seat, second row seats and third row seats:

Before installing a child restraint system, remove the head restraint to obtain the correct child restraint fit. If the head restraint is removed, store it in a secure place. Be sure to reinstall the head restraint when the child restraint is removed. See “Head restraints” (P.1-12) for head restraint adjustment information.

1. **If you must install a child restraint in the front seat, it should be placed in a forward-facing direction only. Move the seat to the rearmost position. Child restraints for infants must be used in the rear-facing direction and, therefore, must not be used in the front seat.**

2. Position the child restraint on the seat. Always follow the child restraint manufacturer’s instructions.
 - Adjust the seat where the child restraint system will be installed to the most rearward position.

The back of the child restraint should be secured against the vehicle seatback.

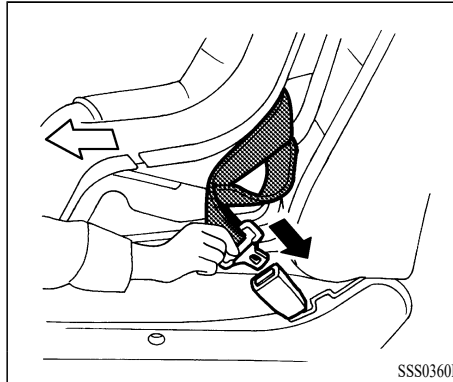

Forward-facing — step 3

3. Route the seat belt tongue through the child restraint and insert it into the buckle until you hear and feel the latch engage. Be sure to follow the child restraint manufacturer’s instructions for belt routing.

If the child restraint is equipped with a top tether strap, route the top tether strap and secure the tether strap to the tether anchor point (rear seat installation only). See “Installing top tether strap” (P.1-42). Do not install child restraints that require the use of a top tether strap in seating positions that do not have a top tether anchor.

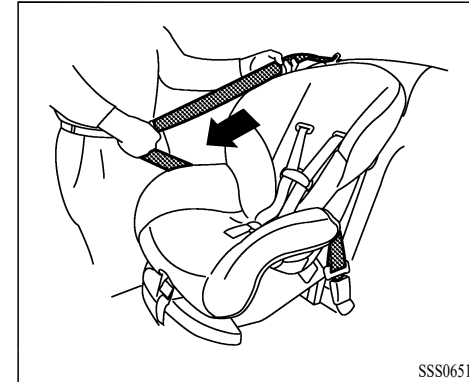

Forward-facing — step 4

4. Pull the shoulder belt until the belt is fully extended. At this time, the seat belt retractor is in the Automatic Locking Retractor (ALR) mode (child restraint mode). It reverts to Emergency Locking Retractor (ELR) mode when the seat belt is fully retracted.

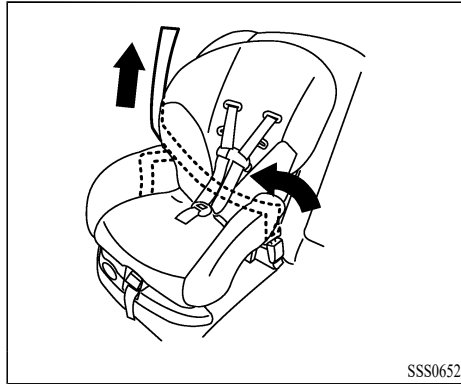

Forward-facing — step 5

5. Allow the seat belt to retract. Pull up on the shoulder belt to remove any slack in the belt.

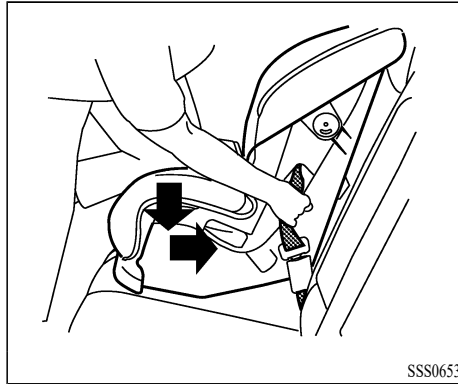

Forward-facing — step 6

6. Remove any additional slack from the seat belt; press downward and rearward firmly in the center of the child restraint with your knee to compress the vehicle seat cushion and seatback while pulling up on the seat belt.
7. Tighten the tether strap according to the manufacturer's instructions to remove any slack.

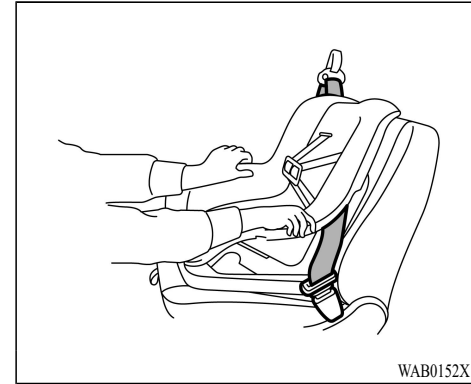

Forward-facing — step 8

8. After attaching the child restraint, test it before you place the child in it. Push it from side to side while holding the child restraint near the seat belt path. The child restraint should not move more than 1 inch (25 mm), from side to side. Try to tug it forward and check to see if the belt holds the restraint in place. If the restraint is not secure, tighten the seat belt as necessary, or put the restraint in another seat and test it again. You may need to try a different child restraint. Not all child restraints fit in all types of vehicles.

9. Check to make sure the child restraint is properly secured prior to each use. If the seat belt is not locked, repeat steps 2 through 8.



Forward-facing — step 10

10. If the child restraint is installed in the front passenger seat, place the ignition switch in the ON position. The front passenger airbag status light  should illuminate. If this light is not illuminated, see “Front passenger airbag status light” (P.1-55). **Move the child restraint to another seating position.** Have the system checked. It is recommended you visit an authorized Mitsubishi Motors dealer for this service.

After the child restraint is removed and the seat belt is fully retracted, the ALR mode (child restraint mode) is canceled.

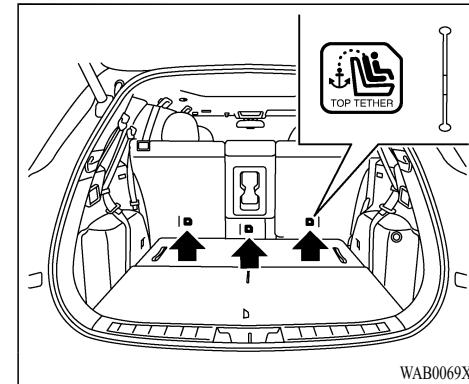

Installing top tether strap

WARNING

Child restraint anchorages are designed to withstand only those loads imposed by correctly fitted child restraints. Under no circumstances are they to be used to attach adult seat belts, or other items or equipment to the vehicle. Doing so could damage the child restraint anchorages. The child restraint will not be properly installed using the damaged anchorage, and a child could be seriously injured or killed in a collision.

The child restraint top tether strap must be used when installing the child restraint with the seat belts.

First, secure the child restraint with the seat belt.

1. Remove the head restraint and store it in a secure place. Be sure to reinstall the head restraint when the child restraint is removed.

See “Head restraints” (P.1-12) for head restraint adjustment, removal and installation information.

2. Position the top tether strap over the seatback.
3. Secure the top tether strap to the tether anchor point shown on the illustration.
4. Refer to the appropriate child restraint installation procedure steps in this section before tightening the tether strap.

If you have any questions when installing a top tether strap, it is recommended you visit an authorized Mitsubishi Motors dealer for this service.

BOOSTER SEATS

Precautions on booster seats

WARNING

If a booster seat and seat belt are not used properly, the risk of a child being injured or killed in a sudden stop or collision greatly increases:

- **Make sure the shoulder portion of the belt is away from the child’s face and neck and the lap portion of the belt does not cross the stomach.**
- **Make sure the shoulder belt is not behind the child or under the child’s arm.**
- **A booster seat must only be installed in a seating position that has a lap/shoulder belt.**

Booster seats of various sizes are offered by several manufacturers. When selecting any booster seat, keep the following points in mind:

- Choose only a booster seat with a label certifying that it complies with Federal Motor Vehicle Safety Standard 213 or Motor Vehicle Restraint Systems and Booster Seats Safety Regulations (RSSR).
- Check the booster seat in your vehicle to be sure it is compatible with the vehicle’s seat

and seat belt system.

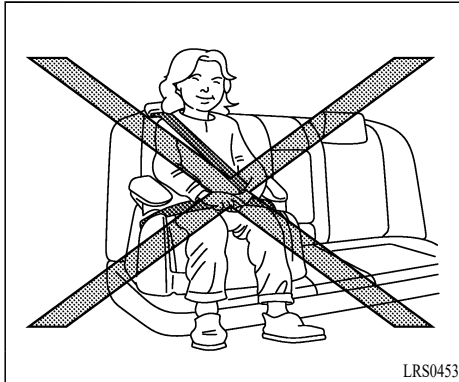

LRS0453

- Make sure the child's head will be properly supported by the booster seat or vehicle seat.
- If the booster seat is compatible with your vehicle, place your child in the booster seat and check the various adjustments to be sure the booster seat is compatible with your child. Always follow all recommended procedures.



LRS0464

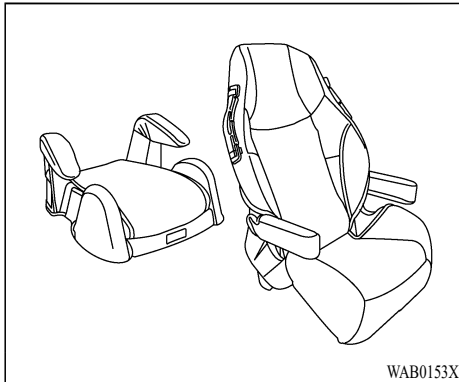

WAB0153X

All U.S. states and Canadian provinces or territories require that infants and small children be restrained in an approved child restraint at all times while the vehicle is being operated.

The instructions in this section apply to booster seat installation in the rear seats or the front passenger seat.

Booster seat installation

WARNING

To avoid injury to child, do not use the lap/shoulder belt Automatic Locking Retractor (ALR) mode when using a booster seat with the seat belts.

CAUTION

Do not remove the head restraint when installing a booster seat.

Refer to all Warnings and Cautions in the “Child safety”, “Child restraints” and “Booster seats” sections earlier in this section before installing a child restraint.

Follow these steps to install a booster seat in the rear seat or in the front passenger seat:

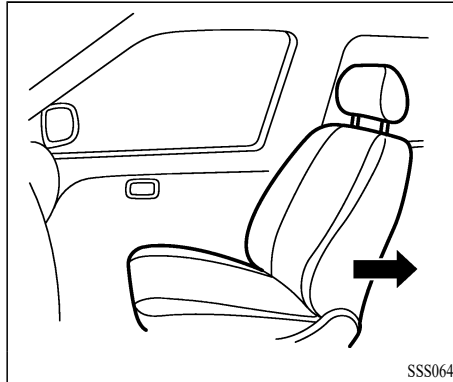

1. **If you must install a booster seat in the front seat, move the seat to the rearward position.**

Do not use the LATCH fixed booster seat on the second row center seat.

2. Position the booster seat on the seat. Only place it in a forward-facing direction. Always follow the booster seat manufacturer's instructions.
 - Adjust the seat where the child restraint system will be installed to the most rearward position.

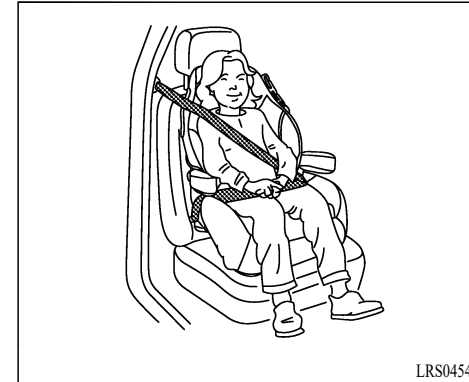

Front passenger position

3. The booster seat should be positioned on the vehicle seat so that it is stable.

If necessary, adjust or remove the head restraint to obtain the correct booster seat fit. If the head restraint is removed, store it in a secure place. **Be sure to reinstall the head restraint when the booster seat is removed.** See “Head restraints” (P.1-12) for head restraint adjustment, removal and installation information.

If the seating position does not have a head restraint and it is interfering with the proper booster seat fit, try another seating position or a different booster seat.

4. Position the lap portion of the seat belt low and snug on the child's hips. Be sure to follow the booster seat manufacturer's instructions for adjusting the seat belt routing.
5. Pull the shoulder belt portion of the seat belt toward the retractor to take up extra slack. Be sure the shoulder belt is positioned across the top, middle portion of the child's shoulder. Be sure to follow the booster seat manufacturer's instructions for adjusting the seat belt routing.
6. Follow the warnings, cautions and instructions for properly fastening a seat belt shown in "Seat belts" (P.1-16).



7. If the booster seat is installed in the front passenger seat, place the ignition switch in the ON position. The front passenger airbag status light  may or may not illuminate depending on the size of the child and the type of booster seat used. See "Front passenger airbag status light" (P.1-55).

SUPPLEMENTAL RESTRAINT SYSTEM (SRS)

PRECAUTIONS ON SRS

This SRS section contains important information concerning the following systems:

- Driver and front passenger SRS airbag (Advanced Airbag System)
- Driver and passenger SRS knee airbag
- Front seat-mounted SRS side airbag
- Second-row outboard seat-mounted SRS side airbag
- Front seat-mounted SRS center airbag (if so equipped)
- Side Curtain SRS airbag
- Seat belt pretensioner (front and second row outboard seats)

Driver and front passenger SRS airbag system: The Advanced Airbag System can help cushion the impact force to the head and chest of the driver and front passenger in certain frontal collisions.

Driver and passenger SRS knee airbag system: The SRS driver's and front passenger's knee airbags are designed to supplement the primary protection of the driver's and front passenger's seat belt system. It can reduce the forward movement of the driver's and front passenger's lower legs and provide increased overall body protection in certain moderate to severe frontal collisions.

Front seat-mounted SRS side airbag system: This system can help cushion the impact force to the chest and pelvic area of the driver and front passenger in certain side impact collisions. The side airbag is designed to inflate on the side where the vehicle is impacted.

Second-row outboard seat-mounted SRS side airbag system: This system can help cushion the impact force to the chest area of the second row outboard seat passengers in certain side-impact collisions. The side airbags are designed to inflate on the side where the vehicle is impacted.

Front seat-mounted SRS center airbag system (if so equipped): This system can help cushion the impact force to the head area of the driver and front passenger in certain side-impact collisions. The center side airbag is designed to inflate if left or right side of the vehicle is impacted.

Side Curtain SRS airbag system: This system can help cushion the impact force to the heads of occupants in front and second row outboard seating positions in certain side impact or rollover collisions. The curtain airbags are also designed to help reduce the risk of complete and partial ejection from the vehicle through side windows in both side impact and rollover type accidents. In a side-impact, the curtain airbags are designed to inflate on the side where the

vehicle is impacted. In a rollover, the curtain airbags on both sides are designed to inflate. Under both side-impact and rollover situations, the curtain airbags will remain inflated for a short period of time.

These supplemental restraint systems are designed to **supplement** the crash protection provided by the driver, passenger and second row outboard seat belts and are **not a substitute** for them. Seat belts should always be correctly worn and the occupant seated a suitable distance away from the steering wheel, instrument panel and door finishers. (See "Seat belts" (P.1-16) for instructions and precautions on seat belt usage.)

The airbags operate only when the ignition switch is in the ON or START position.

After the ignition is placed in the ON position, the SRS airbag warning light illuminates. The SRS airbag warning light will turn off after about 7 seconds if the systems are operational.

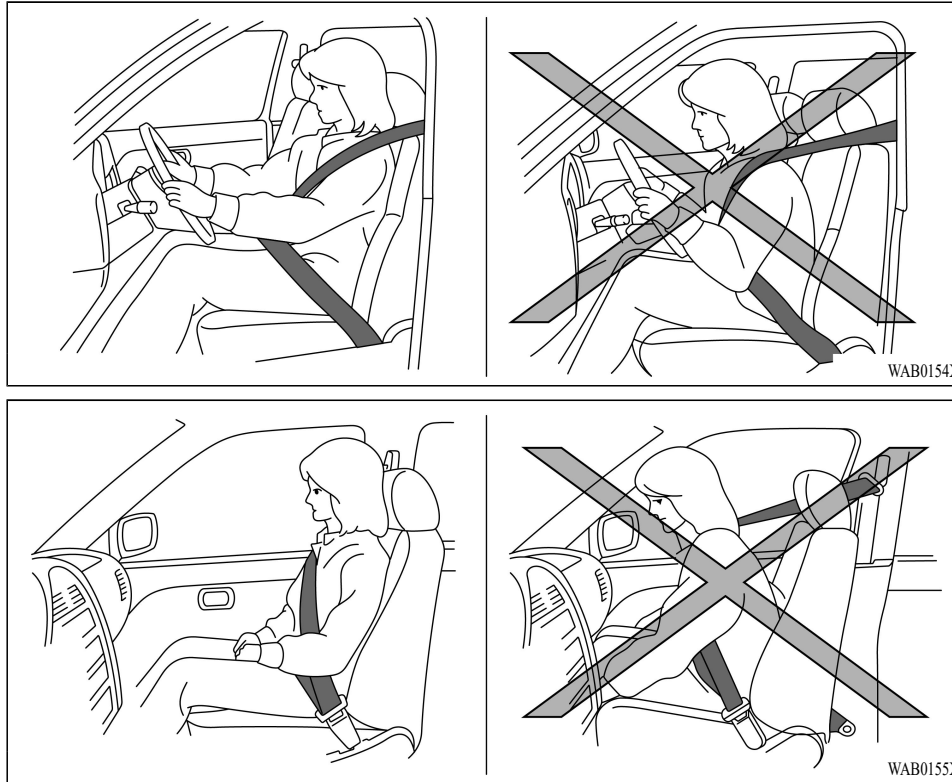

WARNING

- **IT IS VERY IMPORTANT TO ALWAYS WEAR YOUR SEAT BELT PROPERLY EVEN WITH AN AIRBAG.**

— Seat belts help keep the driver and passengers properly positioned. This reduces the risk of injury in all collisions, and reduces the risk of serious injuries or death when the airbags inflate. During sudden braking just before a collision, an unrestrained or improperly restrained driver or front passenger can move forward into direct contact with, or within close proximity to, the airbag when it begins to inflate.

The beginning stage of airbag inflation is the most forceful and can cause serious injuries or death if the occupant comes in contact with the airbag at this time.

— Seat belts reduce the risk of injury in rear impact collisions, and in low-speed frontal collisions because the airbags are not designed to inflate in those situations.

— Seat belts reduce the risk of being thrown from your vehicle in a collision or rollover.

- The front airbags ordinarily will not inflate in the event of a side impact, rear impact, rollover, or lower severity frontal collision. Always wear your seat belts to help reduce the risk or severity of injury in various kinds of accidents.
- The front passenger airbag and passenger knee airbag will not inflate if the front passenger airbag status light is lit. See “Front passenger airbag status light” (P.1-55).
- The seat belts and the front airbags are most effective when you are sitting well back and upright in the seat with both feet on the floor. The front airbags inflate with great force. Even with the Advanced Airbag System, if you are unrestrained, leaning forward, sitting sideways or out of position in any way, you are at greater risk of injury or death in a crash. You may also receive serious or fatal injuries from the front airbag if you are up against it when it inflates. Always sit back against the seatback and as far-away as practical from the steering wheel or instrument panel. Always use the seat belts.
- The driver and front passenger seat belt buckles are equipped with sensors that detect if the seat belts are fastened. The

Advanced Airbag System monitors the severity of a collision and seat belt usage then inflates the airbags as needed. Failure to properly wear seat belts can increase the risk or severity of injury in an accident.

- The front passenger seat is equipped with occupant classification sensors (weight sensors) that turn the front passenger airbag and passenger knee airbag OFF under some conditions. These sensors are only used in this seat. Failure to be properly seated and wearing the seat belt can increase the risk or severity of injury in an accident. See “Front passenger airbag status light” (P.1-55).
- Keep hands on the outside of the steering wheel. Placing them inside the steering wheel rim could increase the risk that they are injured if the front airbag inflates.

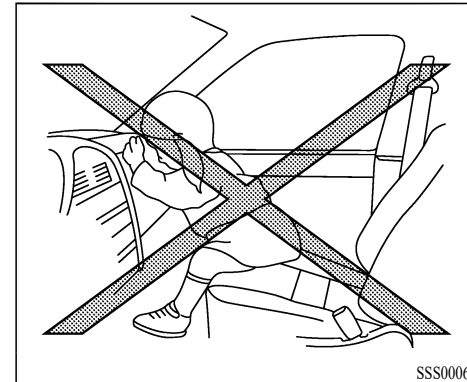
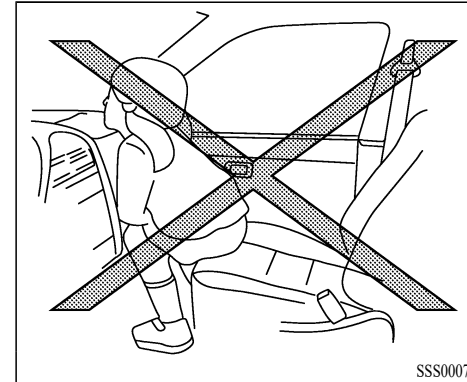

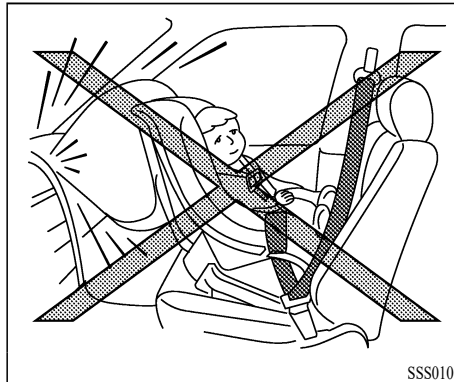
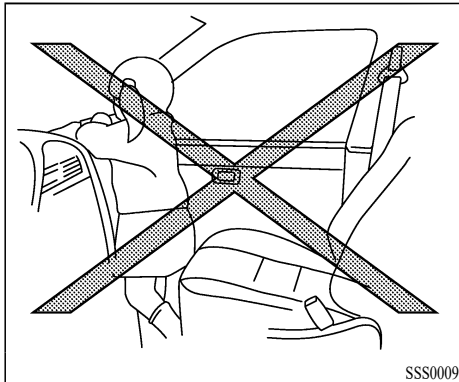
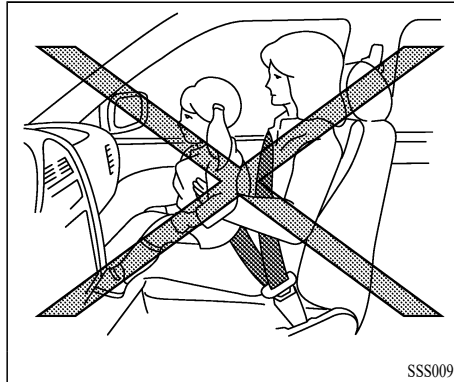
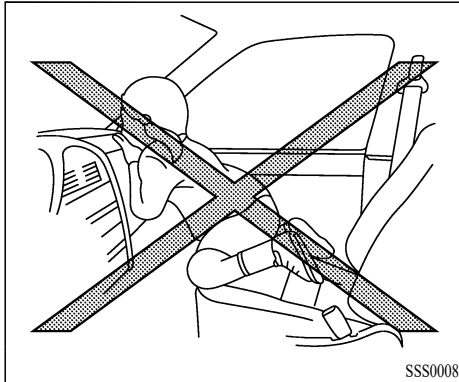

WARNING

- Never let children ride unrestrained or extend their hands or face out of the window. Do not attempt to hold them in your lap or arms. Some examples of dangerous riding positions are shown in the illustrations.
- Children may be severely injured or killed when the front airbags, side airbags or curtain airbags inflate if they are not properly restrained. Pre-teens and children should be properly restrained in the rear seat, if possible.
- Even with the Advanced Airbag System, never install a rear-facing child restraint or infant restraint in the front seat. An inflating front airbag could seriously injure or kill your child. See “Child restraints” (P.1-27) for details.

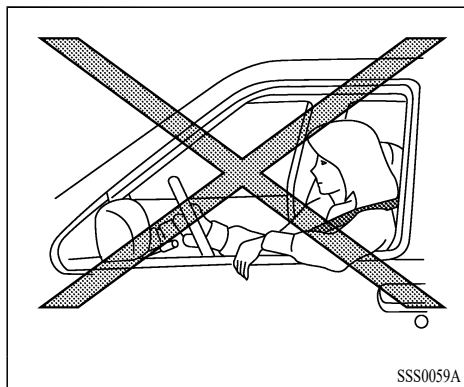

Do not lean against doors or windows.

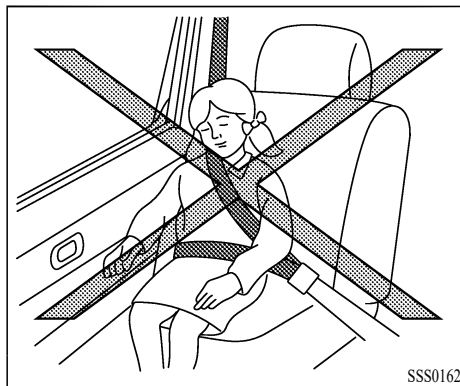
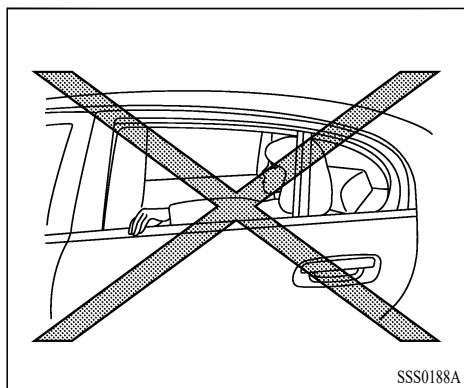
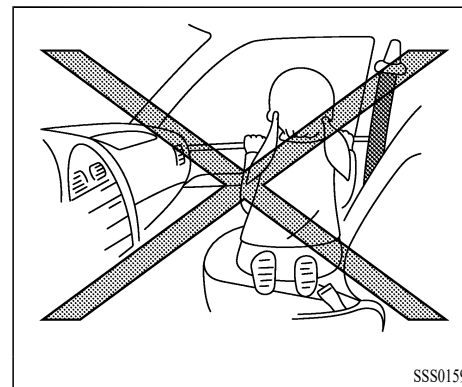
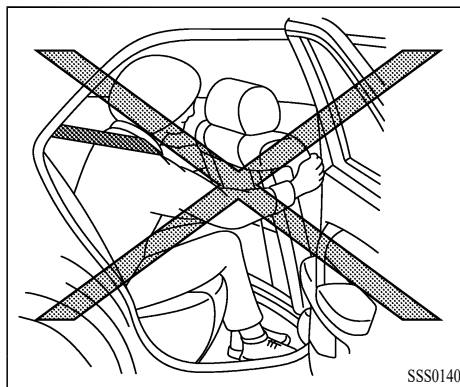

⚠ WARNING

Front and second row seat side aibags and curtain aibags:

- The side aibags ordinarily will not inflate in the event of a frontal impact, rear impact, rollover or lower severity side collision. Always wear your seat belts to help reduce the risk or severity of injury in various kinds of accidents.
- The curtain aibags ordinarily will not inflate in the event of a front impact, rear impact, or lower severity side collision. Always wear your seat belts to help reduce the risk or severity of injury in various

kinds of accidents.

- The seat belts, the side airbags and curtain airbags are most effective when you are sitting well back and upright in the seat. The side airbags and curtain airbags inflate with great force. Do not allow anyone to place their hand, leg or face near the side airbags on the side of the seatback of the front and second row seat or near the side roof rails. Do not allow anyone sitting in the front seats or second row outboard seats to extend their hand out of the window or lean against the door. The side airbags and curtain airbags can cause serious injury or death to anyone too close to the airbag when it deploys. Some examples of dangerous riding positions are shown in the previous illustrations.
- Do not place stickers, labels or additional trim on the back of either front seat. They can interfere with proper side airbag deployment.
- When sitting in the rear seat, do not hold onto the seatback of the seat in front of you. If the center airbag or the side airbags inflate, you may be seriously injured. Be especially careful with children, who should always be properly restrained. Some examples of dangerous riding positions are shown in the illustrations.
- Do not use seat covers on the front and second row seatbacks. They may interfere with side airbag inflation.

- Do not allow a child to lean against or sit close to the passenger door, even if the child is seated in a child restraint system. The child's head should also not lean against or be close to the section of the seatback where the side airbag and curtain airbag are located. It is dangerous if the side airbag or curtain airbag deploys. Failure to follow all of these instructions could lead to serious injury or death to the child.

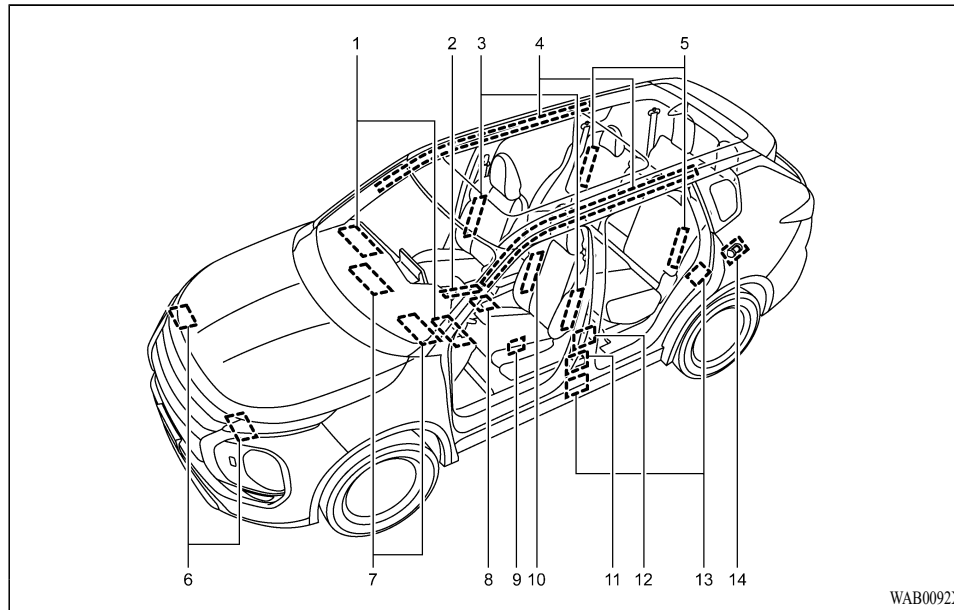

- | | |
|---|--|
| 1. Driver and front passenger SRS airbag modules | 6. Crash zone sensor |
| 2. Occupant classification sensors (weight sensors) | 7. Driver and passenger SRS knee airbags |
| 3. Front seat-mounted SRS side airbag modules | 8. Airbag Control Unit (ACU) |
| 4. Side Curtain SRS airbag modules | 9. Front door pressure sensors (left side shown; right side similar) |
| 5. Second-row outboard seat-mounted SRS side airbag modules | 10. Front seat-mounted SRS center airbag (if so equipped) |

11. Lap outer pretensioners (left side shown; right side similar)
12. Seat belt pretensioners (left side shown; right side similar)
13. Side impact sensors (left side shown; right side similar)
14. Seat belt pretensioners (second row outboard seats) (left side shown; right side similar)

ADVANCED AIRBAG SYSTEM (front seats)

WARNING

To ensure proper operation of the passenger's Advanced Airbag System, please observe the following items.

- Do not allow a passenger in the rear seat to push or pull on the seatback pockets.
- Do not place heavy loads heavier than 9.1 lb (4 kg) in total on the seatback, head restraint or in the seatback pockets.
- Make sure nothing is pressing against the rear of the seatback, such as a child restraint installed in the rear seat or an object stored on the floor.
- Make sure that there is no object placed under the front passenger seat.
- Make sure that there is no object placed between the seat cushion and center console or between the seat cushion and

the door.

- Be sure that the front passenger seat does not contact the rear seat, instrument panel, etc., or the head restraint does not contact the roof.
- Do not position the front passenger seat so it contacts the rear seat. If the front seat does contact the rear seat, the airbag system may determine a sensor malfunction has occurred and the front passenger airbag status light may illuminate and the SRS airbag warning light may flash.
- If a forward facing child restraint is installed in the front passenger seat, do not position the front passenger seat so the child restraint contacts the instrument panel. If the child restraint does contact the instrument panel, the system may determine the seat is occupied and the passenger airbag and passenger knee airbag may deploy in a collision. Also the front passenger airbag status light may not illuminate. See “Child restraints” (P.1-27) for information about installing and using child restraints.
- Confirm the operating condition with the front passenger airbag status light.
- If you notice that the front passenger airbag status light is not operating as described in this section, it is recommended you visit an authorized Mitsubishi Motors dealer to check the passenger seat Advanced Airbag System.

- **Until you have confirmed with your dealer that your passenger seat Advanced Airbag is working properly, position the occupants in the rear seating positions.**

This vehicle is equipped with the Advanced Airbag System for the driver and front passenger seats. This system is designed to meet certification requirements under U.S. regulations. It is also permitted in Canada. **All of the information, cautions and warnings in this manual apply and must be followed.**

The driver SRS airbag is located in the center of the steering wheel. The front passenger SRS airbag is mounted in the instrument panel above the glove box. The front airbags are designed to inflate in higher severity frontal collisions, although they may inflate if the forces in another type of collision are similar to those of a higher severity frontal impact. They may not inflate in certain frontal collisions. Vehicle damage (or lack of it) is not always an indication of proper front airbag operation.

The Advanced Airbag System has dual stage airbag inflators. The system monitors information from the Airbag Control Unit (ACU), seat belt buckle sensors and the occupant classification sensors (weight sensors). Inflator operation is based on the severity of a collision and seat belt usage for the driver. For the front

passenger, the occupant classification sensors are also monitored. Based on information from the sensors, only one front airbag may inflate in a crash, depending on the crash severity and whether the front occupants are belted or unbelted. Additionally, the front passenger airbag and passenger knee airbag may be automatically turned OFF under some conditions, depending on the information provided by the occupant classification sensors. If the front passenger airbag and passenger knee airbag are OFF, the front passenger airbag status light will be illuminated. (See “Front passenger airbag status light” (P.1-55) for further details.) One front airbag inflating does not indicate improper performance of the system.

If you have any questions about your airbag system, it is recommended you visit an authorized Mitsubishi Motors dealer to obtain information about the system. If you are considering modification of your vehicle due to a disability, you may also contact Mitsubishi Motors. Contact information is contained in the front of this Owner’s Manual.

When a front airbag inflates, a fairly loud noise may be heard, followed by release of smoke. This smoke is not harmful and does not indicate a fire. Care should be taken not to inhale it, as it may cause irritation and choking. Those with a history of a breathing condition should get fresh air promptly.

Front SRS airbags, along with the use of seat belts, help to cushion the impact force on the head and chest of the front occupants. They can help save lives and reduce serious injuries. However, an inflating front airbag may cause facial abrasions or other injuries. Front airbags, other than the driver's and front passenger's knee airbags, do not provide restraint to the lower body.

Even with Advanced Airbags, seat belts should be correctly worn and the driver and passenger seated upright as far as practical away from the steering wheel or instrument panel. The front airbags inflate quickly in order to help protect the front occupants. Because of this, the force of the front airbag inflating can increase the risk of injury if the occupant is too close to, or is against, the airbag module during inflation.

The front airbags deflate quickly after a collision.

The front airbags operate only when the ignition switch is in the ON position.

After the ignition is placed in the ON position, the SRS airbag warning light illuminates. The SRS airbag warning light will turn off after about 7 seconds if the system is operational.



Front passenger airbag status light

Front passenger airbag status light

WARNING

- The front passenger airbag and passenger knee airbag are designed to automatically turn OFF under some conditions. Read this section carefully to learn how it operates. Proper use of the seat, seat belt and child restraints is necessary for most effective protection. Failure to follow all instructions in this manual concerning the use of seats, seat belts and child restraints can increase the risk or severity of injury in an accident.

- The front passenger airbag status light comes on and goes out repeatedly.
- Do not attach any accessory near the front passenger airbag status light that makes the front passenger airbag status light difficult or impossible to see. You must be able to see the front passenger airbag status light and verify the status of the front passenger's airbag system.

Status light:

The front passenger seat is equipped with occupant classification sensors (weight sensors) that turn the front passenger airbag and passenger knee airbag on or off depending on the weight applied to the front passenger seat. The status of the front passenger airbag and passenger knee airbag (ON or OFF) is indicated by the front passenger airbag status light  which is located near by the inside mirror. After the ignition switch is placed in the ON position, the front passenger airbag status light illuminates for about 7 seconds and then turns off or remains illuminate depending on the front passenger seat occupied status. The light operates as follows:

CONDITION	DESCRIPTION	PASSENGER AIRBAG INDICATOR LIGHT (^{OFF}_{OFF})	FRONT PASSENGER AIRBAG AND PASSENGER KNEE AIR- BAG STATUS
Empty	Empty front passenger seat	ON (illuminated)	INHIBITED
Nobody/Somebody	Bag or Child or Child Restraint or Small Adult in front passenger seat	ON (illuminated)	INHIBITED
Adult	Adult in the front passenger seat	OFF (dark)	ACTIVATED

In addition to the above, certain objects placed on the front passenger seat may also cause the light to operate as described above depending on their weight.

For additional information related to the normal operation and troubleshooting of this occupant classification sensor system, please refer to “Normal operation” (P.1-59) and “Troubleshooting” (P.1-60) in this section.

Front passenger airbag:

The front passenger airbag is designed to automatically turn OFF when the vehicle is operated under some conditions as described below as permitted by U.S. regulations. If the front passenger airbag is OFF, it will not inflate in a crash. The driver airbag and other airbags in your vehicle are not part of this system.

The purpose of the regulation is to help reduce the risk of injury or death from an inflating airbag to certain front passenger seat occupants, such as children, by requiring the airbag to be automatically turned OFF.

The occupant classification sensors (weight sensors) are on the seat cushion frame under the front passenger seat and are designed to detect an occupant and objects on the seat. For example, if a child is in the front passenger seat, the Advanced Airbag System is designed to turn the passenger airbag OFF in accordance with

the regulations. Also, if a child restraint of the type specified in the regulations is on the seat, the occupant classification sensors can detect it and cause the airbag to turn OFF.

Front passenger seat adult occupants who are properly seated and using the seat belt as outlined in this manual should not cause the passenger airbag and passenger knee airbag to be automatically turned OFF. For small adults it may be turned OFF, however, if the occupant does not sit in the seat properly (for example, by not sitting upright, by sitting on an edge of the seat, or by otherwise being out of position), this could cause the sensors to turn the airbag OFF. Always be sure to be seated and wearing the seat belt properly for the most effective protection by the seat belt and airbag.

Mitsubishi Motors recommends that pre-teens and children be properly restrained in a rear seat. Mitsubishi Motors also recommends that appropriate child restraints and booster seats be properly installed in a rear seat. If this is not possible, the occupant classification sensors are designed to operate as described above to turn the front passenger airbag and passenger knee airbag OFF for specified child restraints. Failing to properly secure child restraints and to use the Automatic Locking Retractor (ALR) mode (child restraint mode) may allow the restraint to tip or move in an accident or sudden stop. This can also result in the passenger airbag and

passenger knee airbag inflating in a crash instead of being OFF. (See “Child restraints” (P.1-27) for proper use and installation.)

If the front passenger seat is not occupied, the passenger airbag and passenger knee airbag are designed not to inflate in a crash. However, heavy objects placed on the seat could result in airbag inflation, because of the object being detected by the occupant classification sensors. Other conditions could also result in airbag inflation, such as if a child is standing on the seat, or if two children are on the seat, contrary to the instructions in this manual. Always be sure that you and all vehicle occupants are seated and restrained properly.

Using the front passenger airbag status light, you can monitor when the front passenger airbag and passenger knee airbag are automatically turned OFF.

If an adult occupant is in the seat but the front passenger airbag status light is illuminated (indicating that the front passenger airbag and passenger knee airbag are OFF), it could be that the person is a small adult, or is not sitting on the seat properly.

If a child restraint must be used in the front seat, the front passenger airbag status light may or may not be illuminated, depending on the size of the child and the type of child restraint being used. If the front passenger airbag status light is

not illuminated (indicating that the airbag might inflate in a crash), it could be that the child restraint or seat belt is not being used properly. Make sure that the child restraint is installed properly, the seat belt is used properly and the occupant is positioned properly. If the front passenger airbag status light is not illuminated, reposition the occupant or child restraint in a rear seat.

If the front passenger airbag status light will not illuminate even though you believe that the child restraint, the seat belts and the occupant are properly positioned, it is recommended that you take your vehicle to an authorized Mitsubishi Motors dealer. A authorized Mitsubishi Motors dealer can check the system status by using a special tool. However, until you have confirmed with your dealer that your airbag is working properly, reposition the occupant or child restraint in a rear seat.

The Advanced Airbag System and front passenger airbag status light will take a few seconds to register a change in the passenger seat status. This is normal system operation and does not indicate a malfunction.

If a malfunction occurs in the front passenger airbag system, the SRS airbag warning light , located in the meters and gauges area, will illuminate. Have the system checked. It is recommended you visit an authorized

Mitsubishi Motors dealer for this service.

Normal operation:

In order for the occupant classification sensor system to classify the front passenger based on weight, please follow the precautions and steps outlined below:

Precautions:

- Make sure that there are no objects weighing over 9.1 lb (4 kg) hanging on the seat or placed in the seatback pockets.
- Make sure that a child restraint or other object is not pressing against the rear of the seatback.
- Make sure that a rear passenger is not pushing or pulling on the back of the front passenger seat.
- Make sure that the front passenger seat or seatback is not forced back against an object on the seat or floor behind it.
- Make sure that there is no object placed under the front passenger seat.
- Make sure that the front passenger seat head restraint does not contact the roof when adjusting the front passenger seat.

Steps:

1. Adjust the seat as outlined. (See “Seats” (P.1-2).) Sit upright, leaning against the seatback, and centered on the seat cushion with your feet comfortably extended to the floor.
2. Make sure there are no objects on your lap.
3. Fasten the seat belt as outlined. (See “Seat belts” (P.1-16).) Front passenger seat belt buckle status is monitored by the occupant classification system, and is used as an input to determine occupancy status. So, it is highly recommended that the front passenger fasten their seat belt.
4. Remain in this position for 30 seconds allowing the system to classify the front passenger before the vehicle is put into motion.
5. Ensure proper classification by checking the front passenger airbag status light.

NOTE:

This vehicle’s occupant classification sensor system locks the classification during driving so it is important that you confirm that the front passenger is properly classified prior to driving. Also, the occupant classification sensor system may recalculate the weight of the occupant under some conditions (both while driving and when stopped), so the front

passenger seat occupant should continue to remain seated as outlined above.

Troubleshooting:

If you think the front passenger airbag status light is incorrect:

1. If the light is ON with an adult occupying the front passenger seat:
 - Occupant is a small adult — the front passenger airbag status light is functioning as intended. The front passenger airbag and passenger knee airbag are suppressed.

However, if the occupant is not a small adult, then this may be due to the following conditions that may be interfering with the weight sensors:

- Occupant is not sitting upright, leaning against the seatback, and centered on the seat cushion with his/her feet comfortably extended to the floor.
- A child restraint or other object pressing against the rear of the seatback.
- A rear passenger pushing or pulling on the back of the front passenger seat.
- Forcing the front seat or seatback against an object on the seat or floor behind it.
- An object placed under the front passenger seat.
- An object placed between the seat cushion and center console or between the seat cushion and the door.

If the vehicle is moving, please come to a stop when it is safe to do so. Check and correct any of the above conditions. Restart the vehicle and wait 1 minute.

NOTE:

A system check will be performed during which the front passenger airbag status light will remain lit for about 7 seconds initially.

If the light is still ON after this, the person should be advised not to ride in the front passenger seat and it is recommended that the vehicle should be checked by an authorized Mitsubishi Motors dealer as soon as possible.

2. If the light is OFF with a small adult, child or child restraint occupying the front passenger seat.

This may be due to the following conditions that may be interfering with the weight sensors:

- Small adult or child is not sitting upright, leaning against the seatback, and centered on the seat cushion with his/her feet comfortably extended to the floor.
- The child restraint is not properly installed, as outlined. (See “Child restraints” (P.1-27).)
- An object weighing over 9.1 lb (4 kg) hanging on the seat or placed in the seatback pockets.

- A child restraint or other object pressing against the rear of the seatback.
- A rear passenger pushing or pulling on the back of the front passenger seat.
- Forcing the front seat or seatback against an object on the seat or floor behind it.
- An object placed under the front passenger seat.
- An object placed between the seat cushion and center console.
- The front passenger seat head restraint contacting the roof.

If the vehicle is moving, please come to a stop when it is safe to do so. Check and correct any of the above conditions. Restart the vehicle and wait 1 minute.

NOTE:

A system check will be performed during which the front passenger airbag status light will remain lit for about 7 seconds initially.

If the light is still OFF after this, the small adult, child or child restraint should be repositioned in the rear seat and it is recommended that the vehicle should be checked by an authorized Mitsubishi Motors dealer as soon as possible.

Other front airbag precautions

WARNING

- Do not place any objects on the steering wheel pad or on the instrument panel. Also, do not place any objects between any occupant and the steering wheel or instrument panel. Such objects may become dangerous projectiles and cause injury if the front airbags inflate.
- Do not place objects with sharp edges on the seat. Also, do not place heavy objects on the seat that will leave permanent impressions in the seat. Such objects can damage the seat or occupant classification sensors (weight sensors). This can affect the operation of the airbag system and result in serious personal injury.
- Do not use water or acidic cleaners (hot steam cleaners) on the seat. This can damage the seat or occupant classification sensors. This can also affect the operation of the airbag system and result in serious personal injury.
- Immediately after inflation, several front airbag system components will be hot. Do not touch them; you may severely burn yourself.
- No unauthorized changes should be made to any components or wiring of the airbag system. This is to prevent accidental

inflation of the airbag or damage to the airbag system.

- Do not make unauthorized changes to your vehicle's electrical system, suspension system or front end structure. This could affect proper operation of the front airbag system.
- Tampering with the front airbag system may result in serious personal injury. Tampering includes changes to the steering wheel and the instrument panel assembly by placing material over the steering wheel pad and above the instrument panel or by installing additional trim material around the airbag system.
- Removing or modifying the front passenger seat may affect the function of the airbag system and result in serious personal injury.
- Modifying or tampering with the front passenger seat may result in serious personal injury. For example, do not change the front seats by placing material on the seat cushion or by installing additional trim material, such as seat covers, on the seat that is not specifically designed to assure proper airbag operation. Additionally, do not stow any objects under the front passenger seat or the seat cushion and seatback. Such objects may interfere with the proper operation of the occupant classification sensors.

- No unauthorized changes should be made to any components or wiring of the seat belt system. This may affect the front airbag system. Tampering with the seat belt system may result in serious personal injury.
- It is recommended you visit an authorized Mitsubishi Motors dealer for work on and around the front airbag. It is also recommended you visit an authorized Mitsubishi Motors dealer for installation of electrical equipment. The Supplemental Restraint System (SRS) wiring harnesses* should not be modified or disconnected. Unauthorized electrical test equipment and probing devices should not be used on the airbag system.
- A cracked windshield should be replaced immediately by a qualified repair facility. A cracked windshield could affect the function of the airbag system.
- Never have more than one person (adult or child) sitting on the seat.
- Do not remove the head restraints.
- Do not remove the seats and seatbelts.
- Do not modify or replace the seat and seat belt.
- Do not place the floor mat on the seat rails.
- Do not subject the sensors for shock.

***The SRS wiring harness connectors are yellow and orange for easy identification.**

When selling your vehicle, we request that you inform the buyer about the front airbag system and guide the buyer to the appropriate sections in this Owner's Manual.

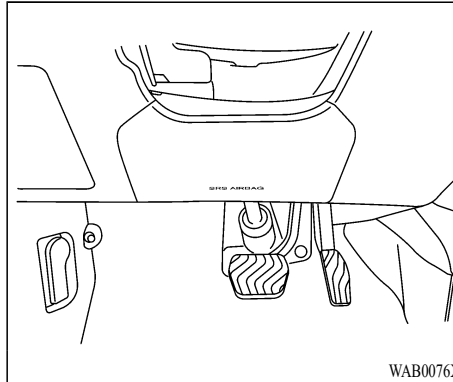

Driver's side

DRIVER AND FRONT PASSENGER SRS KNEE AIRBAG

The SRS knee airbags are located in the knee bolster, on the driver's and passenger's sides. **All of the information, cautions and warnings in this manual apply and must be followed.** The knee airbags are designed to inflate in higher severity frontal collisions, although it may inflate if the forces in another type of collision are similar to those of a higher severity frontal impact. They may not inflate in certain collisions.

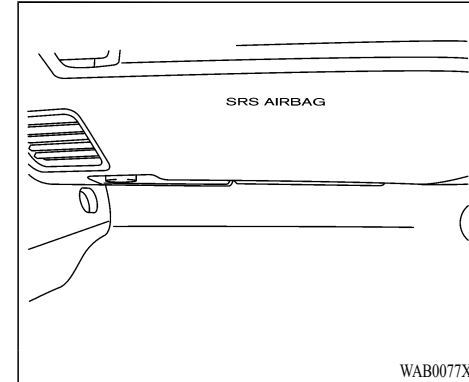

Passenger's side

Vehicle damage (or lack of it) is not always an indication of proper knee airbag operation.

When the knee airbags inflate, a fairly loud noise may be heard, followed by release of smoke. This smoke is not harmful and does not indicate a fire. Care should be taken not to inhale it, as it may cause irritation and choking. Those with a history of a breathing condition should get fresh air promptly.

The SRS driver's and front passenger's knee airbags are designed to supplement the primary protection of the driver's and front passenger's seat belt system. It can reduce the forward movement of the driver's and front passenger's lower legs and provide increased overall body

protection in certain moderate to severe frontal collisions.

The knee airbags inflate quickly in order to help protect the occupants. Because of this, the force of the knee airbag inflating can increase the risk of injury if the occupant is too close to, or is against, this airbag module during inflation. The knee airbag will deflate quickly after the collision is over OR the knee airbag will remain inflated for a short time.

The knee airbags operate only when the ignition switch is placed in the ON position. After placing the ignition switch in the ON position, the SRS airbag warning light illuminates. The SRS airbag warning light will turn off after about 7 seconds if the system is operational.

WARNING

- Do not place any objects between the knee bolster and the driver's or passenger's seat. Such objects may become dangerous projectiles and cause injury if a knee airbag inflates.
- Right after inflation, the knee airbag system components will be hot. Do not touch them; you may severely burn yourself.

- No unauthorized changes should be made to any components or wiring of the knee airbag system. This is to prevent damage to or accidental inflation of the knee airbag system.
- Do not make unauthorized changes to your vehicle's electrical system or suspension system. This could affect proper operation of the knee airbag system.
- Tampering with the knee airbag system may result in serious personal injury. For example, do not change the driver or passenger knee bolster or install additional trim material around the knee airbag.
- It is recommended that you visit an authorized Mitsubishi Motors dealer for work on and around the knee airbag. It is also recommended that you visit an authorized Mitsubishi Motors dealer for installation of electrical equipment. The SRS wiring harnesses* should not be modified or disconnected. Unauthorized electrical test equipment and probing devices should not be used on the knee airbag system.

***The SRS wiring harness or connectors are yellow or orange for easy identification.**

When selling your vehicle, we request that you inform the buyer about the knee airbag system and guide the buyer to the appropriate sections in this manual.

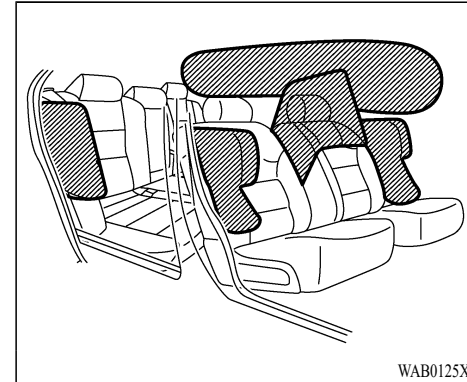

FRONT AND SECOND ROW SEAT-MOUNTED SIDE AIRBAG, FRONT SEAT-MOUNTED CENTER AIRBAG* AND SIDE CURTAIN SRS AIRBAG SYSTEMS

*: If so equipped

The front and second row seat-mounted SRS side airbags are located in the outside of the seatback of the front and second row seats. The front seat-mounted SRS center airbag (if so equipped) is located in the right side of the seatback of the driver's seat. The side curtain SRS airbags are located in the side roof rails.

All of the information, cautions and warnings in this manual apply and must be followed. The side airbags and curtain airbags are designed to inflate in higher severity side collisions, although they may inflate if the forces in another type of collision are similar to those of a higher severity side impact. They are designed to inflate on the side where the vehicle is impacted. They may not inflate in certain side collisions.

Side curtain SRS airbags are also designed to inflate in certain types of rollover collisions or near rollovers. As a result, certain vehicle movements (for example, during severe off-roading) may cause the curtain airbags to inflate.

Vehicle damage (or lack of it) is not always an indication of proper side airbag and curtain airbag operation.

When the side airbags and curtain airbags inflate, a fairly loud noise may be heard, followed by release of smoke. This smoke is not harmful and does not indicate a fire. Care should be taken not to inhale it, as it may cause irritation and choking. Those with a history of a breathing condition should get fresh air promptly.

Front and second row outboard seat-mounted side airbags, along with the use of seat belts, help to cushion the impact force on the chest

and pelvic area of the front and second row outboard occupants. Front seat-mounted center airbag, along with the use of seat belts, helps to cushion the impact force on the head area of the front occupants. Curtain airbags help to cushion the impact force to the head, chest and pelvic area of occupants in the front and second row outboard seating positions. They can help save lives and reduce serious injuries. However, an inflating side airbag or curtain airbag may cause abrasions or other injuries. Side airbags and curtain airbags do not provide restraint to the lower body.

The seat belts should be correctly worn and the driver, front passenger and second row outboard occupants seated upright as far as practical away from the side airbags. Second row seat passengers should be seated as far away as practical from the door finishers and side roof rails. The side airbags and curtain airbags inflate quickly in order to help protect the occupants. Because of this, the force of the side airbags and curtain airbags inflating can increase the risk of injury if the occupant is too close to, or is against, these airbag modules during inflation. The front and second row outboard side airbags will deflate quickly after the collision is over. The front center airbag and curtain airbag will remain inflated for a short time.

The side airbags and curtain airbags operate

only when the ignition switch is in the ON position.

After placing the ignition switch in the ON position, the SRS airbag warning light illuminates. The SRS airbag warning light will turn off after about 7 seconds if the systems are operational.

WARNING

- **Do not place any objects near the seatback of the front and second row seats. Also, do not place any objects (an umbrella, bag, etc.) between the front and rear door finisher, the center console, and the front and second row seats. Such objects may become dangerous projectiles and cause injury if a side airbag inflates.**
- **Right after inflation, several side airbag and curtain airbag system components will be hot. Do not touch them; you may severely burn yourself.**
- **No unauthorized changes should be made to any components or wiring of the side airbag and curtain airbag systems. This is to prevent damage to or accidental inflation of the side airbag and curtain airbag systems.**
- **Do not make unauthorized changes to your vehicle's electrical system, suspension system or side panel. This could affect proper**

operation of the side airbag and curtain airbag systems.

- Tampering with the side airbag system may result in serious personal injury. For example, do not change the front and second row seats by placing material near the seatbacks or by installing additional trim material, such as seat covers, around the side airbag.
- Removing or modifying the front and rear passenger seat may affect the function of the airbag system and result in serious personal injury.
- It is recommended you visit an authorized Mitsubishi Motors dealer for work on and around the side airbag and curtain airbag. It is also recommended you visit an authorized Mitsubishi Motors dealer for installation of electrical equipment. The Supplemental Restraint System (SRS) wiring harnesses* should not be modified or disconnected. Unauthorized electrical test equipment and probing devices should not be used on the side airbag or curtain airbag systems.

***The SRS wiring harness connectors are yellow and orange for easy identification.**

When selling your vehicle, we request that you inform the buyer about the side airbag and curtain airbag systems and guide the buyer to the appropriate sections in this Owner's Man-

ual.

SRS AIRBAG DEPLOYMENT CONDITIONS

The SRS airbags activate in the event of a front or side impact in which the vehicle occupants may be severely injured even if they are wearing the seat belts properly.

They may not activate when the crash energy is absorbed and/or distributed by the vehicle body. Vehicle damage (or lack of it) is not always an indication of proper SRS airbag system operation.

When the SRS airbag will deploy

Driver and front passenger airbags and knee airbags:

The driver and front passenger airbag and knee airbag systems are designed to inflate in higher severity frontal collisions. Some examples are shown in the following illustrations.

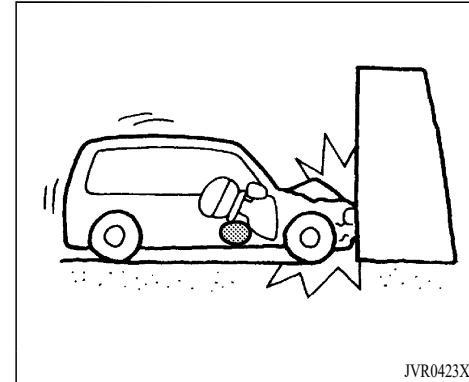

The driver and front passenger airbag and knee airbag systems will deploy in the event of an impact which exceeds a 16 MPH (25 km/h) frontal collision with a solid wall that does not move or deform.

The driver and front passenger airbag and knee airbag systems may also deploy when the vehicle receives severe damage to the undercarriage.

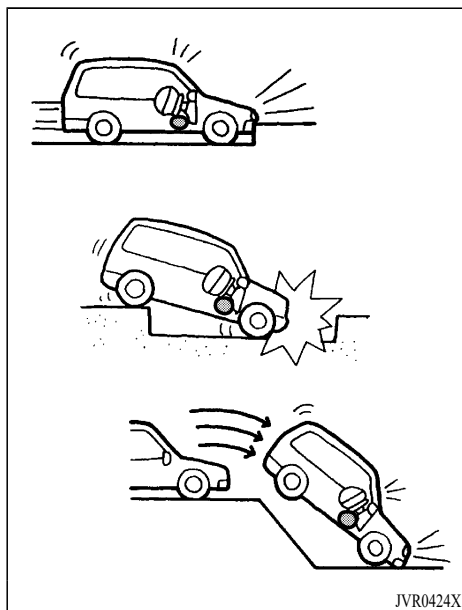

- Hitting a curb, pavement edge or hard surface at high speed
- Falling into a deep hole or ditch
- Landing hard on the ground after jumping

Front center airbag, front and second row seat side airbags and curtain airbags:

The front center airbag, front and second row seat side airbag and curtain airbag systems are designed to inflate in higher severity side collisions. Some examples are shown in the following illustrations.

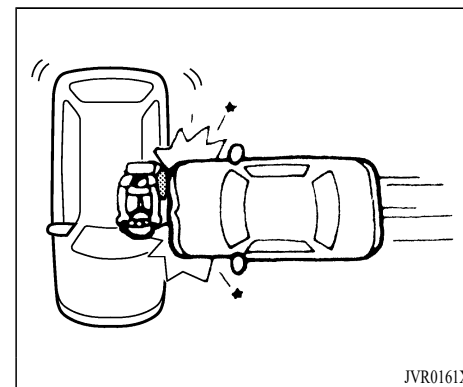

(Front center airbag and front and second row seat side airbag system)

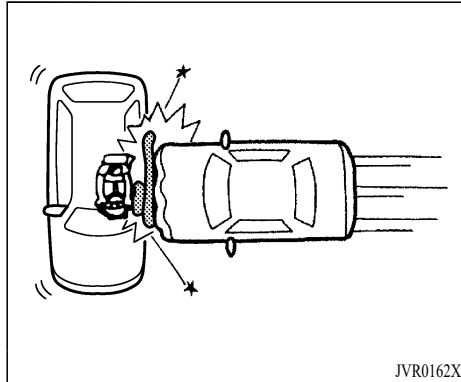

(Curtain airbag system)

- The front center airbag, front and second row seat side airbags and curtain airbags will deploy in the event of a side impact.

When the SRS airbag is unlikely to deploy

The SRS airbags may not deploy in cases where the impact is not forceful enough to inflate the SRS airbags.

For example, if the vehicle strikes an object, such as a parked vehicle or sign pole, which can move or deform on impact, the SRS airbags are unlikely to deploy.

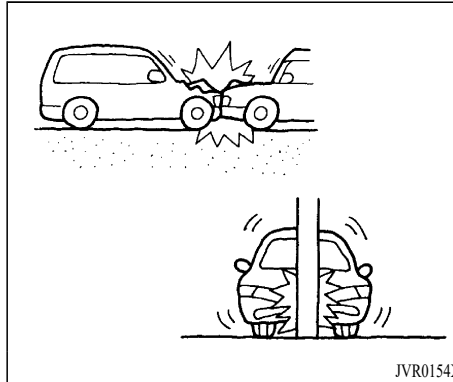

Driver and front passenger airbags and knee airbags:

- Striking a vehicle of the same class that is parked
- Crashing into a solid utility pole

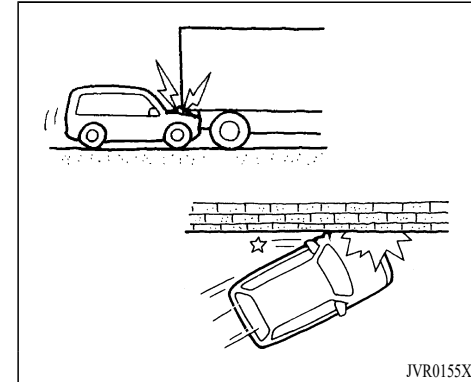

- Running under the liftgate of a truck
- A frontal offset impact to the guard rails

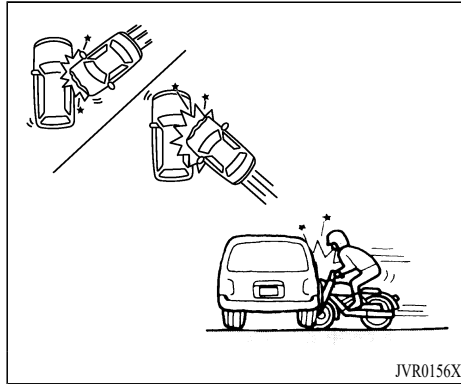

Front center airbag, front and second row seat side airbags and curtain airbags:

- A collision from the side at an angle
- A side impact with a two-wheeled vehicle

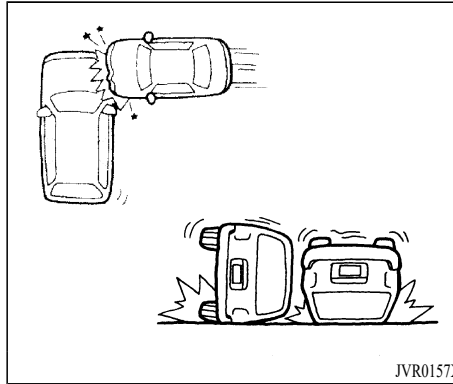

- A collision from the side impacting the vehicle engine room (luggage room)
- Vehicle rollover

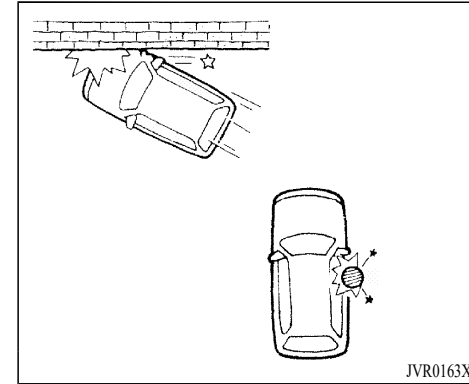

- A frontal offset impact to the guard rails
- A collision with a pole

When the SRS airbag will not deploy

Once the SRS airbag has inflated, the airbag module will not function again if your vehicle collides with another vehicle or an object.

Other examples where the SRS airbag will not deploy are shown in the following illustrations.

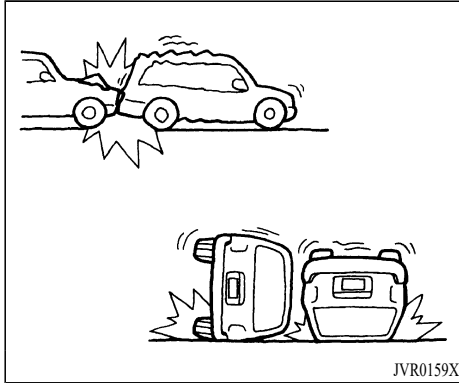

Driver and front passenger airbags and knee airbags:

- A collision from the side or rear
- Vehicle rollover

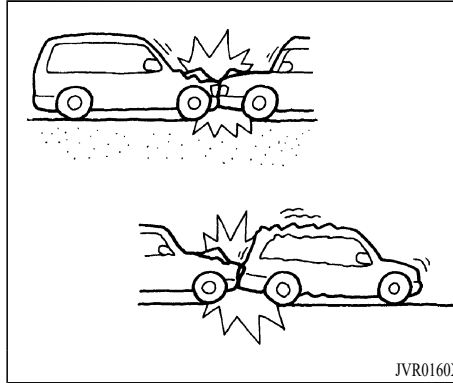

Front center airbag, front and second row seat side airbags and curtain airbags:

- A frontal collision with a parked or moving vehicle
- A rear collision

SEAT BELTS WITH PRETENSIONERS (front and second row outboard seats)

WARNING

- The pretensioners cannot be reused after activation. They must be replaced together with the retractor and buckle as a unit.
- If the vehicle becomes involved in a collision but a pretensioner is not activated, be sure to have the pretensioner system checked and, if necessary, repaired. It is recommended you visit an authorized Mitsubishi Motors dealer for this service.
- No unauthorized changes should be made to any components or wiring of the pretensioner system. This is to prevent damage to or accidental activation of the pretensioners. Tampering with the pretensioner system may result in serious personal injury.
- It is recommended you visit an authorized Mitsubishi Motors dealer for work on and around the pretensioner system. It is also recommended you visit an authorized Mitsubishi Motors dealer for installation of electrical equipment. Unauthorized electrical test equipment and probing devices should not be used on the pretensioner system.

- **If you need to dispose of a pretensioner or scrap the vehicle, it is recommended you visit an authorized Mitsubishi Motors dealer for this service. Correct pretensioner disposal procedures are set forth in the appropriate Mitsubishi Motors Service Manual. Incorrect disposal procedures could cause personal injury.**

The pretensioner system may activate with the airbag system in certain types of collisions. Working with the seat belt retractor, it helps tighten the seat belt when the vehicle becomes involved in certain types of collisions, helping to restrain front and second row outboard seat occupants.

The pretensioner is encased with the seat belt retractor. These seat belts are used the same way as conventional seat belts.

When a pretensioner activates, smoke is released and a loud noise may be heard. The smoke is not harmful and does not indicate a fire. Care should be taken not to inhale it, as it may cause irritation and choking. Those with a history of a breathing condition should get fresh air promptly.

After pretensioner activation, load limiters allow the seat belt to release webbing (if necessary) to reduce forces against the chest.

The SRS airbag warning light  is used to

indicate malfunctions in the pretensioner system. See “SRS airbag warning light” (P.1-71). If the operation of the SRS airbag warning light indicates there is a malfunction, have the system checked. It is recommended you visit an authorized Mitsubishi Motors dealer for this service.

When selling your vehicle, we request that you inform the buyer about the pretensioner system and guide the buyer to the appropriate sections in this Owner’s Manual.

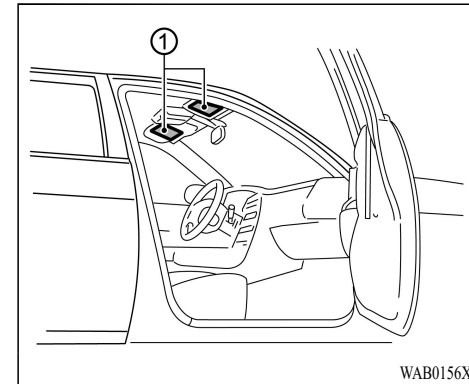

AIRBAG WARNING LABELS

Warning labels about the front airbag system are placed in the vehicle as shown in the illustration.

① SRS airbag

The warning labels are located on the surface of the sunvisors.



WARNING

Do not use a rear-facing child restraint or infant restraint on a seat protected by an airbag in front of it. If the airbag deploys, it may cause serious injury or death.



SRS AIRBAG WARNING LIGHT

The SRS airbag warning light, displaying  in the instrument panel, monitors the circuits for the airbag systems, pretensioners and all related wiring.

When the ignition switch is in the ON position, the SRS airbag warning light illuminates for about 7 seconds and then turns off. This means the system is operational.

If any of the following conditions occur, the airbag and/or pretensioner systems need servicing:

- The SRS airbag warning light remains on after approximately 7 seconds.
- The SRS airbag warning light flashes intermittently.
- The SRS airbag warning light does not come on at all.
- The SRS airbag warning light and/or the warning display comes on while driving.

Under these conditions, the airbag and/or pretensioner systems may not operate properly. They must be checked and repaired. It is recommended you visit an authorized Mitsubishi Motors dealer for this service.

WARNING

If the SRS airbag warning light is on, it could mean that the front airbag, knee airbag, side airbag, curtain airbag and/or pretensioner systems will not operate in an accident. To help avoid injury to yourself or others, have your vehicle checked as soon as possible. It is recommended you visit an authorized Mitsubishi Motors dealer for this service.

REPAIR AND REPLACEMENT PROCEDURE

The front airbags, knee airbags, side airbags, curtain airbags and pretensioners are designed to activate on a one-time-only basis. As a reminder, unless it is damaged, the SRS airbag warning light will remain illuminated after inflation has occurred. These systems should be repaired and/or replaced as soon as possible. It is recommended you visit an authorized Mitsubishi Motors dealer for this service.

When maintenance work is required on the vehicle, the front airbags, knee airbags, side airbags, curtain airbags and pretensioners and related parts should be pointed out to the person performing the maintenance. The ignition switch should always be in the LOCK position when working under the hood or inside the vehicle.

WARNING

- **Once a front airbag, knee airbag, side airbag or curtain airbag has inflated, the airbag module will not function again and must be replaced. Additionally, the activated pretensioners must also be replaced. The airbag module and pretensioner should be replaced. It is recommended you visit an authorized Mitsubishi Motors**

dealer for this service. However, the airbag modules and pretensioner system cannot be repaired.

- The front airbag, knee airbag, side airbag and curtain airbag systems, and pretensioner system should be inspected if there is any damage to the front end or side portion of the vehicle. It is recommended you visit an authorized Mitsubishi Motors dealer for this service.
- If you need to dispose of a airbag or pretensioner or scrap the vehicle, it is recommended you visit an authorized Mitsubishi Motors dealer. Correct airbag and pretensioner system disposal procedures are set forth in the appropriate Mitsubishi Motors Service Manual. Incorrect disposal procedures could cause personal injury.
- If there is an impact to your vehicle from any direction, your Occupant Classification Sensor (OCS) should be checked to verify it is still functioning correctly. It is recommended that you visit an authorized Mitsubishi Motors dealer for this service. The OCS should be checked even if no airbags deploy as a result of the impact. Failure to verify proper OCS function may result in an improper airbag deployment resulting in injury or death.
- When you transfer ownership of the vehicle to another person, we urge you to alert the new owner that it is equipped

with the SRS and refer that owner to the applicable sections in this owner's manual.

- If you decide to junk or scrap your vehicle, we urge you to first take it to an authorized Mitsubishi Motors dealer so that the SRS can be made safe for disposal.
- If any of the following parts needs to be modified for use by a handicapped person, the advanced airbag system will be greatly affected. Please consult an authorized Mitsubishi Motors dealer.
 - Driver's seat
 - Front passenger seat
 - Front seat belt
 - Steering wheel
 - Instrument panel

[For vehicles sold in U.S.A.]

To contact Mitsubishi Motors North America, Inc. call 1-888-648-7820 or write to:

Mitsubishi Motors North America, Inc.
Customer Relations Department
P.O. Box 689040
Franklin, TN 37068

[For vehicles sold in Canada]

To contact Mitsubishi Motor Sales of Canada, Inc.

call 1-888-576-4878 or write to:

Mitsubishi Motor Sales of Canada, Inc. Customer Relations Department

P.O. Box 41009
4141 Dixie Road
Mississauga, ON L4W 5C9

[For vehicles sold in Puerto Rico]

To contact Mitsubishi Motor Sales of Caribbean, Inc.

call 1-787-251-8715 or write to:

Mitsubishi Motor Sales of Caribbean, Inc.
Customer Service Department
P.O. Box 192216
SAN JUAN PR 00919-2216

[For vehicles sold in Guam]

To contact Triple J Enterprises Inc.

call (671) 649-3673 or write to:

Triple J Enterprises, Inc.
P.O. Box 6066
TAMUNING
GUAM 96931

[For vehicles sold in Saipan]

**To contact Triple J Motors
call (670) 234-7133 or write to:**

Triple J Motors

P.O. Box 500487

SAIPAN, MP96950-0487

[For vehicles sold in American Samoa]

**To contact Pacific Marketing Inc.
call 684 (699) 9140 or write to:**

Pacific Marketing, Inc.

P.O. Box 698

PAGO PAGO,

AMERICAN SAMOA AS, 96799

MEMO

1-74 Safety — Seats, seat belts and supplemental restraint system

Condition:

[Edit: 2021/ 2/ 10 Model: DG-D]

2 Instruments and controls

Cockpit	2-3	Startup display	2-22
Instrument panel	2-4	Personal Display (model with full-screen display)	2-22
Meters and gauges	2-5	Settings	2-23
Model with Combination meter cluster / Multi- information display (Type 1)	2-5	Multi-information display warnings and indicators	2-33
Model with full digital driver display (Type 2)	2-6	Trip computer	2-41
Changing the meter screen view (model with type 2 display)	2-7	Clock and outside air temperature	2-43
Speedometer and odometer	2-8	Head-Up Display (HUD) (if so equipped)	2-43
Tachometer	2-9	How to use the HUD	2-44
Engine coolant temperature gauge	2-9	Driver assistance/Navigation/Traffic Sign/Audio/TEL/SMS linking	2-45
Fuel gauge	2-10	Security systems	2-46
Instrument brightness control	2-11	Anti-theft alarm system	2-46
Continuously Variable Transmission (CVT) position indicator	2-11	Anti-theft engine immobilizer	2-47
Warning lights, indicator lights and audible reminders	2-12	Wiper and washer switch	2-48
Checking lights	2-13	Windshield wiper and washer operation	2-49
Warning/indicator lights (red)	2-13	Rain-sensing auto wiper system (if so equipped)	2-49
Warning/indicator lights (yellow)	2-16	Rear window wiper and washer switch	2-51
Warning/indicator lights (other)	2-19	Electric rear window and door mirror defroster switch	2-52
Audible reminders	2-20	Wiper deicer switch (if so equipped)	2-53
Multi-information display	2-21	Headlight and turn signal switch	2-53
Changing the meter screen view (model with full-screen display)	2-21	Headlight switch	2-54
How to use the multi-information display	2-21	Headlight cleaner (if so equipped)	2-58

Turn signal switch	2-59	Sunglasses holder	2-71
Fog light switch (if so equipped)	2-59	Card holder	2-71
Horn	2-60	Luggage hooks	2-72
Heated steering wheel (if so equipped)	2-60	Coat hooks	2-72
Heated seats (if so equipped)	2-61	Tonneau cover (if so equipped)	2-73
Operation with switch	2-62	Roof rail (if so equipped)	2-74
Rear Seat Alert	2-62	Windows	2-75
Power outlet	2-63	Power windows	2-75
USB (Universal Serial Bus) charging outlet (if so equipped)	2-64	Sunroof (if so equipped)	2-78
Wireless charger (if so equipped)	2-64	Power panoramic sunroof and sunshade	2-78
Emergency call system (e-CALL) (if so equipped)	2-67	Interior lights	2-80
Emergency support	2-67	Interior light switch	2-80
Storage	2-68	Map lights	2-80
Cup holders	2-68	Dome lights (if so equipped)	2-81
Soft bottle holders	2-69	Rear personal lights (if so equipped)	2-81
Luggage compartment	2-69	Vanity mirror light	2-81
Glove box	2-70	Cargo room light	2-82
Console box	2-70	Liftgate light	2-82

COCKPIT

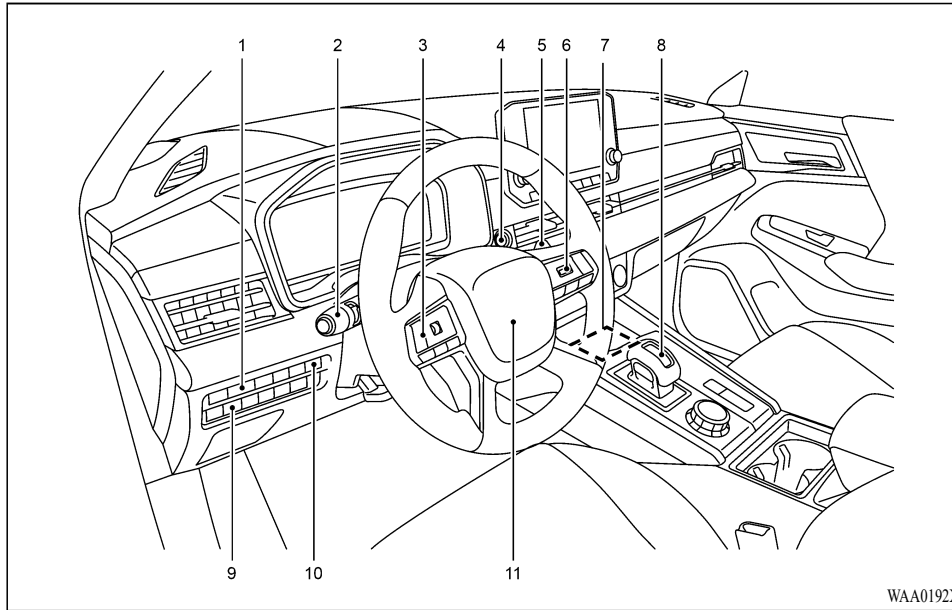

- | | |
|---|--|
| 1. Instrument brightness control | 4. Push-button ignition switch |
| 2. Headlight and turn signal switch/Fog light switch* | 5. Wiper and washer switch |
| 3. Steering wheel remote control switches (left side) | 6. Steering wheel remote control switches (right side) |
| — Audio control** | — Cruise control* |
| — Multi-information display control | — Adaptive Cruise Control System (ACC)* |
| | — MI-PILOT Assist* |

- Bluetooth® Hands-Free Phone System**
 - Voice Recognition system switch**
7. Wireless charger*
 8. Shift lever
 - Continuously Variable Transmission (CVT)
 9. Head-Up Display (HUD) switch*
 10. Power liftgate switch*
 11. Steering wheel
 - Horn
- *: if so equipped
 **: See the separate Smartphone-link Display Audio (SDA) Owner's Manual.

INSTRUMENT PANEL

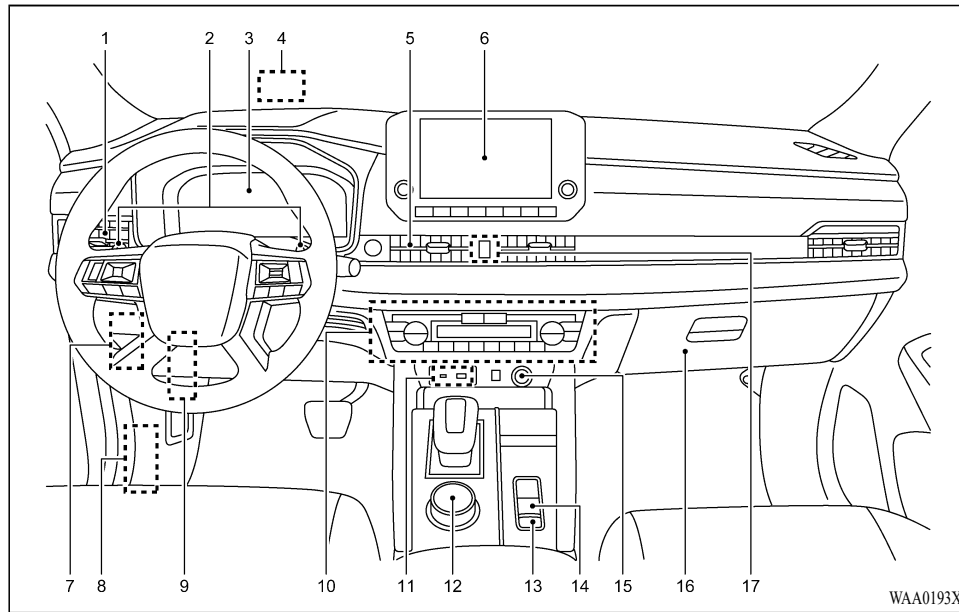

- | | |
|--|--|
| 1. Side ventilator | — Multi Around Monitor* |
| 2. Steering wheel paddle shifter | — Bluetooth® Hands-Free Phone System** |
| 3. Meters and gauges/Clock | |
| 4. Head-Up Display (HUD)* | |
| 5. Center ventilator | |
| 6. Audio system** or navigation system** | |
| — Rearview camera* | |
| 7. Fuse box cover | |
| 8. Hood release handle | |
| 9. Steering wheel lock lever | |
| 10. Heater/air conditioner control | |
| — Defroster switch | |

- Windshield deicer switch*
 - Heated seat switch*
 - Heated steering wheel switch*
11. USB (Universal Serial Bus) input terminal**
 12. Drive mode selector
 - Hill Descent Control switch
 13. Brake Auto Hold switch
 14. Parking brake switch
 15. Power outlet
 16. Glove box
 17. Hazard indicator flasher switch
- *: if so equipped
 **: See the separate Smartphone-link Display Audio (SDA) Owner's Manual.

2-4 Instruments and controls

METERS AND GAUGES

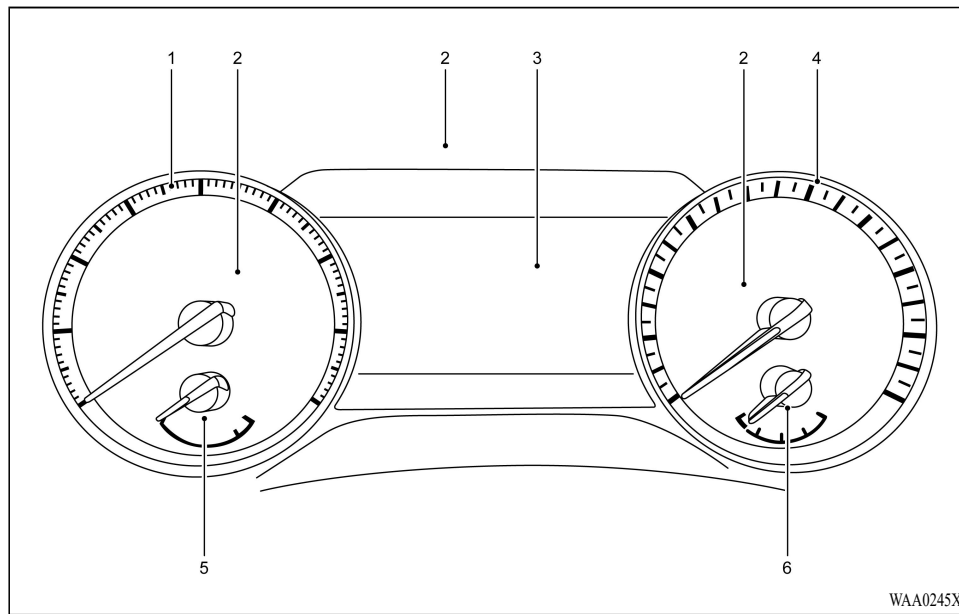

1. Tachometer
2. Warning/indicator lights
3. Multi-information display
 - Distance to empty/Odometer
4. Speedometer
5. Engine coolant temperature gauge
6. Fuel gauge

MODEL WITH COMBINATION METER CLUSTER / MULTI- INFORMATION DISPLAY (Type 1)

The needle indicators may move slightly after the ignition switch is placed in the OFF or LOCK position. This is not a malfunction.

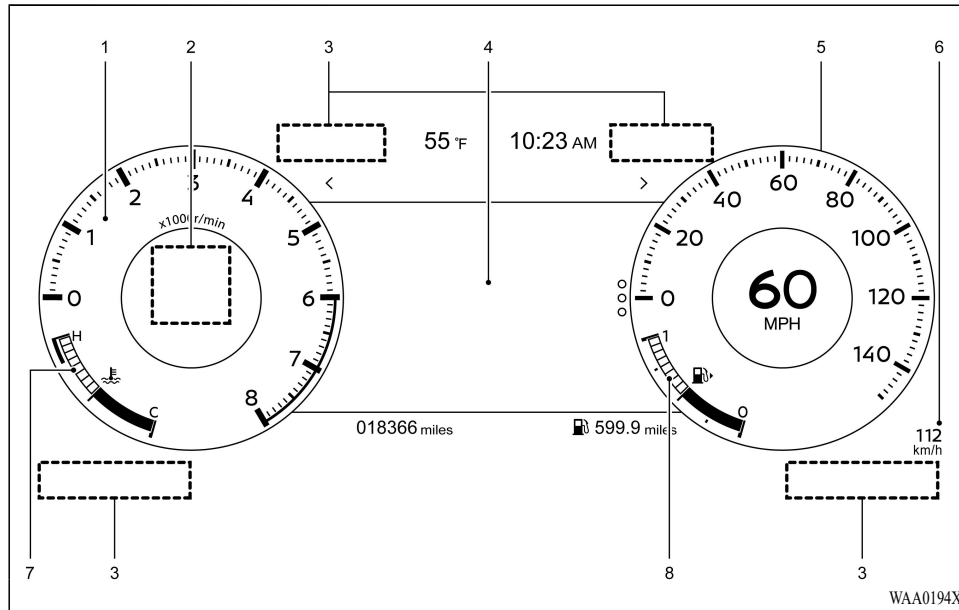

- | | |
|------------------------------|-------------------------------------|
| 1. Tachometer | 7. Engine coolant temperature gauge |
| 2. Personal display | 8. Fuel gauge |
| 3. Warning/indicator lights | |
| 4. Multi-information display | |
| — Distance to empty/Odometer | |
| 5. Speedometer | |
| 6. Secondary speedometer | |

2-6 Instruments and controls

MODEL WITH FULL DIGITAL DRIVER DISPLAY (Type 2)

CAUTION

- For cleaning, use a soft cloth, dampened with water. Never use a rough cloth, alcohol, benzene, thinner or any kind of solvent or paper towel with a chemical cleaning agent. They will scratch or cause discoloration to the lens.
- Do not spray any liquid such as water on the meter lens. Spraying liquid may cause the system to malfunction.

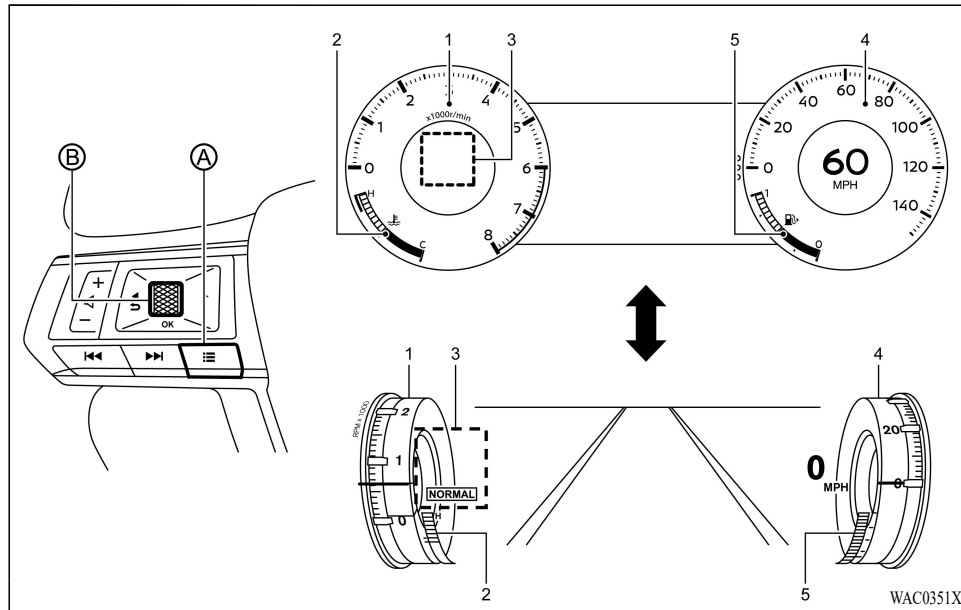

1. Tachometer
2. Engine coolant temperature gauge
3. Personal Display
4. Speedometer
5. Fuel gauge

CHANGING THE METER SCREEN VIEW (model with type 2 display)

For the model with full-screen display, the meter screen view can be changed to expand the multi-information display area.

To change the meter screen view:

1. Push the control switch (A) on the left side of the steering wheel.
2. "Short Cut Menu" appears on the multi-information display area.
3. Select "Change Meter View" by rotating the scroll dial (B) and push scroll dial (A) to confirm.

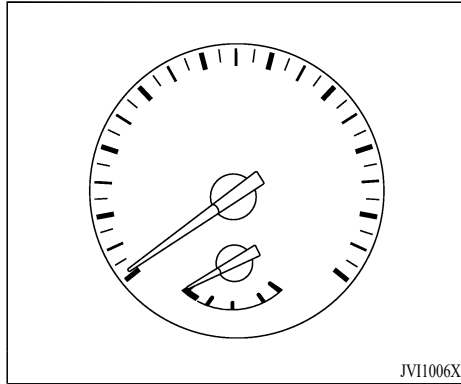

Example

SPEEDOMETER AND ODOMETER

Speedometer

The speedometer indicates vehicle speed in miles per hour (MPH) and kilometers per hour (km/h).

Secondary speedometer (models with type 2 meter)

The secondary speedometer indicates vehicle speed in kilometers per hour (km/h) and miles per hour (MPH).

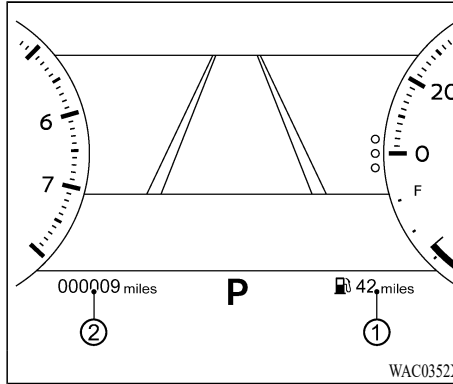

Example

Distance to empty (dte — km or mile)/Odometer

Distance to empty (dte — km or mile):

The distance to empty (dte) ① provides you with an estimation of the distance that can be driven before refueling. The dte is constantly being calculated, based on the amount of fuel in the fuel tank and the actual fuel consumption.

The display is updated every 30 seconds.

The dte mode includes a low range warning feature. If the fuel level is low, the warning is displayed on the screen.

When the fuel level drops even lower, the dte

display will change to “_____”.

- If the amount of fuel added is small, the display just before the ignition switch is placed in the “OFF” position may continue to be displayed.
- When driving uphill or rounding curves, the fuel in the tank shifts, which may momentarily change the display.

Odometer:

The odometer ② is displayed in the multi-information display when the ignition switch is in the ON position.

The odometer displays the total distance the vehicle has been driven.

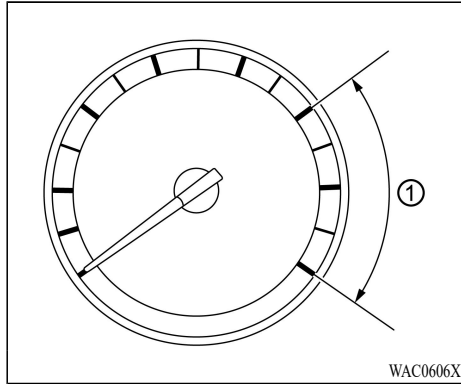

Example

TACHOMETER

The tachometer indicates engine speed in revolutions per minute (RPM). **Do not rev the engine into the red zone ①.**

CAUTION

When engine speed approaches the red zone, shift to a higher gear or reduce engine speed. Operating the engine in the red zone may cause serious engine damage.

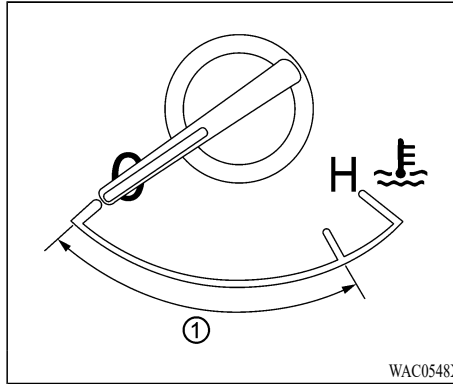

Type 1

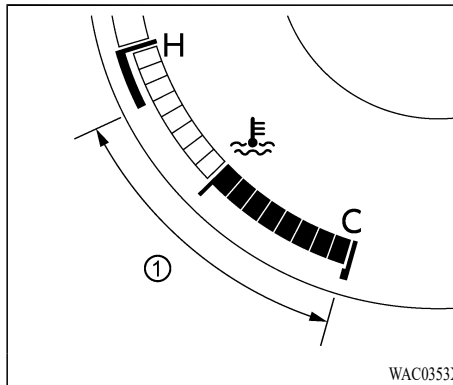

Type 2

ENGINE COOLANT TEMPERATURE GAUGE

The engine coolant temperature gauge indicates the engine coolant temperature.

The engine coolant temperature is normal when the gauge points within the zone ① shown in the illustration.

The engine coolant temperature will vary with the outside air temperature and driving conditions.

CAUTION

- If the gauge indicates the engine coolant temperature is near the hot (H) end of the normal range, reduce vehicle speed to decrease the temperature.
- If the gauge is over the normal range, stop the vehicle as soon as safely possible and let the engine idle.
- If the engine is overheated, continued operation of the vehicle may seriously damage the engine. (See "If your vehicle overheats" (P.6-14) for immediate action required.)

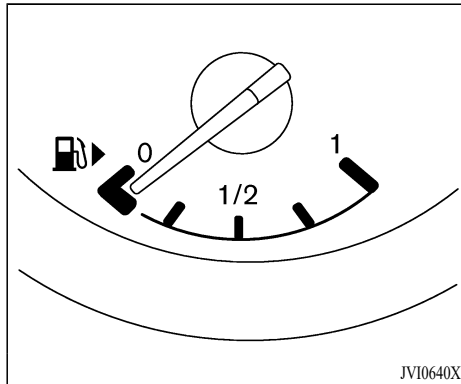

Type 1

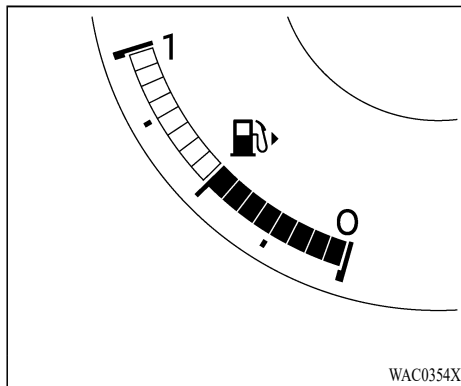

Type 2

FUEL GAUGE

The fuel gauge indicates the approximate fuel level in the tank when the ignition switch is in the ON position.

The gauge may move slightly during braking, turning, accelerating, or going up and down hills due to movement of fuel in the tank.

It may take several seconds to stabilize the display after refilling the tank.

The low fuel warning  appears on the multi-information display when the fuel level in the tank is getting low. Refuel as soon as it is convenient, preferably before the gauge reads 0 (empty).



The arrow, , indicates the location of the fuel filler door.

Refuel before the gauge reads the empty (0) position.

If fuel is added with the ignition switch is in the ON position, or the amount of the refueled fuel is small, the remaining fuel display may incorrectly indicate the fuel level.

There is a small reserve of fuel in the tank when the fuel gauge reads the empty (0) position.

CAUTION

- If the vehicle runs out of fuel, the  malfunction indicator light (MIL) may come on. Refuel as soon as possible. After a few driving trips, the  light should turn off. If the light remains on after a few driving trips, have the vehicle inspected. It is recommended you visit an authorized Mitsubishi Motors dealer for this service.
- For additional information, see “Malfunction Indicator Light (MIL)” (P.2-18).

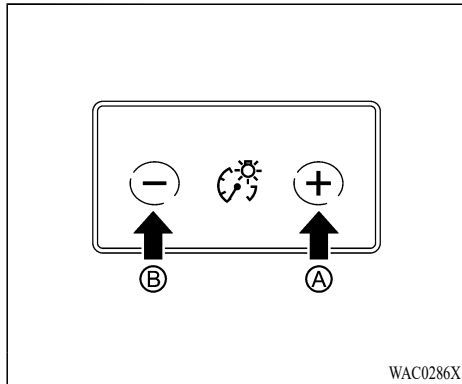

CONTINUOUSLY VARIABLE TRANSMISSION (CVT) POSITION INDICATOR

The Continuously Variable Transmission (CVT) position indicator indicates the shift lever position when the ignition switch is in the ON position.





























INSTRUMENT BRIGHTNESS CONTROL

The instrument brightness control switch can be operated when the ignition switch is in the ON position.

Push the + side of the switch Ⓐ to brighten the meter and instrument panel lights.







Push the - side of the switch Ⓑ to dim the lights.

WARNING LIGHTS, INDICATOR LIGHTS AND AUDIBLE REMINDERS









Warning/indicator lights (red)	Warning/indicator lights (yellow)	Warning/indicator lights (other)
 BRAKE	 Active stability control (ASC) warning light	 Automatic High Beam (AHB) indicator light
 Brake warning light (red)	 Active stability control (ASC) off indicator light	 Brake Auto Hold indicator light (white)
 Charge warning light	 ABS	 Brake Auto Hold indicator light (green)
 Electric shift control system warning light	 (ABS)	 Exterior light indicator
 PARK	 Forward Collision Mitigation System (FCM) OFF warning light	 Front fog light indicator light (if so equipped)
 Electric parking brake warning light	 Electric power steering warning light	 High beam indicator light
 Engine oil pressure warning light	 Electric parking brake warning light (yellow)	 Turn signal/hazard indicator lights
 Front seat belt warning light and chime	 Low tire pressure warning light	
 Hands OFF warning light (if so equipped)	 Malfunction Indicator Light (MIL)	
 Master warning light	 Master warning light	
 SRS airbag warning light	 Rear Automatic Emergency Braking (Rear AEB) system OFF warning light	

CHECKING LIGHTS

With all doors closed, apply the parking brake, fasten the seat belts and place the ignition switch in the ON position without starting the engine. The following lights (if so equipped) will come on:

, , BRAKE or  (red), PARK or ,  OFF,  OFF, .

The following lights (if so equipped) come on briefly and then go off:

, , , , ABS or , , BRAKE OIL  (red),  (yellow), .

If any light does not come on or operates in a way other than described, it may indicate a burned-out bulb and/or a system malfunction. It is recommended you have the system checked by an authorized Mitsubishi Motors dealer.

WARNING/INDICATOR LIGHTS (red)

See also “Multi-information display” (P.2-21).

or Brake warning light (red)

This light functions for the brake system.

Low brake fluid warning light:

When the ignition switch is placed in the ON position, the brake warning light illuminates, and then turns off. If the light illuminates while the engine is running, stop the vehicle and perform the following:

1. Check the brake fluid level. If brake fluid is necessary, add fluid and have the system checked. It is recommended you have this service performed by an authorized Mitsubishi Motors dealer. (See “Brake fluid” (P.8-9).)
2. If the brake fluid level is correct, have the warning system checked. It is recommended you have this service performed by an authorized Mitsubishi Motors dealer.

Anti-lock Braking System (ABS) warning indicator:

When the parking brake is released and the brake fluid level is sufficient, if both the brake warning light and the Anti-lock Braking System (ABS) warning light illuminate, it may indicate the ABS is not functioning properly. Have the brake system checked, and if necessary re-

paired. It is recommended you visit an authorized Mitsubishi Motors dealer for this service. (See “Anti-lock Braking System (ABS) warning light” (P.2-16).)

WARNING

- Your brake system may not be working properly if the warning light is on. Driving could be dangerous. If you judge it to be safe, drive carefully to the nearest service station for repairs. Otherwise, have your vehicle towed because driving it could be dangerous.
- Pressing the brake pedal with the engine stopped and/or low brake fluid level may increase your stopping distance and braking will require greater pedal effort as well as pedal travel.
- If the brake fluid level is below the minimum or MIN mark on the brake fluid reservoir, do not drive until the brake system has been checked. It is recommended you visit an authorized Mitsubishi Motors dealer for this service.

Charge warning light

When the ignition switch is in the ON position, the charge warning light illuminates and then turns off.

If the light illuminates while the engine is running, it may indicate the charging system is not functioning properly. Turn the engine off and check the alternator belt. If the belt is loose, broken, missing or if the light remains on, have your vehicle serviced immediately. It is recommended you visit an authorized Mitsubishi Motors dealer for this service.

CAUTION

Do not continue driving if the alternator belt is loose, broken or missing.

Electric shift control system warning light

When the ignition switch is in the ON position, the electric shift control system warning light illuminates, and then turns off. This indicates the electric shift control system is operational.

The electric shift control system warning light illuminates when a malfunction occurs in the electric shift control system. When the master

warning light illuminates, the chime sounds and the following message is displayed in the multi-information display: “When parked apply parking brake”.

When the ignition switch is placed in the OFF position, the chime sounds continuously. Ensure the parking brake is applied.

Have the system checked by an authorized Mitsubishi Motors dealer or a repair facility of your choice immediately.

or **PARK** **Electric parking brake warning light**

The electric parking brake warning light indicates that the electric parking brake system is operating.

When the ignition switch is placed in the ON position, the electric parking brake warning light illuminates. When the engine is started and the parking brake is released, the warning light turns off.

If the parking brake is not fully released, the electric parking brake warning light remains on. Be sure that the electric parking brake warning light has turned off before driving. (See “Parking brake” (P.5-23).)

If the electric parking brake warning light illuminates or flashes while the electric parking brake warning light  (yellow) illuminates, it

may indicate that the electric parking brake system is not functioning properly. Have the system checked, and if necessary repaired. It is recommended you visit an authorized Mitsubishi Motors dealer for this service.

Engine oil pressure warning light

This light warns of low engine oil pressure. When the ignition switch is in the “ON” position, the engine oil pressure warning light illuminates. After starting the engine, the engine oil pressure warning light turns off. This indicates that the oil pressure sensors in the engine are operational.

If the engine oil pressure warning light illuminates or blinks while the engine is running, it may indicate that the engine oil pressure is low.

Stop the vehicle safely as soon as possible. Stop the engine immediately and call an authorized Mitsubishi Motors dealer.

CAUTION

- **Running the engine with the engine oil pressure warning light illuminated could cause serious damage to the engine.**

- The engine oil pressure warning light is not designed to indicate a low oil level. The oil level should be checked using the dipstick. (See “Engine oil” (P.8-6).)

Front seat belt warning light and chime

The light and chime remind you to fasten the seat belts.

The light illuminates whenever the ignition switch is placed in the ON position, and will remain illuminated until the seat belts are fastened.

The seat belt warning light for the front passenger will illuminate if the seat belt is not fastened when the front passenger's seat is occupied.

When the vehicle speed exceeds 10 MPH (15 km/h), the light will continue to blink for about 95 seconds until the driver's seat belt is fastened and the light will blink unless the front passenger's seat belts is securely fastened and the chime will sound for about 95 seconds unless the front passenger's seat belt is securely fastened.

When the ignition switch is placed in the ON position, the chime will sound for about 6 seconds unless the driver's seat belt is securely

fastened.

For additional information, refer to “Seat belt warning light and chime” (P.1-19).

Hands OFF warning light (if so equipped)

When the Lane Keep Assist (LKA) is activated, it monitors the driver's steering wheel operation. If the steering wheel is not operated or the driver takes his/her hands off the steering wheel for a period of time, the warning light illuminates on the meter panel. If the driver does not operate the steering wheel after the warning light has been illuminated, an audible alert sounds and the warning flashes in the multi-information display, followed by a quick brake application to request the driver to take control of the vehicle again. (See “Lane Keep Assist (LKA)” (P.5-117).)

Master warning light (red)

When the ignition switch is in the ON position, the master warning light (red) illuminates if a warning message appears in the multi-information display.

See “Multi-information display” (P.2-21).

SRS airbag warning light

After placing the ignition switch in the ON position, the SRS airbag warning light will illuminate. The SRS airbag warning light will turn off after about 7 seconds if the supplemental front airbag and supplemental side airbag, curtain airbag systems and/or pretensioner seat belt are operational.

If any of the following conditions occur, the front airbag, side airbag, curtain airbag and pretensioner systems need servicing.

- The SRS airbag warning light remains on after approximately 7 seconds.
- The SRS airbag warning light flashes intermittently.
- The SRS airbag warning light does not illuminate at all.

It is recommended you visit an authorized Mitsubishi Motors dealer for these services.

Unless checked and repaired, the Supplemental Restraint Systems and/or the pretensioners may not function properly.

For additional information, see “Supplemental Restraint System (SRS)” (P.1-47).

WARNING

If the SRS airbag warning light is on, it could mean that the front airbag, side airbag, curtain airbag and/or pretensioner systems will not operate in an accident. To help avoid injury to yourself or others, have your vehicle checked. It is recommended you visit an authorized Mitsubishi Motors dealer for this service.

WARNING/INDICATOR LIGHTS (yellow)

See also “Multi-information display” (P.2-21).

Active stability control (ASC) warning light

When the ignition switch is in the ON position, the Active stability control (ASC) warning light illuminates and then turns off.

The light will blink when the Active stability control (ASC) or the traction control system is operating, thus alerting the driver that the vehicle is nearing its traction limits. The road surface may be slippery.

If the ASC warning light illuminates while the ASC is on, this light alerts the driver to the fact that the ASC's fail-safe mode is operating, for example the ASC may not be functioning

properly. Have the system checked. It is recommended you visit an authorized Mitsubishi Motors dealer for this service. If a malfunction occurs in the system, the ASC function will be canceled but the vehicle is still driveable. For additional information, see “Active stability control (ASC)” (P.5-159) of this manual.

Active stability control (ASC) off indicator light

When the ignition switch is in the ON position, the Active stability control (ASC) off indicator light illuminates and then turns off.

The light comes on when the Active stability control (ASC) is turned OFF. This indicates that the ASC and traction control system are not operating.

ABS or Anti-lock Braking System (ABS) warning light

When the ignition switch is in the ON position, the Anti-lock Braking System (ABS) warning light illuminates and then turns off. This indicates the ABS is operational.

If the ABS warning light illuminates while the engine is running, or while driving, it may indicate the ABS is not functioning properly. Have the system checked. It is recommended

you visit an authorized Mitsubishi Motors dealer for this service.

If an ABS malfunction occurs, the anti-lock function is turned off. The brake system then operates normally, but without anti-lock assistance. (See “Brake system” (P.5-156).)

Forward Collision Mitigation System (FCM) OFF warning light

When the ignition switch is in the ON position, the FCM system OFF warning light illuminates. After starting the engine, the warning light turns off.

This light illuminates when the FCM system is set to OFF on the multi-information display.

If the light illuminates when the FCM system is ON, it may indicate that the system is unavailable. See “Forward Collision Mitigation System (FCM)” (P.5-126) or “Predictive Forward Collision Warning (PFCW)” (P.5-135).

Electric power steering warning light

When the ignition switch is in the ON position, the electric power steering warning light illuminates. After starting the engine, the electric power steering warning light turns off. This indicates the electric power steering is operational.

If the electric power steering warning light illuminates while the engine is running, it may indicate the electric power steering is not functioning properly and may need servicing. Have the system checked. It is recommended that you visit an authorized Mitsubishi Motors dealer for this service.

When the electric power steering warning light illuminates with the engine running, the power assist to the steering will cease operation but you will still have control of the vehicle. At this time, greater steering efforts are required to operate the steering wheel, especially in sharp turns and at low speeds.

(See “Electric power steering” (P.5-156).)

Electric parking brake warning light (yellow)

When the ignition switch is in the ON position, the electronic parking brake warning light illuminates and then turns off.

The electric parking brake warning light functions for the electric parking brake system. If the warning light illuminates, it may indicate that the electric parking brake system is not functioning properly. Have the brake system checked, and, if necessary, repaired. It is recommended that you visit an authorized Mitsubishi Motors dealer for this service.

Low tire pressure warning light

Your vehicle is equipped with a Tire Pressure Monitoring System (TPMS) that monitors the tire pressure of all tires.

The low tire pressure warning light warns of low tire pressure or indicates that the TPMS is not functioning properly.

After the ignition switch is placed in the ON position, this light illuminates for about 1 second and turns off.

Low tire pressure warning:

If the vehicle is being driven with low tire pressure, the warning light will illuminate. The “Tire Pressure Low - Add Air”/“Tire Pressure Low - Check Cold Tire” warning also appears in the multi-information display.

When the low tire pressure warning light illuminates, you should stop and adjust the tire pressure to the recommended COLD tire pressure shown on the Tire and Loading Information placard. The low tire pressure warning light does not automatically turn off when the tire pressure is adjusted. After the tire is inflated to the recommended pressure, the vehicle must be driven at speeds above 16 MPH (25 km/h) to activate the TPMS and turn off the low tire pressure warning light. Use a tire pressure gauge to check the tire pressure.

The “Tire Pressure Low - Add Air”/“Tire Pressure Low - Check Cold Tire” warning is active as long as the low tire pressure warning light remains illuminated.

For additional information, see “Multi-information display” (P.2-21), “Tire Pressure Monitoring System (TPMS)” (P.5-6) and “Tire Pressure Monitoring System (TPMS)” (P.6-3).

TPMS malfunction:

If the TPMS is not functioning properly, the low tire pressure warning light will flash for approximately 1 minute when the ignition switch is placed in the ON position. The light will remain on after the 1 minute. Have the system checked. It is recommended you visit an authorized Mitsubishi Motors dealer for this service. The “Tire Pressure Low - Add Air”/“Tire Pressure Low - Check Cold Tire” warning does not appear if the low tire pressure warning light illuminates to indicate a TPMS malfunction.

For additional information, see “Tire Pressure Monitoring System (TPMS)” (P.5-6).

WARNING

- If the light does not illuminate with the ignition switch placed in the ON position, have the vehicle checked. It is recom-

mended you visit an authorized Mitsubishi Motors dealer for this service as soon as possible.

- If the light illuminates while driving, avoid sudden steering maneuvers or abrupt braking, reduce vehicle speed, pull off the road to a safe location and stop the vehicle as soon as possible. Driving with under-inflated tires may permanently damage the tires and increase the likelihood of tire failure. Serious vehicle damage could occur and may lead to an accident and could result in serious personal injury. Check the tire pressure for all four tires. Adjust the tire pressure to the recommended COLD tire pressure shown on the Tire and Loading Information placard to turn the low tire pressure warning light OFF. If the light still illuminates while driving after adjusting the tire pressure, a tire may be flat or the TPMS may be malfunctioning. If you have a flat tire, repair it with the tire repair kit as soon as possible. If no tire is flat and all tires are properly inflated, it is recommended you consult an authorized Mitsubishi Motors dealer.
- If a wheel that not equipped with the TPMS is installed, the TPMS will not function and the low tire pressure warning light will flash for approximately 1 minute. The light will remain on after 1 minute. Have your tires replaced and/or TPMS system reset as soon as possible. It is

recommended you visit an authorized Mitsubishi Motors dealer for these services.

- Replacing tires with those not originally specified by Mitsubishi Motors could affect the proper operation of the TPMS.



CAUTION

- The TPMS is not a substitute for the regular tire pressure check. Be sure to check the tire pressure regularly.
- If the vehicle is being driven at speeds of less than 16 MPH (25 km/h), the TPMS may not operate correctly.
- Be sure to install the specified size of tires to the four wheels correctly.



Malfunction Indicator Light (MIL)

If the malfunction indicator light comes on steady or blinks while the engine is running, it may indicate a potential emission control and/or Continuously Variable Transmission (CVT) malfunction.

The malfunction indicator light may also illuminate steady if the vehicle runs out of fuel. Check to make sure that the vehicle has at least

3 US gallons (11.4 liters) of fuel in the fuel tank.

After a few driving trips, the  light should turn off if no other potential emission control system malfunction exists.

If this indicator light remains on for 20 seconds and then blinks for 10 seconds when the engine is not running, it indicates that the vehicle is not ready for an emission control system inspection/maintenance test. (See “Readiness for Inspection/Maintenance (I/M) test” (P.10-33).)

Operation:

The malfunction indicator light will come on in one of two ways:

- Malfunction indicator light on steady — An emission control system and/or CVT malfunction has been detected. It is recommended you visit an authorized Mitsubishi Motors dealer for this service. You do not need to have your vehicle towed to the dealer.
- Malfunction indicator light blinking — An engine misfire has been detected which may damage the emission control system. To reduce or avoid emission control system damage:
 - 1) Do not drive at speeds above 45 MPH (72 km/h).

- 2) Avoid hard acceleration or deceleration.
- 3) Avoid steep uphill grades.
- 4) If possible, reduce the amount of cargo being hauled or towed.

The malfunction indicator light may stop blinking and remain on.

Have the vehicle inspected. It is recommended you visit an authorized Mitsubishi Motors dealer for this service. You do not need to have your vehicle towed to the dealer.

CAUTION

Continued vehicle operation without having the emission control system and/or CVT system checked and repaired as necessary could lead to poor driveability, reduced fuel economy, and possible damage to the emission control system.

Master warning light (yellow)

When the ignition switch is in the ON position, the master warning light (yellow) illuminates if a warning message appears in the multi-information display.

See “Multi-information display” (P.2-21).



Rear Automatic Emergency Braking (Rear AEB) system OFF warning light

This light comes on when the ignition switch is placed in the ON position. It turns off after the engine is started.

This light illuminates when the Rear AEB system is turned off in the multi-information display.

If the light illuminates when the Rear AEB system is on, it may indicate that the system is unavailable. For additional information, see “Rear Automatic Emergency Braking (Rear AEB)” (P.5-146).

WARNING/INDICATOR LIGHTS (other)

See also “Multi-information display” (P.2-21).



Automatic High Beam (AHB) indicator light (if so equipped)

The Automatic High Beam (AHB) indicator light illuminates when the Automatic High Beam (AHB) system is turned on and it is operational. (See “Automatic High Beam (AHB)” (P.2-56).)



Brake Auto Hold indicator light (white)

The Brake Auto Hold indicator light (white) illuminates when the Brake Auto Hold system is on standby. (See “Brake Auto Hold” (P.5-25).)





Brake Auto Hold indicator light (green)

The Brake Auto Hold indicator light (green) illuminates while the Brake Auto Hold system is operating. (See “Brake Auto Hold” (P.5-25).)



Exterior light indicator

This indicator illuminates when the headlight switch is turned to the AUTO (if so equipped),  or  position and the front parking lights, tail lights, license plate lights or headlights are on. The indicator turns off when these lights are turned off.



Front fog light indicator light (if so equipped)

The front fog light indicator light illuminates when the front fog lights are on. (See “Fog light switch” (P.2-59).)

High beam indicator light



This light illuminates when the headlight high beam is on and goes out when the low beam is selected.

Turn signal/hazard indicator lights

The light flashes when the turn signal switch lever or hazard switch is turned on.

AUDIBLE REMINDERS

Light reminder chime

The light reminder chime will sound when the driver side door is opened with the headlight switch in the  or  position, and the ignition switch is in the OFF position.

Turn the light switch off when you leave the vehicle.

Driving aid chimes

An audible alert/chime may be heard if any of the following systems are active (if so equipped):

- Forward Collision Mitigation System (FCM)
- Predictive Forward Collision Warning (PFCW)

- Blind Spot Warning (BSW)
- Active Blind Spot Assist (ABSA)
- Rear Cross Traffic Alert (RCTA)
- Lane Departure Prevention (LDP)
- Lane Departure Warning (LDW)
- MI-PILOT Assist
- Rear Automatic Emergency Braking (Rear AEB)
- Parking sensor system

For additional information, refer to the “Starting and driving” section of this manual.

Door lock warning chime

When the chime sounds, be sure to check both the vehicle and the F.A.S.T.-key. See “Troubleshooting guide” (P.3-13).

Brake pad wear warning

The disc brake pads have audible wear warnings. When a brake pad requires replacement, it will make a high pitched scraping sound when the vehicle is in motion. This scraping sound will first occur only when the brake pedal is depressed. After more wear of the brake pad, the sound will always be heard even if the brake pedal is not depressed. Have the brakes checked as soon as possible if the warning sound is heard.

Parking brake reminder chime

The parking brake reminder chime will sound if the vehicle is driven at more than 2 MPH (4 km/h) with the parking brake applied. Stop the vehicle and release the parking brake.

MULTI-INFORMATION DISPLAY

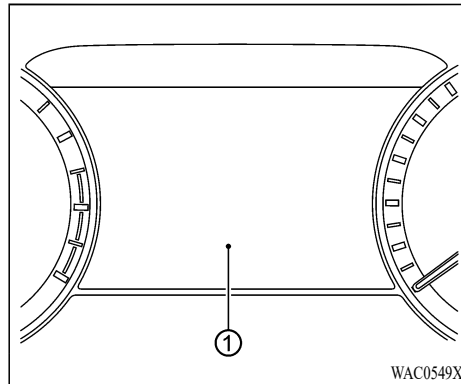

Example

The multi-information display ① is located as shown above, and it displays the warnings and information. The following items are also displayed if the vehicle is equipped with them:

- Tachometer
- Speedometer
- Vehicle settings
- Trip computer information
- Driver Assistance
- Cruise control system information
- MI-PILOT Assist
- F.A.S.T.-key operation information
- Audio information

- Navigation - turn by turn
- Indicators and warnings
- Tire pressure information
- Other information

CHANGING THE METER SCREEN VIEW (model with full-screen display)

For the model with full-screen display, the meter screen view can be changed to expand the multi-information display area. See “Changing the meter screen view (model with type 2 display)” (P.2-7) for how to transform.

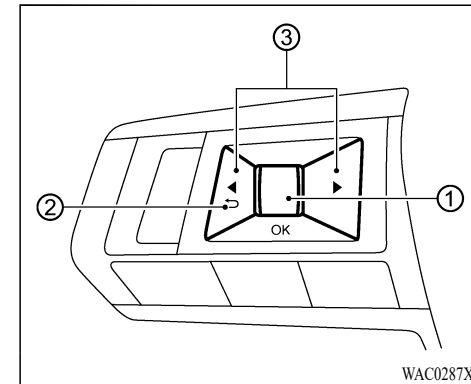

HOW TO USE THE MULTI-INFORMATION DISPLAY

The multi-information display can be changed using the buttons scroll dial ①, ⏪ ②, and ⏩ ③ located on the steering wheel.

- ① Scroll dial - rotate to navigate through the items and push to change or select an item in multi-information display
- ② ⏪ - go back to the previous menu
- ③ ⏩ - change from one display screen to the next (i.e. trip, Fuel economy)

STARTUP DISPLAY

When the ignition switch is placed in the ON position, the multi-information display may display the following screens if the vehicle is equipped with them:

- Home
- Drive Computer — Average Speed-Trip (Distance & Time)-Fuel Economy
- Compass or Navigation
- Audio
- MI-PILOT Assist
- Driving Aids
- Tire Pressures
- S-AWC
- Warnings
- Settings

Warnings will only display if there are any present. For more information on warnings and indicators, see “Multi-information display warnings and indicators” (P.2-33).

To control what items display in the multi-information display, see “Settings” (P.2-23).

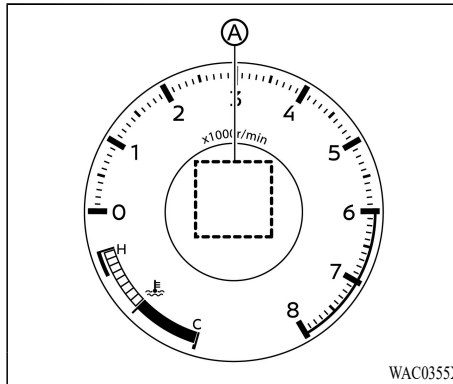

Example

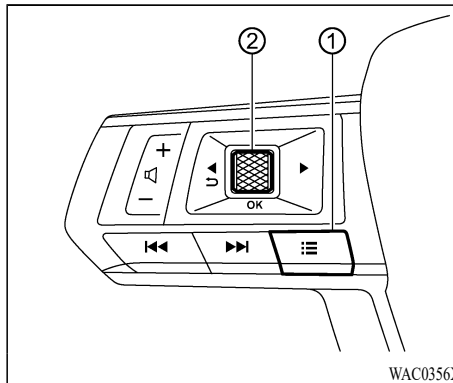

PERSONAL DISPLAY (model with full-screen display)

The personal display ② shows several information items. To select an information item:

1. Push the control switch ① on the left side of the steering wheel.
2. "Short Cut Menu" appears on the multi-information display area.
3. Select "Personal Display" by rotating the scroll dial ② and push the scroll dial to confirm.

The information item can be selected from below:

- Blank (nothing is displayed)
- Navigation (including compass)
- Time to Destination
- Fuel Economy
- Trip
- Gear position
- Average speed

The personal display ② will move when the meter screen view is changed. For additional information, refer to “Changing the meter screen view (model with type 2 display)” (P.2-7).

SETTINGS

The setting mode allows you to change the information displayed in the multi-information display. The following items are available if the vehicle is equipped with them:

- ASC Setting
- Driver Assistance
- Personal Display
- Head-Up Display
- ECO Mode Setting
- TPMS Setting
- Clock
- Vehicle Settings
- Maintenance
- Customize Display
- Units/Language
- Key- Linked Settings
- Factory Reset

ASC Setting

To change the setting, use the scroll dial to select and push it.

- System
This allows you to turn the Active stability control (ASC) ON or OFF. By default the ASC will be turned ON. If the ASC is turned off, the ASC OFF indicator light will illuminate.

NOTE:

The vehicle should be driven with the Active stability control (ASC) ON for most driving conditions. (See “Active stability control (ASC)” (P.5-159).)

Driver Assistance

To change the status, warnings or turn on or off any of the systems/warnings displayed in the “Driver Assistance” menu, use the scroll dial to select and change a menu item. The displayed menu items vary depending on the vehicle’s equipment.

- Steering Assist
- Lane
- Blind Spot
- Emergency Brake
- Traffic Sign
- Speed Adjust by Route
- Spd.Limit Assist
- Parking sensors
- Rear Cross Traffic Alert
- Driver Attention Alert
- Timer Alert
- Low Temp. Alert

Steering Assist:

- Allows user to turn the Lane Keep Assist (LKA) ON/OFF.

(See “MI-PILOT Assist” (P.5-90).)

Lane:

- Warning (LDW)
Allows user to turn the Lane Departure Warning (LDW) system ON/OFF.
- Prevention (LDP)
Allows user to turn the Lane Departure Prevention (LDP) system ON/OFF.

(See “Lane Departure Warning (LDW)” (P.5-33) and “Lane Departure Prevention (LDP)” (P.5-38).)

Blind Spot:

- Warning (BSW)
Allows user to turn the Blind Spot Warning (BSW) system ON/OFF.
- Active Assist (ABSA)
Allows user to turn the Active Blind Spot Assist (ABSA) system ON/OFF.

(See “Blind Spot Warning (BSW)” (P.5-43) and “Active Blind Spot Assist (ABSA)” (P.5-51).)

Emergency Brake:

Models without Rear Automatic Emergency Braking (Rear AEB) :

Allows user to turn the Forward Collision Mitigation System (FCM) system and Predictive Forward Collision Warning (PFCW) system ON/OFF.

Models with Rear Automatic Emergency Braking (Rear AEB) :

Allows user to turn the Forward Collision Mitigation System (FCM) system and Predictive Forward Collision Warning (PFCW) system ON/OFF

- Front
Allows user to turn the Forward Collision Mitigation System (FCM) system and Predictive Forward Collision Warning (PFCW) system ON/OFF
- Rear
Allows user to turn the Rear Automatic Emergency Braking (Rear AEB) system ON/OFF.

(See “Forward Collision Mitigation System (FCM)” (P.5-126), “Predictive Forward Collision Warning (PFCW)” (P.5-135) and “Rear Automatic Emergency Braking (Rear AEB)” (P.5-146).)

Traffic Sign:

This menu allows the customer to turn the Traffic Sign Recognition ON/OFF. (See “Traffic Sign Recognition (TSR)” (P.5-30).)

Speed Adjust by Route:

Allows user to turn the Speed Adjust by Route (MI-PILOT Assist with Navi-link) function ON/OFF. (See “Speed Adjust by Route - a feature of

MI-PILOT Assist with Navi-link” (P.5-110).)

Spd. Limit Assist:

Allows user to customize the Speed Limit Assist (MI-PILOT Assist with Navi-link) options.

- OFF
- Manual
- Auto

(See “Speed Limit Assist - a feature of MI-PILOT Assist with Navi-link” (P.5-108).)

Parking sensors:

To change the status or turn on or off any of the systems displayed in the “Parking sensors” menu, use the scroll dial ① to select and change a menu item:

- Moving Object
Push the scroll dial ① to turn the Moving Object Detection (MOD) ON/OFF.
- Auto Show Sonar
Allows user to turn the parking sensor system display ON/OFF.
- Front
Allows user to turn the front sensor ON/OFF.
- Rear
Allows user to turn the rear sensor ON/OFF.
- Distance
Allows user to select the sensor range

(Long, Medium or Short).

- Volume
Allows user to select sensor volume (High, Medium or Low).
(See “Moving Object Detection (MOD)” (P.4-23), “Parking sensor system” (P.5-164) and “Rear parking sensor system” (P.5-169).)

Rear Cross Traffic Alert:

Allows user to turn the Rear Cross Traffic Alert system ON/OFF. (See “Rear Cross Traffic Alert (RCTA)” (P.5-62).)

Driver Attention Alert:

Allows the customer to turn the Driver Attention Alert (DAA) on or off. (See “Driver Attention Alert (DAA)” (P.5-143).)

Timer Alert:

Allows user to adjust the Timer Alert or reset.

- Current Time/Set Time
- Reset

Low Temp. Alert:

Allows user to turn the Low Temperature Alert function ON/OFF.

Personal Display

To change the display in the “Personal Display” menu, use the scroll dial ① to select and change a menu item:

- Blank
- Navigation
- Time to Destination
- Fuel Economy
 - Manual Reset1
 - Manual Reset2
 - Auto Refuel
- Trip
 - Manual Reset1
 - Manual Reset2
 - Auto Refuel
- Gear Position
- Average Speed
 - Manual Reset1
 - Manual Reset2
 - Auto Refuel

See “Personal Display (model with full-screen display)” (P.2-22).

Head-Up Display

To change the status or turn on or off any of the systems displayed in the “Head-Up Display” menu, use the scroll dial button ① to select and change a menu item:

- Brightness
- Height
- Rotation
- Displayed information
 - Navigation
 - Driving Assist
 - Traffic Sign
 - Audio
 - TEL/SMS
- Reset Settings

(See “Head-Up Display (HUD)” (P.2-43).)

ECO Mode Setting

This setting allows you to change the ECO mode system settings.

To change the status or turn on or off any of the systems displayed in the “ECO Mode Setting” menu, use the scroll dial ① to select and change a menu item:

- ECO Drive Assist
 - ECO Indicator
 - ECO Drive Report

- View History
 - To reset the View History:
 - 1) Select “View History” using the scroll dial ① and push it.
 - 2) Push the scroll dial ①.
 - 3) Select “Yes” by pushing the scroll dial ①.
- Tire Pres Eco advice
 - Push the scroll dial to turn the “Tire Pres Eco advice” ON/OFF.

TPMS setting

The settings under the “TPMS setting” menu is related to the Tire Pressure Monitoring System (TPMS). (See “Tire Pressure Monitoring System (TPMS)” (P.5-6), “Tire Pressure Monitoring System (TPMS)” (P.6-3), “Tire Pressure Monitoring System (TPMS)” (P.8-25).)

- Tire Pressure Unit

Tire Pressure Unit:

The unit for tire pressure that displays in the multi-information display can be changed to:

- psi
- kPa
- bar
- Kg_f/cm²

Use the scroll dial ① to select and change the unit.

If necessary, refer to the following table to convert between units.

kPa	200	210	220	230	240	250	260	270	280	290	300	310	320	330	340
psi	29	30	32	33	35	36	38	39	41	42	44	45	46	48	49
bar	2.0	2.1	2.2	2.3	2.4	2.5	2.6	2.7	2.8	2.9	3.0	3.1	3.2	3.3	3.4
kgf/cm ²	2.0	2.1	2.2	2.3	2.4	2.5	2.6	2.7	2.8	2.9	3.0	3.1	3.2	3.3	3.4

WAC0569X

Clock

Allows user to adjust the clock settings and time within the multi-information display. The available items vary depending on the vehicle's equipment.

- Clock Mode
- Clock Format
- Daylight Saving Time
- Time Zone
- Set Clock Manually

The clock may also be set in the center (audio) display. For additional information, refer to the separate Smartphone-link Display Audio (SDA) Owner's Manual.

Vehicle Settings

The vehicle settings allows the customer to change settings for the following settings if the vehicle is equipped with them. The displayed menu items vary depending on the vehicle's equipment.

- Electric Tail Gate
- Lighting
- Turn Indicator
- Locking
- Wiper
- Driving Position
- Rear Seat Alert

The vehicle settings can be changed using the

scroll dial  button.

Electric Tail Gate:

This allows the user to turn the Electric Tail Gate ON or OFF.

Lighting:

The “Lighting” menu has the following options:

- Welcome Light
The welcome lighting can be set to be ON or OFF. From the “Lighting” menu, select “Welcome Light”. Use the scroll dial to turn this feature ON or OFF.
- Auto Room Lamp
The interior light timer can be set to be ON or OFF. From the “Lighting” menu, select “Auto Room Lamp”. Use the scroll dial to turn this feature ON or OFF.
- Accent Lighting
The brightness of the Accent Lighting can be adjusted. From the “Lighting” menu, select “Accent Lighting”. Use the scroll dial to select the brightness.

Locking:

There are the following options in the “Locking” menu:

- Ext. Door Switch
When this item is turned on, the request switches on the doors and the liftgate are

activated. From the “Locking” menu, select “Ext. Door Switch”. Use the scroll dial to activate or deactivate this function.

- Selective Unlock
When this item is turned on, and the request switch is pushed, only the corresponding door or the liftgate is unlocked. All the doors can be unlocked if the door handle request switch is pushed again within 2 seconds. When this item is turned to off, all the doors will be unlocked when the door handle request switch is pushed once. From the “Locking” menu, select “Selective Unlock”. Use the scroll dial  to activate or deactivate this function.
- Auto Door Unlock
The “Auto Door Unlock” feature allows the customer to customize the auto door unlock options.
 - Shift to P
 - IGN OFF
 - OFF
- Horn beeps on lock
When the horn beeps on lock is on, the horn will chirp and the hazard indicators will flash when locking the vehicle with the F.A. S.T.-key.
- Auto Door Lock
The “Auto Door Lock” feature allows the customer to customize the auto door unlock

options.

- Vehicle Speed
- Shift out of Park
- OFF

Wiper:

There are the following options in the “Wiper” menu:

- Speed Sensing
The “Speed Sensing Wiper” feature can be activated or deactivated. From the “Wiper” menu, select “Speed Sensing”. Use the scroll dial to turn this feature ON or OFF.
- Rain Sensor
The “Rain Sensor” feature can be activated or deactivated. From the “Wiper” menu, select “Rain Sensor”. Use the scroll dial to turn this feature ON or OFF.
- Reverse Link
The “Reverse Link” wiper feature can be set to be ON or OFF. From the “Wiper” menu, select “Reverse Link”. Use the scroll dial to turn this feature ON or OFF.

Driving Position:

Displays the available driving position options.

- Exit Seat Slide (Driver)
When this item is turned on, this feature will move the driver’s seat backward for an easy exit when the ignition is turned off and

the driver's door is opened. After getting into the vehicle and placing the ignition switch in the ON position, the driver's seat will move to the previous set position. (See "Driver memory settings" (P.3-37).)

Rear Seat Alert:

The "Rear Seat Alert" feature allows user to customize the Rear Seat Alert options. Use the scroll dial to change the mode.

- Horn & Alert
When selected, the alert is displayed and the horn sounds.
- Alert Only
When selected, only the alert is displayed.
- OFF
When selected, no alert or horn will be active.

(See "Rear Seat Alert" (P.2-62).)

Maintenance

The maintenance mode allows you to set alerts for the reminding of maintenance intervals. The displayed menu items vary depending on the vehicle's equipment. To change an item:

Select "Maintenance" using the scroll dial and push it.

- Oil Control System (if so equipped)
- Oil and Filter (if so equipped)
- Tire
- Other

Oil Control System (if so equipped):

The oil control system can be accessed in the Maintenance portion of the multi-information display settings.

10,000 miles (16,000 km) between oil change intervals for the PR25DD engine.

The oil change interval cannot be adjusted manually.

Display when ignition is ON	Display timing	Action Required
Engine Oil Service due in xxx miles	Remaining oil life is less than 940 miles (1,500 km).	Plan to have your vehicle serviced.
Engine Oil Service due	Remaining oil life is 0 miles (0 km).	Have your vehicle serviced within two weeks or less than 500 miles (800 km).

The oil change interval cannot be adjusted manually.

The distance to oil change interval is calculated depending on the driving conditions and set automatically by the oil control system. A reminder will be displayed when approaching the end of the service interval.

When the Factory Reset option is selected in the multi-information display, the oil control system will also be reset to initial value. Please change the engine oil when Factory Reset is selected.

CAUTION

If the oil replacement indicator is displayed, change the engine oil within two weeks or less than 500 miles (800 km).

Operating the vehicle with deteriorated oil can damage the engine.

To reset oil control system:

1. Place the ignition switch in the ON position.
2. Push the ◀ and ▶ buttons on the steering wheel until “Settings” appears in the multi-information display. Use the scroll dial to select “Maintenance”. Then, push the scroll dial.
3. Select the “Oil Control System” and push the scroll dial.
4. Push the scroll dial according to the reset instructions displayed at the bottom of the “Oil Control System” maintenance screen.

Oil and Filter (if so equipped):

This indicator appears when user set distance comes for changing the engine oil and filter. You can set or reset the distance for checking or replacing these items.

Tire:

This indicator appears when the customer set distance comes for replacing tires. You can set or reset the distance for replacing tires.

WARNING

The tire replacement indicator is not a substitute for regular tire checks, including tire pressure checks. See “Replacing tires and wheels” (P.8-30). Many factors including tire inflation, alignment, driving habits and road conditions affect tire wear and when tires should be replaced. Setting the tire replacement indicator for a certain driving distance does not mean your tires will last that long. Use the tire replacement indicator as a guide only and always perform regular tire checks. Failure to perform regular tire checks, including tire pressure checks could result in tire failure. Serious vehicle damage could occur and may lead to a collision, which could result in serious personal injury or death.

Other:

This indicator appears when the customer set distance comes for checking or replacing maintenance items other than the engine oil, oil filter and tires. Other maintenance items can include such things as air filter or tire rotation. You can set or reset the distance for checking or

replacing the items.

Customize Display

The display settings allows you to choose from the various meter selections. The displayed menu items vary depending on the vehicle’s equipment.

The display settings can be changed using the scroll dial.

Main Menu Selection:

Displays available screens that can be shown in the multi-information display.

The available items vary depending on the vehicle’s equipment.

Navigation Settings:

This menu allows user to turn the Navigation Settings ON or OFF.

Cruise Screen:

The ”Cruise Screen” allows you to turn the cruise screen transition on or off.

Welcome Effect:

The “Welcome Effect” displays the available welcome effect settings.

- Animation

Operation Guidance:

The “Operation Guidance” displays the available light and wiper guidance settings.

The available items vary depending on the vehicle’s equipment.

- Lights
- Wiper
- Seat Memory
- Speed Limiter
- Cruise Control

Units/Language

The units that are shown in the multi-information display can be changed:

- Mileage/Fuel
- Tire Pressure
- Temperature
- Language

Use the scroll dial ① to select and change the units of the multi-information display.

Mileage/Fuel:

The unit for the mileage that displays in the multi-information display can be changed.

Use the scroll dial ① to select and change the unit.

Tire Pressure:

The unit for tire pressures that displays in the multi-information display can be changed.

(See “TPMS setting” (P.2-25).)

Temperature:

The temperature that displays in the multi-information display can be changed from:

- °F
- °C

Use the scroll dial ① to toggle choices.

Language:

The language of the multi-information display can be changed.

Use the scroll dial ① to select and change the language of the multi-information display.

Key-Linked Settings

The Key-Linked Settings can be turned ON/OFF using the scroll dial. It will display the key synchronized and in use for this vehicle.

Factory Reset

The settings in the multi-information display can be reset back to the factory default. To reset the multi-information display:

1. Select “Factory Reset” using the scroll dial and push it.

2. Select “YES” and push the scroll dial to return all settings back to default.

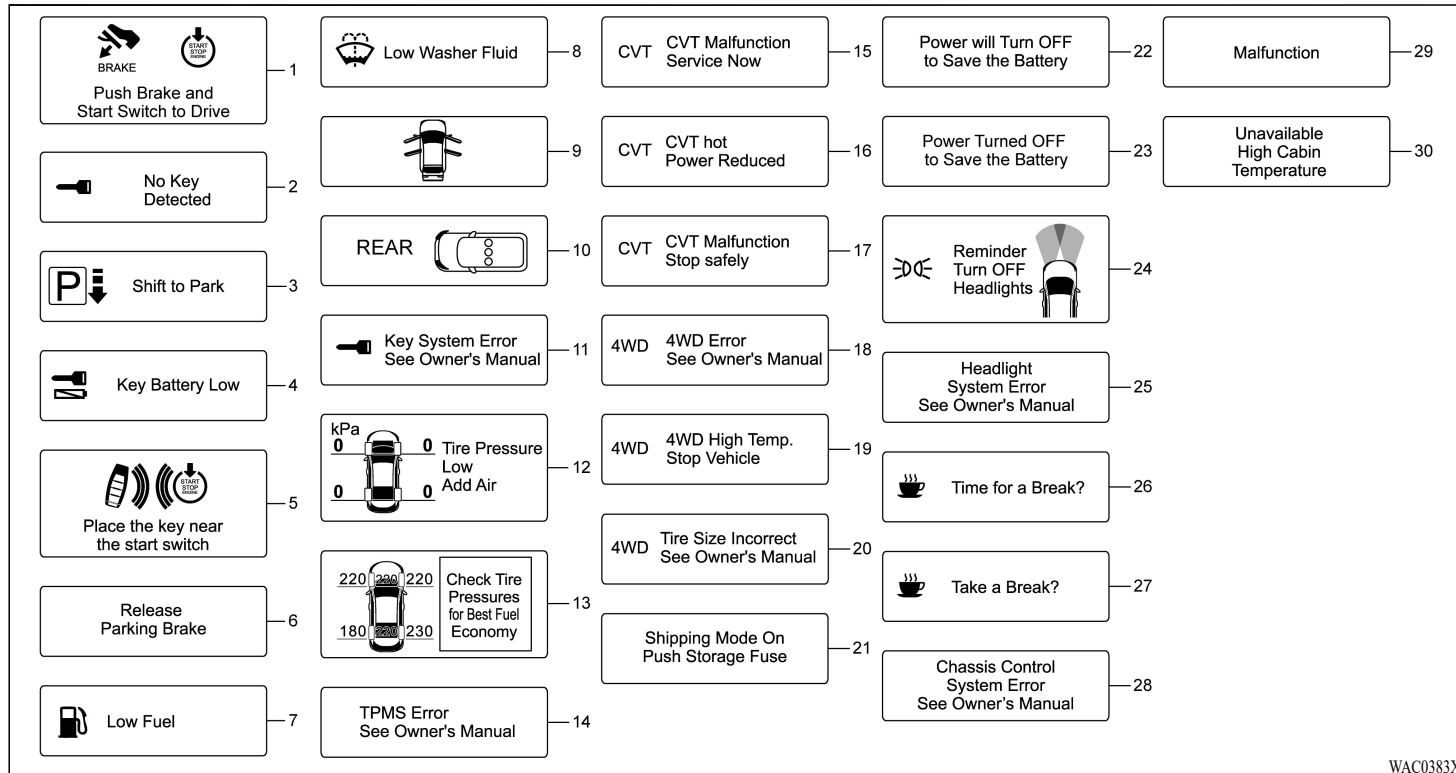

WAC0383X

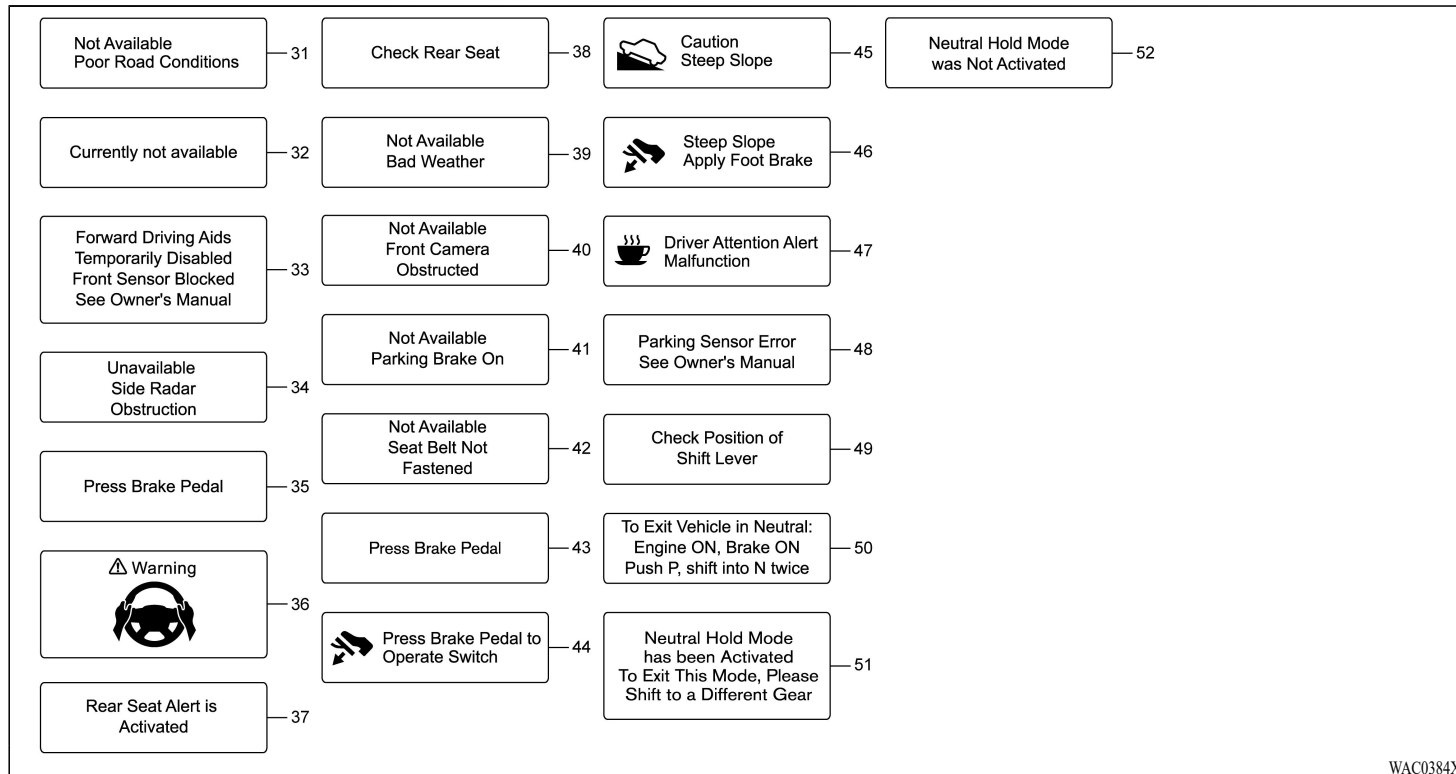

2-32 Instruments and controls

MULTI-INFORMATION DISPLAY WARNINGS AND INDICATORS

NOTE:

The displayed messages are varied depending on the vehicle's specification and equipment.

1. Engine start operation indicator

This indicator appears when the shift lever is in the P (Park) position.

This indicator means that the engine will start by pushing the ignition switch with the brake pedal depressed. You can start the engine directly in any position of the ignition switch.

2. No Key Detected warning

This warning appears when the door is closed with the F.A.S.T.-key left outside the vehicle and the ignition switch in the ON position. Make sure that the F.A.S.T.-key is inside the vehicle.

See "Free-hand Advanced Security Transmitter (F.A.S.T.-key)" (P.3-7) for more details.

3. Shift to Park warning

This warning appears when the door is opened while the shift lever is in positions other than the P (Park) position.

If this warning appears, push the park button to shift to the P (Park) position or place the ignition switch in the ON position.

An inside warning chime will also sound. (See "Free-hand Advanced Security Transmitter (F.A.S.T.-key)" (P.3-7).)

4. Key Battery Low warning

This warning appears when the F.A.S.T.-key battery is running out of power.

If this indicator appears, replace the battery with a new one. See "F.A.S.T.-key battery replacement" (P.8-20).

5. Place the key near the start switch indicator

This indicator appears when the F.A.S.T.-key battery is running out of power and when the F.A.S.T.-key and vehicle are not communicating normally.

If this indicator appears, touch the ignition switch with the F.A.S.T.-key while depressing the brake pedal. (See "F.A.S.T.-key battery discharge" (P.5-15).)

6. Release Parking Brake warning

This warning appears when the vehicle speed is above 2 MPH (4 km/h) and the parking brake is applied. Stop the vehicle and release the parking brake.

7. Low Fuel warning

This warning appears when the fuel level in the fuel tank is getting low. Refuel as soon as it is convenient, preferably before the fuel gauge reaches 0 (Empty). There will be a small reserve of fuel in the tank when the fuel gauge reaches 0 (Empty).

8. Low Washer Fluid warning

This warning appears when the window washer fluid is at a low level. Add window washer fluid as necessary. For additional information, refer to "Window washer fluid" (P.8-10).

9. Door/liftgate open warning

This warning appears if any of the doors and/or the liftgate are open or not closed securely. The vehicle icon indicates which door or the liftgate is open on the display.

10. Rear seat belt warning

This rear seat belt warning appears after the ignition switch is placed in the ON position. If any of the rear passenger's seat belts is not fastened, the seat icon illuminates in red to show which seat belt is not fastened. The seat icon illuminates in red until the corresponding rear passenger's seat belt is fastened. The warning will automatically turn off after approximately 35 seconds. When a rear passenger unfastens the seatbelt while vehicle is stopped, the seat icon illuminates in red. When the vehicle speed exceeds 10 MPH (15 km/h) and if a rear passenger unfastens the seatbelt while driving, a buzzer will sound and the seat icon illuminates in red. The seat icon illuminates in red until the corresponding rear passenger's seat belt is fastened. The warning will automatically turn off after approximately 35 seconds. For precautions on seat belt usage, see "Seat belts" (P.1-16).

11. Key System Error: See Owner's Manual warning

This warning appears if there is a malfunction in the F.A.S.T.-key.

If this warning appears while the engine is stopped, the engine cannot be started. If this warning appears while the engine is running, the vehicle can be driven. However, it is

recommended that you visit an authorized Mitsubishi Motors dealer for repair as soon as possible.

12. Tire Pressure Low — Add Air warning

This warning appears when the low tire pressure warning light in the meter illuminates and low tire pressure is detected. The warning appears each time the ignition switch is placed in the ON position as long as the low tire pressure warning light remains illuminated. If this warning appears, stop the vehicle and adjust the pressure to the recommended COLD tire pressure shown on the Tire and Loading Information placard. (See "Low tire pressure warning light" (P.2-17) and "Tire Pressure Monitoring System (TPMS)" (P.5-6).)

13. Check Tire Pressures for Best Fuel Economy indicator

When this message appears, the tire pressure relatively low or high and not in the range for the best fuel economy. Check the tire pressure and adjust to the designated cold tire pressure. (See "Tire and loading information placard" (P.10-12).)

14. TPMS Error: See Owner's Manual warning

When this warning appears, the system may not be able to detect or signal low tire pressure as intended. TPMS malfunctions may occur for a variety of reasons, including the installation of replacement or alternate tires or wheels on the vehicle that prevent the TPMS from functioning properly.

(See "Tire Pressure Monitoring System (TPMS)" (P.5-6).)

15. CVT Malfunction Service Now warning

This warning illuminates when there is a problem with the CVT system. If this warning comes on, have the system checked. It is recommended that you visit an authorized Mitsubishi Motors dealer for this service.

16. CVT hot Power Reduced warning

This transmission has a high fluid temperature protection mode. If the fluid temperature becomes too high (for example, climbing steep grades in high temperatures with heavy loads, such as when towing a trailer), engine power and, under some conditions, vehicle speed will be decreased automatically to reduce the chance of transmission damage. Vehicle speed can be

controlled with the accelerator pedal, but the engine and vehicle speed may be reduced.

17. CVT Malfunction: Stop safely warning

This warning appears when there is a malfunction with the CVT system. If the warning appears, pull off the road in a safe area and stop the engine immediately. It is recommended that you call an authorized Mitsubishi Motors dealer.

18. 4WD Error: See Owner's Manual warning

This warning appears when the All-Wheel Control (AWC) system is not functioning properly while the engine is running. Reduce vehicle speed and have the system checked. It is recommended that you visit an authorized Mitsubishi Motors dealer for this service. See "S-AWC (Super-All Wheel Control)" (P.5-153).

19. 4WD High Temp. Stop Vehicle warning

This warning appears when the oil temperature of the powertrain parts will increase due to the difference in rotation between the front and rear wheels is large (wheel slip), such as when driving the vehicle on rough roads, through sand or mud, or freeing a stuck vehicle. If this

warning is displayed, stop the vehicle with the engine idling, as soon as it is safe to do so. In these cases, the AWC changes to FWD to protect the powertrain parts. Then if the warning turns off, you can continue AWC driving. See "S-AWC (Super-All Wheel Control)" (P.5-153).

20. Tire Size Incorrect: See Owner's Manual warning

This warning may appear if there is a large difference between the diameters of front and rear wheels and tires. Pull off the road in a safe area, with the engine idling. Check that all the tire sizes, brand, construction and tread pattern are the same, that the tire pressure is correct and that the tires are not excessively worn. If you have any problems, please change tires or adjust the correct tire pressure. Do not select the GRAVEL, SNOW or MUD (AWC model) mode with drive mode selector and do not drive fast. See "Drive Mode Selector" (P.5-28) and "S-AWC (Super-All Wheel Control)" (P.5-153).

21. Shipping Mode On Push Storage Fuse warning

This warning may appear if the extended storage fuse switch is not pushed in (switched on). When this warning appears, push in (switch on) the extended storage fuse switch to turn off the warning. For more information, see "Ex-

tended storage fuse switch" (P.8-19).

22. Power will Turn OFF to Save the Battery warning

This warning appears after the ignition switch is in the ON position for a certain period of time.

23. Power Turned OFF to Save the Battery warning

This warning appears after the ignition switch is automatically turned OFF to save the battery.

24. Reminder: Turn OFF Headlights warning

This warning appears when the driver side door is opened with the headlight switch is left ON and the ignition switch is placed in the OFF or LOCK position. Place the headlight switch in OFF or AUTO (if so equipped) position. For additional information, see "Headlight and turn signal switch" (P.2-53).

25. Headlight System Error: See Owner's Manual warning

This warning appears if the LED headlights are malfunctioning. Have the system checked. It is recommended that you visit an authorized Mitsubishi Motors dealer for this service.

26. Time for a Break? indicator

This indicator appears when the set “Time for a Break?” indicator activates. You can set the time for up to 6 hours.

27. Take a Break? indicator

This indicator appears when the Driver Attention Alert (DAA) system detects driver fatigue or that driver attention is decreasing. (See “Driver Attention Alert (DAA)” (P.5-143).)

28. Chassis Control System Error: See Owner’s Manual warning

This warning appears if the chassis control module detects an error in the chassis control system. Have the system checked. It is recommended that you visit an authorized Mitsubishi Motors dealer for this service. (See “Chassis control” (P.5-160).)

29. Malfunction warning

This warning appears when the following systems malfunction if the vehicle is equipped with them.

- Active Blind Spot Assist (ABSA)
- Rear Cross Traffic Alert (RCTA)
- Traffic Sign Recognition (TSR)
- Forward Collision Mitigation System (FCM)

- Predictive Forward Collision Warning (PFCW)

For more details, see “Active Blind Spot Assist (ABSA)” (P.5-51), “Rear Cross Traffic Alert (RCTA)” (P.5-62), “Traffic Sign Recognition (TSR)” (P.5-30), “Forward Collision Mitigation System (FCM)” (P.5-126) or “Predictive Forward Collision Warning (PFCW)” (P.5-135).

30. Unavailable High Cabin Temperature warning

This warning appears if the interior temperature of the vehicle has reached such a high temperature that the sensor for the Active Blind Spot Assist (ABSA), Lane Departure Warning (LDW) (if so equipped), Lane Departure Prevention (LDP) (if so equipped) or Traffic Sign Recognition (TSR) (if so equipped) system can no longer function reliably. Once the interior temperature has reached normal levels, the warning should disappear.

If the warning continues to display, have the system checked. It is recommended that you visit an authorized Mitsubishi Motors dealer for this service.

For additional information, refer to “Active Blind Spot Assist (ABSA)” (P.5-51), “Lane Departure Warning (LDW)” (P.5-33), “Lane Departure Prevention (LDP)” (P.5-38) or “Traffic Sign Recognition (TSR)” (P.5-30).

31. Not Available: Poor Road Conditions warning

This message appears when Adaptive Cruise Control System (ACC) or Active Blind Spot Assist (ABSA) system becomes unavailable because the road is slippery. For additional information, refer to “Adaptive Cruise Control System (ACC)” (P.5-71), “Adaptive Cruise Control System (ACC) with Stop & Go” (P.5-103) or “Active Blind Spot Assist (ABSA)” (P.5-51).

32. Currently not available warning

This message appears when the Active Blind Spot Assist (ABSA), Lane Departure Prevention (LDP) system or the Adaptive Cruise Control System (ACC) system becomes unavailable because the ASC is turned off. For additional information, refer to “Active Blind Spot Assist (ABSA)” (P.5-51), “Lane Departure Prevention (LDP)” (P.5-38), “Adaptive Cruise Control System (ACC)” (P.5-71) or “Adaptive Cruise Control System (ACC) with Stop & Go” (P.5-103).

33. Forward Driving Aids Temporarily Disabled Front Sensor Blocked See Owner's Manual warning

If the front radar sensor area is covered with dirt or obstructed, making it impossible to detect a vehicle ahead, Forward Collision Mitigation System (FCM), Predictive Forward Collision Warning (PFCW), Adaptive Cruise Control (ACC) or MI-PILOT Assist system is automatically turned off if the vehicle is equipped with them. The warning message will appear in the multi-information display. If the warning message appears, park the vehicle in a safe location and turn the engine off.

Check to see if the front radar sensor area is blocked. If the front radar sensor area is blocked, remove the blocking material. Restart the engine. If the warning message continues to appear, have the Forward Collision Mitigation System (FCM), Predictive Forward Collision Warning (PFCW), Adaptive Cruise Control (ACC) or MI-PILOT Assist system checked. It is recommended that you visit an authorized Mitsubishi Motors dealer for this service.

For more details, see “Forward Collision Mitigation System (FCM)” (P.5-126), “Predictive Forward Collision Warning (PFCW)” (P.5-135), “Adaptive Cruise Control System (ACC)” (P.5-71) or “MI-PILOT Assist” (P.5-90).

34. Unavailable Side Radar Obstruction warning

This warning appears when the Blind Spot Warning (BSW), Active Blind Spot Assist (ABSA) or Rear Cross Traffic Alert (RCTA) system becomes unavailable because a radar blockage is detected. (See “Blind Spot Warning (BSW)” (P.5-43), “Active Blind Spot Assist (ABSA)” (P.5-51) or “Rear Cross Traffic Alert (RCTA)” (P.5-62).)

35. Press Brake Pedal warning

This indicator appears in the following situations:

- The driver tries to release the electric parking brake manually without depressing the brake pedal.
- The vehicle is stopped on a steep hill and there is a possibility of moving backward, even if the electric parking brake is applied.
- This warning appears if the vehicle moves while the Brake Auto Hold is activated.

36. Lane Keep Assist (LKA) alert

This message may appear when the Lane Keep Assist (LKA) system is engaged.

It will be displayed under the following condition:

- When not holding the steering wheel or when there is no steering wheel operation. Hold on the steering wheel immediately. When the steering operation is detected, the warning turns off and the Lane Keep Assist (LKA) function is automatically restored. For additional information, refer to “MI-PILOT Assist” (P.5-90).

37. Rear Seat Alert is Activated

When the system is enabled, this message appears when the Rear Seat Alert system is active and can remind the driver to check the back seat.

- Using the steering switch, a driver can select “Dismiss Message” to clear the display for a period of time. If no selection is made, this message automatically turns off after a period of time.
- Using the steering switch, a driver can select “Disable Alert” to disable the horn alert for the remainder of the current trip.

For additional information, see “Rear Seat Alert” (P.2-62).



WARNING

Selecting “Dismiss Message” during a stop within a trip temporarily dismisses the message for that stop without turning the system off.

Alerts can be provided for other stops during the trip. Selecting “Disable Alert” turns off the Rear Seat Alert system for the remainder of a trip and no audible alert will be provided.

NOTE:

This system is disabled until a driver enables it using the multi-information display. See “Vehicle Settings” (P.2-26).

38. Check Rear Seat

When the system is enabled, this message appears when the vehicle comes to a complete stop, the shift lever is moved from the D (Drive) position to P (Park) position, and the driver exits the vehicle. This message alerts the driver, after a period of time, to check for items in the rear seat after the audible alert has been provided.

NOTE:

This system is disabled until a driver enables it using the multi-information display. For additional information, see “Vehicle Settings” (P.2-26).

39. Not Available Bad Weather

This message may appear when the Lane Keep Assist (LKA) system is engaged.

Under the following conditions, the Lane Keep Assist (LKA) system is automatically canceled:

- When the wiper (HI) operates.
- When lane markers in the traveling lane cannot be correctly detected for a period of time due to such items as a snow rut, reflection of light on a rainy day or several unclear lane markers are present.

If you want to use the Lane Keep Assist (LKA) system again, cancel the MI-PILOT Assist system and set it again when lane markers are clearly visible.

40. Not Available Front Camera Obstructed

This message may appear when the Adaptive Cruise Control System (ACC) system is engaged.

Under the following conditions, the ACC system is automatically canceled:

- The camera area of the windshield is fogged up or covered with dirt, water, drops, ice, snow, etc.
- Strong light, such as sunlight or high beams from oncoming vehicles, enter the front camera

41. Not Available Parking Brake On

This message may appear when the Adaptive Cruise Control System (ACC) system is engaged.

Under the following condition, the ACC system is automatically canceled:

- The electric parking brake is applied.

The above system cannot be used when the electric parking brake is activated.

42. Not Available Seat Belt Not Fastened

This message may appear when the Adaptive Cruise Control System (ACC) system is engaged.

Under the following condition, the ACC system is automatically canceled:

- When the driver’s seat belt is not fastened.

The ACC system cannot be used when the driver’s seat belt is not fastened.

43. Press Brake Pedal

This message may appear when the Adaptive Cruise Control System (ACC) system is engaged.

It will be displayed under the following condition:

- While the vehicle is stopped by the ACC , the driver's door is opened but the electric parking brake was not activated.

Step on the brake immediately.

44. Press Brake Pedal to Operate Switch warning

This warning appears if the Brake Auto Hold switch is pushed without depressing the brake pedal while the Brake Auto Hold function is activated. Depress the brake pedal and push the switch to deactivate the Brake Auto Hold function. For more details, see "Brake Auto Hold" (P.5-25).

45. Caution Steep Slope indicator

This indicator appears when the Brake Auto Hold function is activated while the vehicle is on a steep hill.

46. Steep Slope Apply Foot Brake warning

This warning appears before the electric parking brake is applied and the brake force of the Brake Auto Hold function is released when the vehicle is on a steep hill, to prevent the vehicle rolls out.

47. Driver Attention Alert Malfunction warning

This warning appears when the Driver Attention Alert (DAA) system malfunctions. For more details, see "Driver Attention Alert (DAA)" (P.5-143).

48. Parking Sensor Error: See Owner's Manual warning

This warning illuminates when there is a malfunction with the parking sensor system. For additional information, refer to "Parking sensor system" (P.5-164).

49. Check Position of Shift Lever

This warning appears if the system cannot detect the shift position. Make sure the vehicle is placed in a position properly. Have the system checked. It is recommended you contact an authorized Mitsubishi Motors dealer for this service.

50. Neutral hold mode guidance indicator

This indicator appears when the power switch is placed in the "OFF" position while the shift lever is in the "N" (Neutral) position (Neutral hold mode is available). (See "Neutral hold mode function" (P.5-20).)

51. Neutral hold mode activated indicator

This indicator appears when the Neutral hold mode is activated. To exit the Neutral hold mode, place the vehicle in other than "N" (Neutral) position. (See "Neutral hold mode function" (P.5-20).)

52. Neutral hold mode was not activated indicator

This indicator appears when the Neutral hold mode is unavailable. To activate the Neutral hold mode, wait for a while without shifting and then perform the operations again. (See "Neutral hold mode function" (P.5-20).)

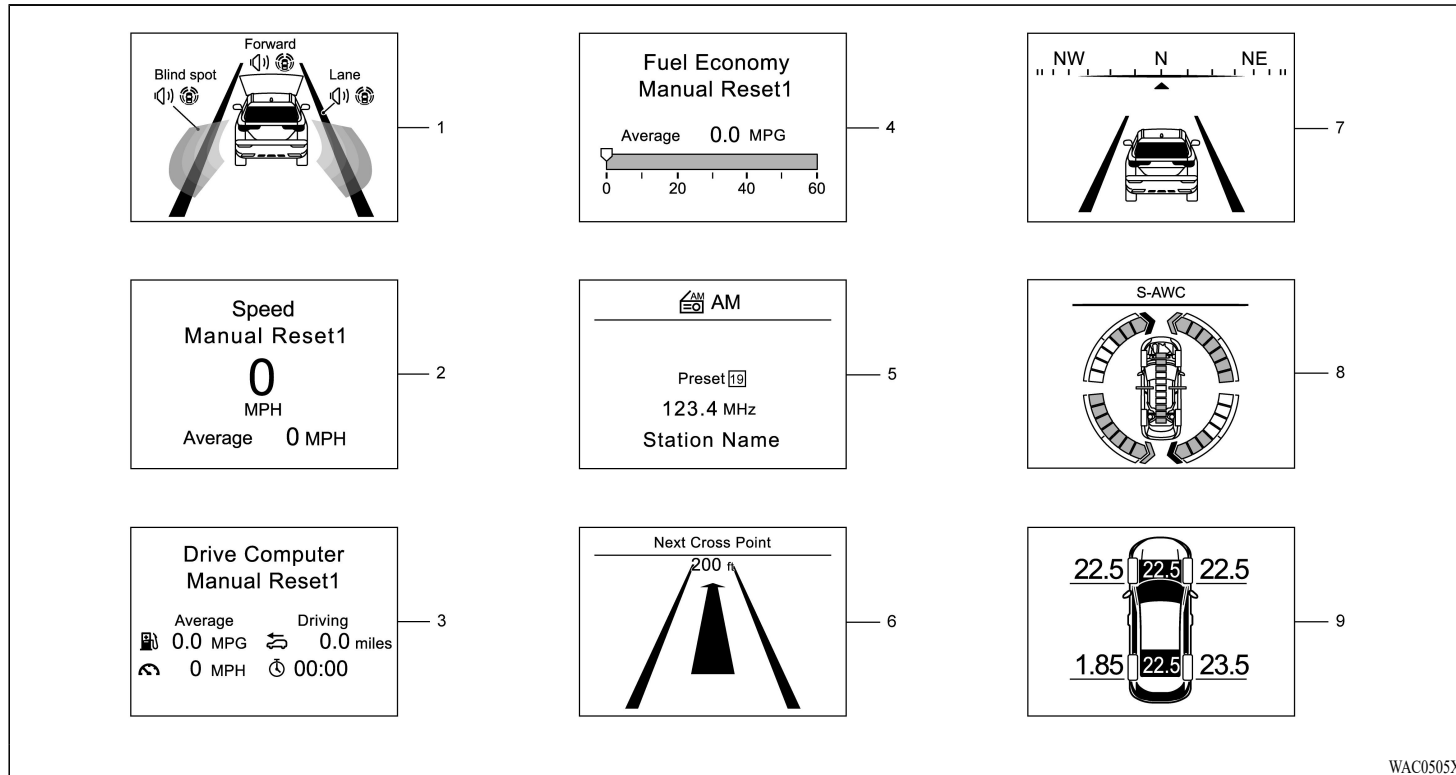

2-40 Instruments and controls

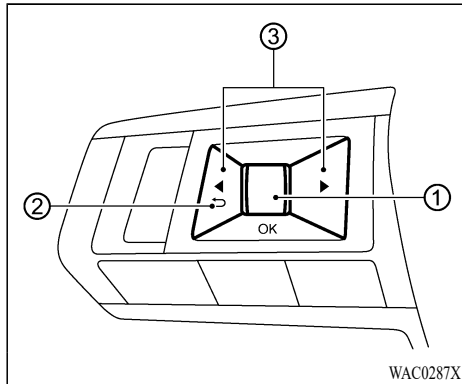

Condition:

[Edit: 2021/ 2/ 10 Model: DG-D]



TRIP COMPUTER

Switches for the trip computer are located on the left side of the steering wheel.

- ① Scroll dial button - navigate through the items and change or select an item in multi-information display
- ②  - go back to the previous menu
- ③  - change from one display screen to the next (i.e. Home, Fuel economy, S-AWC)

1. Driver assistance

The driver assistance mode shows the operating condition for the following systems if the vehicle is equipped with them.

- Lane Departure Warning (LDW)
- Lane Departure Prevention (LDP)
- Blind Spot Warning (BSW)
- Active Blind Spot Assist (ABSA)
- Forward Collision Mitigation System (FCM)
- Predictive Forward Collision Warning (PFCW)

For more details, see “Lane Departure Warning (LDW)” (P.5-33), “Lane Departure Prevention (LDP)” (P.5-38), “Blind Spot Warning (BSW)” (P.5-43), “Active Blind Spot Assist (ABSA)” (P.5-51), “Forward Collision Mitigation System (FCM)” (P.5-126) and “Predictive Forward Collision Warning (PFCW)” (P.5-135).

2. Speed and Average speed (model with type 1 display)

The Speed and Average speed mode shows the current vehicle speed and the average vehicle speed since the last reset. The Speed and Average speed mode have three modes of operation. You can push the scroll dial to switch between Manual reset1, Manual reset2 or Auto Refuel.

Manual reset1 can be reset only manually by using the scroll dial.

Manual reset2 will be reset manually by using the scroll dial, or automatically reset each time the ignition is placed in the OFF position.

Auto Refuel will be reset automatically each time when refueling.

3. Drive Computer

Average fuel consumption:

The average fuel consumption shows the average fuel consumption since the last reset.

Average speed:

The average speed shows the average vehicle speed since the last reset.

Trip odometer:

The trip odometer shows the total distance the vehicle has been driven since the last reset.

Elapsed time:

The elapsed time shows the time since the last reset.

The Drive Computer mode have three modes of operation. You can push the scroll dial to switch between Manual reset1, Manual reset2 or Auto Refuel.

Manual reset1 can be reset only manually by using the scroll dial.

Manual reset2 will be reset manually by using the scroll dial, or automatically reset each time the ignition is placed in the OFF position.

Auto Refuel will be reset automatically each time when refueling.

4. Fuel economy display

Current fuel consumption:

The Fuel economy display mode shows the current fuel consumption.

Average fuel consumption:

The Fuel economy display mode shows the average fuel consumption since the last reset.

The Fuel economy display mode have three modes of operation. You can push the scroll dial to switch between Manual reset1, Manual reset2 or Auto Refuel.

Manual reset1 can be reset only manually by using the scroll dial.

Manual reset2 will be reset manually by using the scroll dial, or automatically reset each time the ignition is placed in the OFF position.

Auto Refuel will be reset automatically each time when refueling.

5. Audio

The audio mode shows the status of audio information.

6. Navigation (if so equipped)

When the route guidance is set in the navigation system, this item shows the navigation route information.

7. Compass (if so equipped)

This display indicates the heading direction of the vehicle.

8. S-AWC operation display (if so equipped)

When the S-AWC operation display is selected, you can view the amount of the yaw moment control and the strength of the traction control between front and rear wheels.

9. Tire Pressures

The tire pressure mode shows the pressure of all four tires while the vehicle is driven.

With the "Tire Pres ECO advice" function ON, when the tire pressure is getting low, "Check Tire Pressures for Best Fuel Economy" appears. (See "TPMS setting" (P.2-25).)

When the Tire Pressure Low - Add Air /Tire Pressure Low - Check Cold Tire warning appears, the display can be switched to the tire

pressure mode by pushing the scroll dial ① to reveal additional details on the displayed warning.

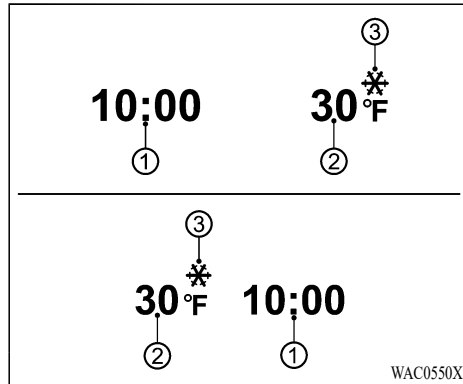

CLOCK AND OUTSIDE AIR TEMPERATURE

The clock ① and outside air temperature ② are displayed on the upper side of the multi-information display.

Clock

For clock adjustment, see “Clock” (P.2-26) or the separate Smartphone-link Display Audio (SDA) Owner’s Manual (if so equipped).

Outside air temperature (°F or °C)

The outside air temperature is displayed in °F or °C in the range of -40 to 140°F (-40 to 60°C).

The outside air temperature mode includes a low temperature warning feature. If the outside air temperature is below 37°F (3°C), the warning ③ is displayed (if so equipped).

The outside temperature sensor is located in front of the radiator. The sensor may be affected by road or engine heat, wind directions and other driving conditions. The display may differ from the actual outside temperature or the temperature displayed on various signs or billboards.

HEAD-UP DISPLAY (HUD) (if so equipped)

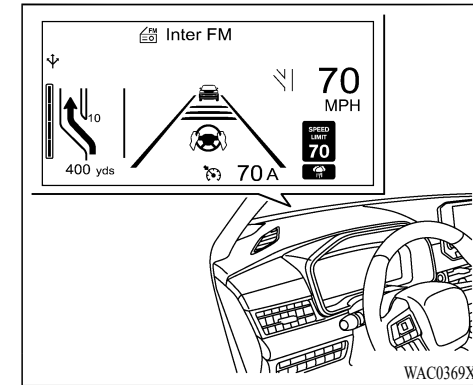

Example

WARNING

- Failure to properly adjust the brightness and position of the displayed image may interfere with the driver’s ability to see through the windshield, which could cause an accident leading to severe injury or death.
- Do not use the Head-Up Display (HUD) for extended periods of time as that can cause you to not see other vehicles, pedestrians or objects, which could cause an accident leading to severe injury or death.

- Do not place any type of liquid on or spray water or spill beverages in the HUD Opening or near.

If the switches, wires, or electrical components become wet, they could malfunction or cause a vehicle fire.

If you accidentally spill a beverage, wipe up as much liquid as possible and immediately consult an authorized Mitsubishi Motors dealer or a repair facility of your choice.

The Head-Up Display (HUD) is displayed on the windshield in front of the driver.

The HUD can display one or more of the following features:

- Vehicle speed
- Navigation (if so equipped)
- Driving Assist
- Traffic Sign (if so equipped)
- Audio
- TEL/SMS

NOTE:

- Do not touch any internal parts of the projector. Doing so may cause malfunction of the equipment.
- To prevent scratches to the projector glass, do not place any sharp objects on or near the projector opening.

- Do not place any objects on the instrument panel which may obstruct the display of the HUD.
- If you wear polarized sunglasses, the display may be difficult to see.
- Depending on weather conditions (rain, snow, sunlight, etc.), the display may be difficult to see.

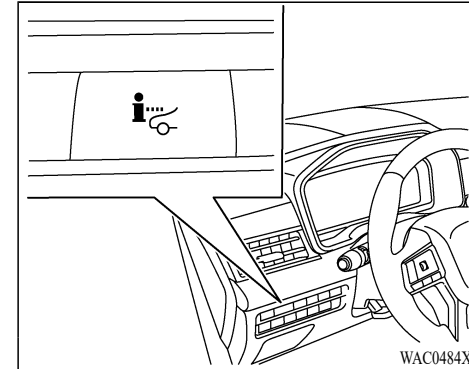

HOW TO USE THE HUD

To turn the HUD system on, push the HUD switch located on the driver's left side instrument panel. To turn the HUD off, push the switch again.

If the HUD system is turned off, it will remain off even if the vehicle is restarted.

The following settings can be changed in the multi-information display:

- Brightness
- Height
- Rotation
- Displayed information

- Reset Settings

NOTE:

Emergency information may display even if the HUD system is turned off.

For more details, refer to the separate Smartphone-link Display Audio (SDA) Owner's Manual.

This product includes the following software.

- (1) Panasonic Corporation or software developed for Panasonic Corporation
- (2) Third-party software licensed to Panasonic Corporation
- (3) Open source software

Regarding (3) Open source software, it includes open source software (OSS), including various software to which license information applies.

Refer to the license web site at: <http://car.panasonic.jp/oss/i021ln39>

Display brightness

The brightness of the display may be controlled in the multi-information display. The brightness will also be adjusted automatically according to the exterior ambient lighting brightness.

For more details, refer to the separate Smartphone-link Display Audio (SDA) Owner's Manual.

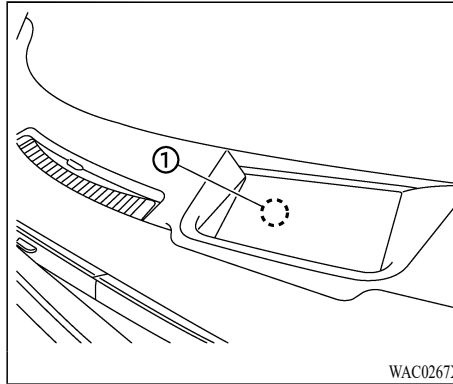

NOTE:

- **The HUD has a built-in sensor ① that controls the brightness of the displayed image. If you block the sensor with an object, the display will darken, making it difficult to see.**
- **Do not expose the HUD sensor to excessive light. This could cause failure or malfunction.**

DRIVER ASSISTANCE/NAVIGATION/TRAFFIC SIGN/AUDIO/TEL/SMS LINKING

The HUD will display driver assistance and navigation information (if so equipped).

The driver assistance display will display warning situations for the following systems if the vehicle is equipped with them:

- Forward Collision Mitigation System (FCM)
- Predictive Forward Collision Warning system
- Cruise control
- Adaptive Cruise Control System (ACC)
- MI-PILOT Assist
- Lane Departure Warning (LDW) system
- Lane Departure Prevention

The Navigation System linking display will display the following items (if so equipped):

- Intersection names
- Arrows indicating turning direction
- Distance to the next intersection
- Recommended lane indicator

For the navigation system, refer to the separate Smartphone-link Display Audio (SDA) Owner's Manual.

The Traffic Signs Recognition System linking

SECURITY SYSTEMS

display will display the following items (if so equipped):

- Speed limit sign

The Audio System linking display will display the following items (if so equipped):

- Songs
- Radio stations
- Television stations

The TEL/SMS linking display will display the following items (if so equipped):

- Caller's name or phone number

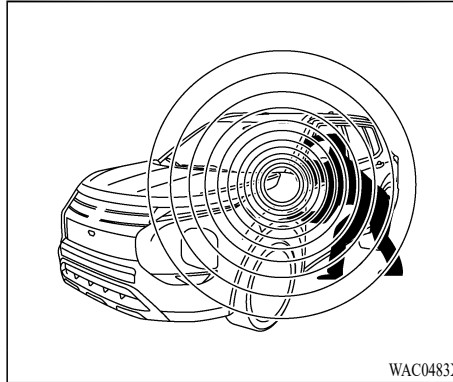

Your vehicle has two types of security systems, as follows:

- Anti-theft alarm system
- Anti-theft engine immobilizer

ANTI-THEFT ALARM SYSTEM

The anti-theft alarm system provides visual and audio alarm signals if someone opens the doors, hood and liftgate when the system is armed. It is not, however, a motion detection type system that activates when a vehicle is moved or when a vibration occurs.

The system helps deter vehicle theft but cannot prevent it, nor can it prevent the theft of interior

or exterior vehicle components in all situations. Always secure your vehicle even if parking for a brief period. Never leave your keys in the vehicle, and always lock it when unattended. Be aware of your surroundings, and park in secure, well-lit areas whenever possible.

How to arm the anti-theft alarm system

1. Close all windows. **The system can be armed even if the windows are open.**
2. Remove the keys from the vehicle.
3. Close all doors, hood and liftgate. Lock all doors. The doors can be locked with F.A.S. T.-key, door handle request switch (if so equipped) or liftgate request switch (if so equipped).

Even when the driver and/or passengers are in the vehicle, the system will activate with all the doors, hood and liftgate locked with the ignition switch placed in the LOCK position. When placing the ignition switch in the ON position, the system will be released.

Anti-theft alarm system activation

The anti-theft alarm system will give the following alarm:

- The headlights blink and the horn sounds intermittently.
- The alarm automatically turns off after approximately 30 seconds. However, the alarm reactivates if the vehicle is tampered with again.

The alarm is activated by:

- opening any doors, the hood or liftgate without using the F.A.S.T.-key (even if the door is unlocked by releasing the door inside lock knob).

How to stop an activated alarm

The alarm stops only by unlocking a door or the liftgate with pressing the UNLOCK  button on the F.A.S.T.-key, or pushing the request switch (if so equipped) on the driver's or passenger's door in range of the door handle.

The alarm also stops when the ignition switch is placed in the ON position.

ANTI-THEFT ENGINE IMMOBILIZER

CAUTION

- Do not make any alterations or additions to the immobilizer system. Alterations or additions could cause failure of the immobilizer.

The anti-theft engine immobilizer will not allow the engine to start without the use of the registered key.

If the engine does not start using the registered F.A.S.T.-key, it may be due to interference caused by:

- Another F.A.S.T.-key.
- Automated toll road device.
- Automated payment device.
- Other devices that transmit similar signals.

Start the engine using the following procedure:

1. Remove any items that may be causing the interference away from the F.A.S.T.-key.
2. Start the engine again.

If this procedure allows the engine to start, Mitsubishi Motors recommends placing the registered F.A.S.T.-key separate from other devices to avoid interference.

NOTE:

- The key may not operate properly when it is near an object or facility that emits strong electromagnetic waves.
- Anti-theft engine immobilizer is not compatible with commercially available remote starting systems. Use of commercially available remote starting systems may result in vehicle starting problems and a loss of security protection.

Statement related to section 15 of FCC rules for Anti-theft engine immobilizer (CONTROL UNIT, KOS)

FCC Notice:

For USA:

FCC ID : KR5MTXN1

FCC ID : KR5HFM401

This device complies with Part 15 of the FCC Rules. Operation is subject to the following two conditions: (1) this device may not cause harmful interference, and (2) this device must accept any interference received, including interference that may cause undesired operation. Changes or modifications not expressly approved by the party responsible for compliance could void the user's authority to operate the equipment.

WIPER AND WASHER SWITCH

For Canada:

IC ID : 7812D-MTXN1

IC ID : 7812D-HFM401

This device complies with Industry Canada licence-exempt RSS standard(s). Operation is subject to the following two conditions: (1) this device may not cause interference, and (2) this device must accept any interference, including interference that may cause undesired operation of the device.

Le présent appareil est conforme aux CNR d'Industrie Canada applicables aux appareils radio exempts de licence. L'exploitation est autorisée aux deux conditions suivantes : (1) l'appareil ne doit pas produire de brouillage, et (2) l'utilisateur de l'appareil doit accepter tout brouillage radioélectrique subi, même si le brouillage est susceptible d'en compromettre le fonctionnement.



WARNING

In freezing temperatures the washer solution may freeze on the windshield and obscure your vision which may lead to an accident. Warm windshield with the defroster before you wash the windshield.



CAUTION

- Do not operate the washer continuously for a long period of time or the pump may fail.
- Do not operate the washer if the reservoir tank is empty.
- Do not fill the window washer reservoir tank with washer fluid concentrates at full strength. Some methyl alcohol based washer fluid concentrates may permanently stain the grille if spilled while filling the window washer reservoir tank.
- Pre-mix washer fluid concentrates with water to the manufacturer's recommended levels before pouring the fluid into the window washer reservoir tank. Do not use the window washer reservoir tank to mix the washer fluid concentrate and water.

If the windshield wiper operation is interrupted by snow or ice, the wiper may stop

moving to protect its motor. If this occurs, turn the wiper switch to the OFF position and remove the snow or ice that is on and around the wiper arms. In approximately 1 minute, turn the switch on again to operate the wiper.

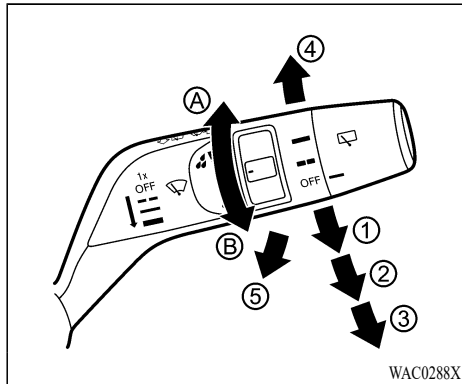

WINDSHIELD WIPER AND WASHER OPERATION

The windshield wiper and washer operates when the ignition switch is in the ON position.

Push the lever down to operate the wiper at the following speed:

- ① Intermittent — intermittent operation can be adjusted by turning the knob toward Ⓐ (Faster) or Ⓑ (Slower). Also, the intermittent operation speed varies in accordance with the vehicle speed. (For example, when the vehicle speed is high, the intermittent operation speed will be faster.)
- ② Low — continuous low speed operation
- ③ High — continuous high speed operation

Push the lever up ④ to have one sweep operation of the wiper.

Pull the lever toward you ⑤ to operate the washer. Then the wiper will also operate several times.

NOTE:

The speed dependent feature may be disabled. For additional information, refer to “Vehicle Settings” (P.2-26).

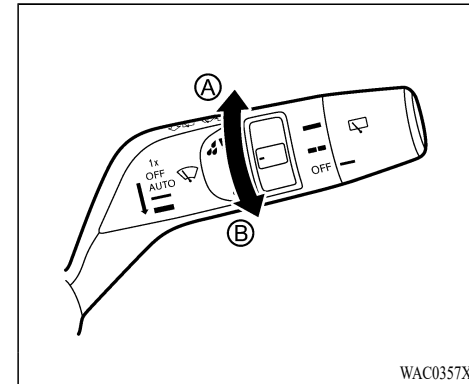

RAIN-SENSING AUTO WIPER SYSTEM (if so equipped)

The rain-sensing auto wiper system can automatically turn on the wipers and adjust the wiper speed depending on the rainfall and the vehicle speed by using the rain sensor located on the upper part of the windshield.

To set the rain-sensing auto wiper system, push the lever down to the AUTO position. The wiper will sweep once while the engine is running.

The rain sensor sensitivity level can be adjusted by turning the knob upwards Ⓐ (High) or downwards Ⓑ (Low).

- High — High sensitive operation
- Low — Low sensitive operation

To turn the rain-sensing auto wiper system off, push up the lever to the OFF position, or pull down the lever to the LO or HI position.

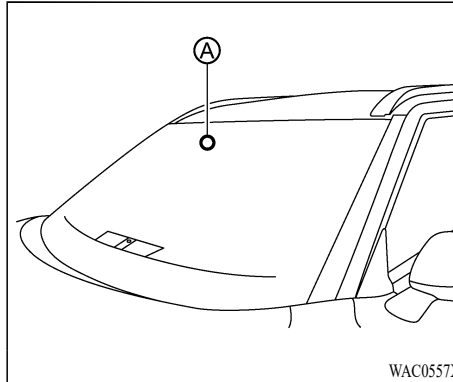

CAUTION

Do not touch the rain sensor **A** and around it when the wiper switch is in the **AUTO** position and the engine is running. The wipers may operate unexpectedly and cause to an injury or may damage a wiper.

- The rain-sensing auto wipers are intended for use during rain. If the switch is left in the **AUTO** position, the wipers may operate unexpectedly when dirt, fingerprints, oil film or insects are stuck on or around the sensor. The wipers may also operate when exhaust gas or moist-

ure affect the rain sensor.

- Do not attach a sticker or label on the windshield. Otherwise the rain sensor may not detect the amount of the water properly and the wiper may not operate automatically.
- If the replacement of the windshield is necessary, it is recommended to contact an authorized Mitsubishi Motors dealer.
- The rain-sensing auto wipers may not operate if rain does not hit the rain sensor even if it is raining.
- When the windshield glass is coated with water repellent, the speed of the rain-sensing auto wipers may be higher even though the amount of the rainfall is small.
- Be sure to turn off the rain-sensing auto wiper system when you use a car wash.
- Using genuine wiper blades is recommended for proper operation of the rain-sensing auto wiper system. (See “Windshield wiper blades” (P.8-15) for wiper blade replacement.)

REAR WINDOW WIPER AND WASHER SWITCH

WARNING

In freezing temperatures the washer solution may freeze on the rear window glass and obscure your vision. Warm the rear window with the defroster before you wash the rear window.

CAUTION

- Do not operate the washer continuously for more than 30 seconds.
- Do not operate the washer if the reservoir tank is empty.
- Do not fill the window washer reservoir tank with washer fluid concentrates at full strength. Some methyl alcohol based washer fluid concentrates may permanently stain the grille if spilled while filling the window washer reservoir tank.
- Pre-mix washer fluid concentrates with water to the manufacturer's recommended levels before pouring the fluid into the window washer reservoir tank. Do not use the window washer reservoir tank to mix the washer fluid concentrate and water.

If the rear window wiper operation is interrupted by snow or ice, the wiper may

stop moving to protect its motor. If this occurs, turn the wiper switch to the OFF position and remove the snow or ice that is on and around the wiper arms. In approximately 1 minute, turn the switch on again to operate the wiper.

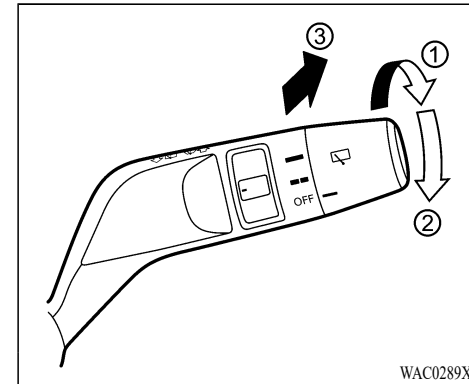

The rear window wiper and washer operate when the ignition switch is in the ON position. Turn the switch clockwise from the OFF position to operate the wiper.

- ① Intermittent (INT) — intermittent operation (not adjustable)
 - ② Low (ON) — continuous low speed operation
- Push the switch forward ③ to operate the washer. Then the wiper will also operate several times.

Reverse Link feature:

When the windshield wiper switch is on, moving the shift lever to the R (Reverse) position will operate the rear window wiper.

ELECTRIC REAR WINDOW AND DOOR MIRROR DEFROSTER SWITCH

NOTE:

The Reverse Link feature may be disabled. For additional information, refer to “Vehicle Settings” (P.2-26).

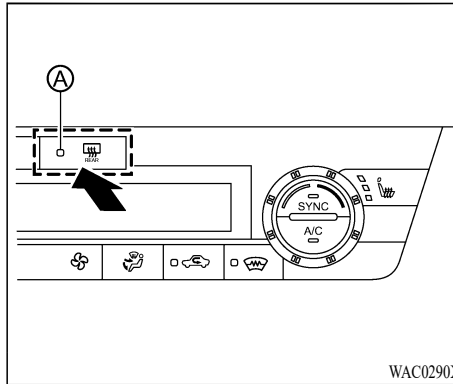

Type A

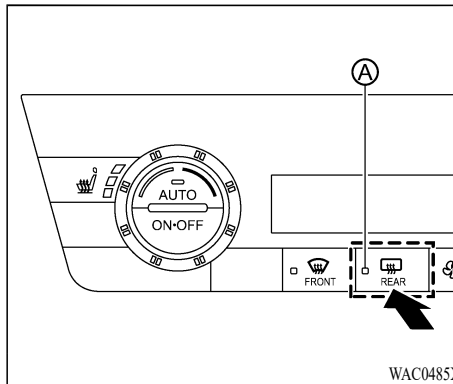

Type B

To defog/defrost the rear window glass and door mirrors (if so equipped), start the engine and push the switch on. The indicator light ① will illuminate. Push the switch again to turn the defroster off.

It will automatically turn off in approximately 20 minutes.

CAUTION

When cleaning the inner side of the rear window, be careful not to scratch or damage the electric rear window defroster.

WIPER DEICER SWITCH (if so equipped)

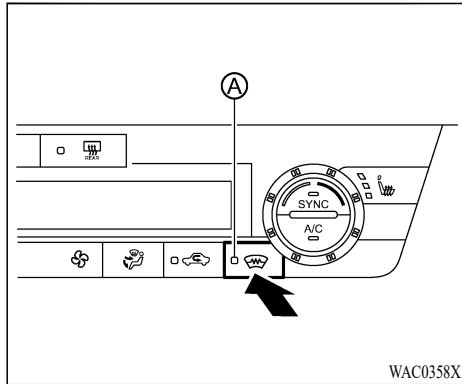

The wiper deicer switch (defroster switch) operates when the engine is running.

The deicer is used to remove ice from the windshield when a wiper is frozen to the windshield.

When the switch is pushed, the indicator light **A** illuminates and the deicer operates for approximately 10 minutes. After the preset time has passed, the deicer will turn off automatically. To turn off the deicer manually, push the deicer switch again, and the indicator light turns off.

CAUTION

- When cleaning the inner side of the window, be careful not to scratch or damage the electrical conductors on the surface of the window.

HEADLIGHT AND TURN SIGNAL SWITCH

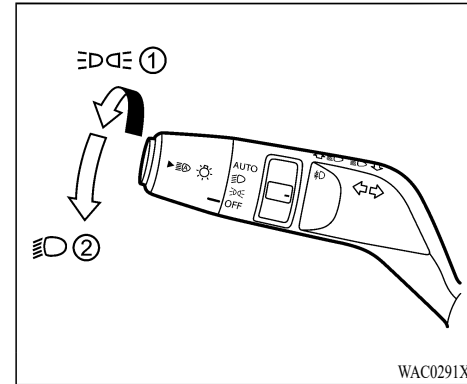

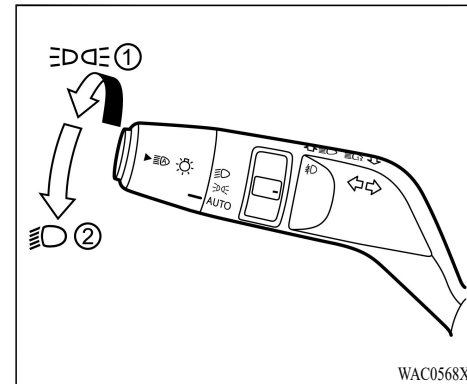

Type A



Type B

HEADLIGHT SWITCH

Lighting

- ① Rotate the switch to the  position, and the front parking, tail, license plate, and instrument panel lights will come on.
- ② Rotate the switch to the  position, and the headlights will come on and all the other lights remain on.

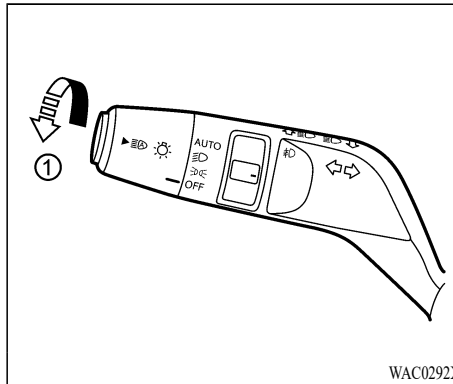

Type A

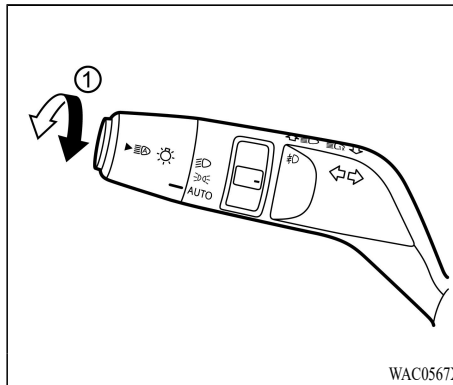



Type B

Auto Headlight system

The Auto Headlight system allows the headlights to be set so they turn on and off automatically.

To set the Auto Headlight system:

1. Make sure the headlight switch is in the AUTO position ①.
2. Start the engine.
3. The Auto Headlight system automatically turns the headlights on and off.

To turn the Auto Headlight system off, turn the switch to the OFF (if so equipped),  or  position.

The Auto Headlight system can turn on the headlights automatically when it is dark and turn off the headlights when it is light.

If the ignition switch is placed in the OFF position and one of the doors is opened and this condition is continued, the headlights remain on for 5 minutes.

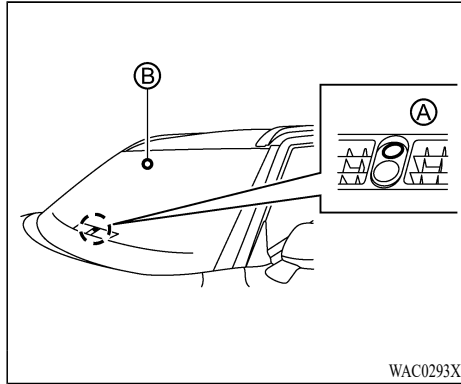

Be sure not to put anything on top of the light sensor ① (if so equipped) located on the top of the instrument panel or rain/light sensor ② (if so equipped) located above the inside mirror. The sensor controls the Auto Headlight; if it is covered, the sensor reacts as if it is dark and the headlights will illuminate.

Models not equipped with rain-sensing auto wiper system:

Do not put anything on or spray glass cleaner on top of the photo sensor, located on the top of the instrument panel. Otherwise the photo sensor may not detect the ambient light and the headlights may not operate automatically.

Models equipped with rain-sensing auto wiper system:

If the replacement of the windshield or the repair on the windshield near the rain sensor is necessary, it is recommended to contact an authorized Mitsubishi Motors dealer.

Headlights off delay:

When the lever is pulled towards the rearmost position after the ignition is switched off, the headlights will turn on and stay on for 30 seconds. The lever can be pulled 4 times for up to 2 minutes.

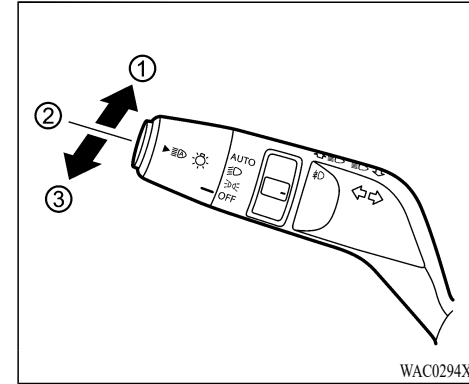

Example

Headlight beam select

- ① To select the high beam function, push the lever forward. The high beam lights come on and the  light illuminates.
- ② Push the lever again to select the low beam.
- ③ Pulling and releasing the lever flashes the headlight high beams on and off.

Automatic High Beam (AHB)

The Automatic High Beam (AHB) system will operate when the vehicle is driven at speeds of approximately 34 MPH (55 km/h) and above. If an oncoming vehicle or leading vehicle appears in front of your vehicle when the headlight high beam is on, the headlight will be switched to the low beam automatically.

Precautions on Automatic High Beam (AHB):

WARNING

- The Automatic High Beam (AHB) system is a convenience but it is not a substitute for safe driving operation. The driver should remain alert at all times, ensure safe driving practices and switch the high beams and low beam manually when necessary.
- The high beam or low beam may not switch automatically under the following conditions. Switch the high beam and low beam manually.
 - During bad weather (rain, fog, snow, wind, etc.).
 - When a light source similar to a headlight or tail light is in the vicinity of the vehicle.

- When the headlights of the oncoming vehicle or the leading vehicle are turned off, when the color of the light is affected due to foreign materials on the lights, or when the light beam is out of position.
- When there is a sudden, continuous change in brightness.
- When driving on a road that passes over rolling hills, or a road that has level differences.
- When driving on a road with many curves.
- When a sign or mirror-like surface is reflecting intense light towards the front of the vehicle.
- When the container, etc. being towed by a leading vehicle is reflecting intense light.
- When a headlight on your vehicle is damaged or dirty.
- When the vehicle is leaning at an angle due to a punctured tire, being towed, etc.
- The timing of switching the low beam and high beam may change under the following situations.

- The brightness of the headlights of the oncoming vehicle or leading vehicle.
- The movement and direction of the oncoming vehicle and the leading vehicle.
- When only one light on the oncoming vehicle or the leading vehicle is illuminated.
- When the oncoming vehicle or the leading vehicle is a two-wheeled vehicle.
- Road conditions (incline, curve, the road surface, etc.).
- The number of passengers and the amount of cargo.

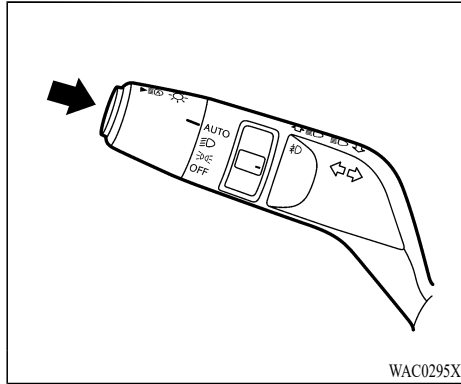

Example

Automatic High Beam (AHB) operations:

To activate the Automatic High Beam (AHB) system, push the switch as illustrated with the AUTO position. The Automatic High Beam (AHB) indicator light in the meter will illuminate while the headlights are turned on.

If the Automatic High Beam (AHB) indicator light does not illuminate in the above condition, it may indicate that the system is not functioning properly. It is recommended you have the system checked by an authorized Mitsubishi Motors dealer.

When the vehicle speed lowers to less than

approximately 28 MPH (45 km/h), the headlight remains the low beam.

To turn off the Automatic High Beam (AHB) system, push the switch again.

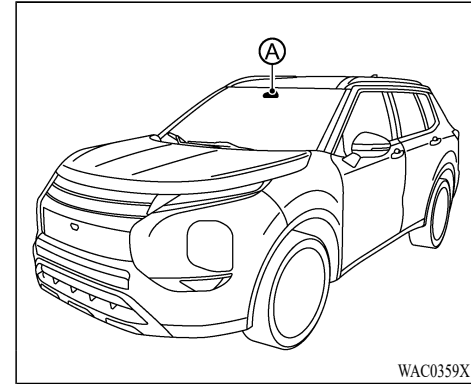





Ambient image sensor maintenance:

The ambient image sensor (A) for the Automatic High Beam (AHB) system is located in front of the inside mirror. To keep the proper operation of the Automatic High Beam (AHB) system and prevent a system malfunction, be sure to observe the following:

- Always keep the windshield clean.
- Do not attach a sticker (including transparent material) or install an accessory near the ambient image sensor.
- Do not strike or damage the areas around the ambient image sensor. Do not touch the sensor lens that is located on the ambient image sensor.

If the ambient image sensor is damaged due to an accident, it is recommended you contact an authorized Mitsubishi Motors dealer.



Battery saver system

- When the headlight switch is in the  or  position while the ignition switch is in the ON position, the lights will automatically turn off within a period of time after the ignition switch has been placed in the OFF position.
- When the headlight switch remains in the  or  position after the lights automatically turn off, the lights will turn on when the ignition switch is placed in the ON position.

CAUTION

- When you turn on the headlight switch again after the lights automatically turn off, the lights will not turn off automatically. Be sure to turn the light switch to the OFF position when you leave the vehicle for extended periods of time, otherwise the battery will be discharged.
- Never leave the light switch on when the engine is not running for extended periods of time even if the headlights turn off automatically.

Daytime running light system

The LED parking lights automatically illuminate at 100% intensity when the engine is started and the parking brake released. The LED daytime running light operate with the headlight switch in the OFF position or in the  position. When you turn the headlight switch to the  position for full illumination, the daytime running light switches to the parking light.

If the parking brake is applied before the engine is started, the daytime running light will not illuminate. The daytime running light illuminate when the parking brake is released. The daytime running light will remain on until the ignition switch is placed in the OFF position.

It is necessary at dusk to turn the headlight switch ON for interior controls and switches to illuminate, as those remain OFF while the switch is in the OFF position.

WARNING

When the daytime running light system is active, tail lights on your vehicle are not on. It is necessary at dusk to turn on your headlights. Failure to do so could cause an accident injuring yourself and others.

HEADLIGHT CLEANER (if so equipped)

The headlight cleaner operates when the headlight is on and the ignition switch is in the ON position.

The headlight cleaner operates when:

- the first windshield washer operation after the ignition switch turns on.
- every tenth windshield washer operation after the ignition switch turns on.
- the windshield washer switch is pulled and hold.

CAUTION

Do not operate the headlight cleaner if the window washer fluid reservoir is empty.

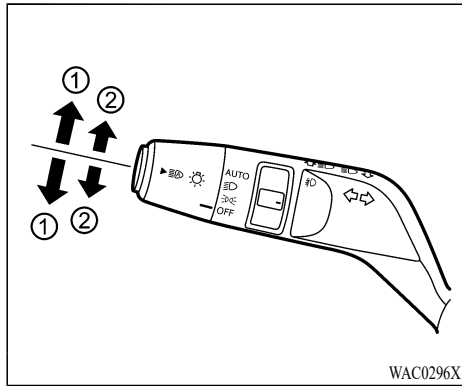

Example

TURN SIGNAL SWITCH

① Turn signal

Move the lever up or down to signal the turning direction. When the turn is completed, the turn signals cancel automatically.

② Lane change signal

When moving the lever to ② slightly to change a lane, the turn signal light and indicator light in the instrument cluster will only flash while the lever is operated.

Also, when you move the lever to ② slightly then release it, the turn signal light and indicator light in the instrument cluster will flash three times.

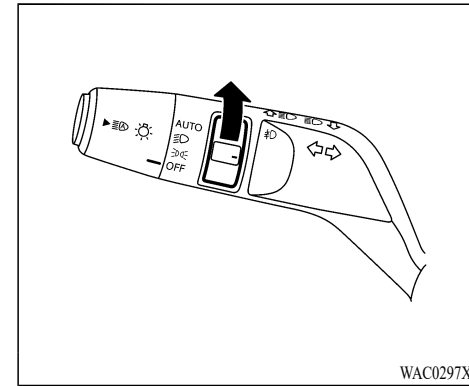

Example

FOG LIGHT SWITCH (if so equipped)

To turn the fog lights on, turn the headlight switch to the ☀ position, then turn the fog light switch to the ☁ position.

To turn the fog lights on with the headlight switch in the AUTO position (if so equipped), the headlights must be on, then turn the fog light switch to the ☁ position.

To turn them off, turn the fog light switch to the OFF position.

The headlights must be on for the fog lights to operate. The fog lights automatically turn off when the high beam headlights are selected.

HORN

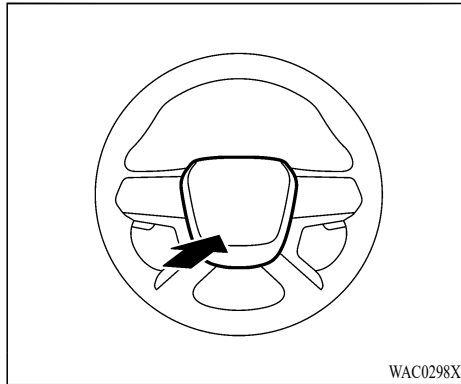

To sound the horn, push the center pad area (🔊) of the steering wheel.

WARNING

Do not disassemble the horn. Doing so could affect proper operation of the supplemental front airbag system. Tampering with the supplemental front airbag system may result in serious personal injury.

HEATED STEERING WHEEL (if so equipped)

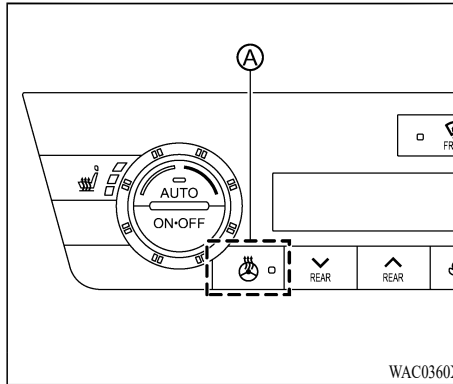

The heated steering wheel system is designed to operate only when the surface temperature of the steering wheel is below 68°F (20°C).

Push the heated steering wheel switch (A) to warm the steering wheel after the engine starts. The indicator light on the switch will illuminate.

If the surface temperature of the steering wheel is below 68°F (20°C), the system will heat the steering wheel and cycle off and on to maintain a temperature above 68°F (20°C). The indicator light will remain on as long as the system is on.

The heated steering wheel system is automatically turned off after 30 minutes.

Push the switch again to turn the heated steering wheel system off manually. The indicator light

will turn off.

NOTE:

If the surface temperature of the steering wheel is above 68°F (20°C) when the switch is turned on, the system will not heat the steering wheel. This is not a malfunction.

HEATED SEATS (if so equipped)

WARNING

Do not use or allow occupants to use the seat heater if you or the occupants cannot monitor elevated seat temperatures or have an inability to feel pain in body parts that contact the seat. Use of the seat heater by such people could result in serious injury.

CAUTION

- Do not use the seat heater for extended periods or when no one is using the seat.
- Do not put anything on the seat which insulates heat, such as a blanket, cushion, seat cover, etc. Otherwise, the seat may become overheated.
- Do not place anything hard or heavy on the seat or pierce it with a pin or similar object. This may result in damage to the heater.
- Any liquid spilled on the heated seat should be removed immediately with a dry cloth.
- When cleaning the seat, never use gasoline, thinner, or any similar materials.
- If any malfunctions are found or the heated seat does not operate, turn the switch off and have the system checked. It

is recommended you visit an authorized Mitsubishi Motors dealer for this service.

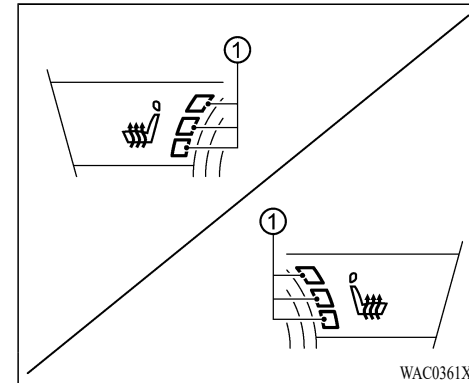

Front

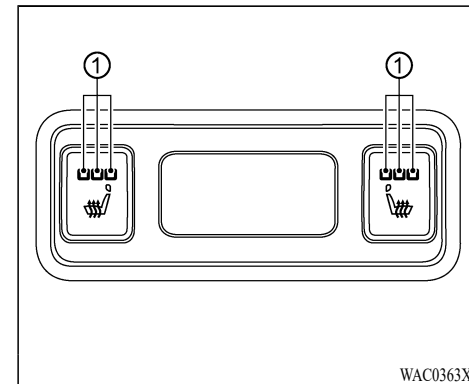

Rear

Instruments and controls 2-61

The front and rear (if so equipped) seats are warmed by built-in heaters. The switches are located on the instrument panel and the back of the center console box and can be operated independently of each other.

OPERATION WITH SWITCH

1. Start the engine.
2. Push the heated seat switch and select the desired heat range.
 - For high heat, push the switch once.
 - For medium heat, push the switch twice.
 - For low heat, push the switch three times.
 - The indicator light ① on the switch will illuminate depending on the heat level when the heater is on.
3. To turn off the heater, push the heated seat switch until the indicator light turns off.

The heater is controlled by a control module, automatically turning the heater on and off.

The indicator light will remain on as long as the switch is on.

When the vehicle's interior is warmed, or before you leave the vehicle, be sure to turn off the seat heater.

REAR SEAT ALERT

The Rear Seat Alert system functions under certain conditions to indicate there may be an object or passenger in the rear seat(s). Check the seat(s) before exiting the vehicle.

The Rear Seat Alert system is initially disabled. The driver can enable the system using the multi-information display. For additional information, see "Vehicle Settings" (P.2-26).

When the system is enabled:

- The system is activated when a rear door is opened and closed within 10 minutes of the vehicle being driven. When the vehicle is started and the system is activated, a visual message appears in the multi-information display. For additional information, see "37. Rear Seat Alert is Activated" (P.2-37).
- If a rear door is opened and closed but the vehicle is not driven within approximately 10 minutes, the system will not be activated. A rear door must be opened and closed and the vehicle is driven within 10 minutes for the system to activate.

When the Rear Seat Alert system is activated and a driver exits the vehicle after arriving at a destination:

- When the driver puts the vehicle in the P (Park) position, a message appears in the multi-information display for the driver to "Dismiss Message" or "Disable Alert" if desired.

- With the system enabled, when the driver exits the vehicle, an audible alert (horn sound) will occur unless a rear door is opened and closed within a short time to deactivate the alert.
- If the doors are locked before the alert is deactivated by opening a rear door, the horn will sound.
- If the system is activated but the liftgate is opened before opening a rear door, the horn will be delayed until after the liftgate is closed.
- If the audible horn alert occurs, a message will also appear in the multi-information display that states, "Check Rear Seat". For additional information, see "38. Check Rear Seat" (P.2-38).



WARNING

- If the driver selects "Disable Alert", no audible alert will be provided regardless of rear door open/close status.
- There may be times when there is an object or passenger in the rear seat(s) but the audible alert does not sound. For example, this may occur if rear seat passengers enter or exit the vehicle during a trip.
- The system does not directly detect objects or passengers in the rear seat(s). Instead, it

POWER OUTLET

can detect when a rear door is opened and closed, indicating that there may be something in the rear seat(s).

NOTE:

There may be times when the horn sounds but there are no objects or passengers in the rear seat(s).

For additional information, see “37. Rear Seat Alert is Activated” (P.2-37).

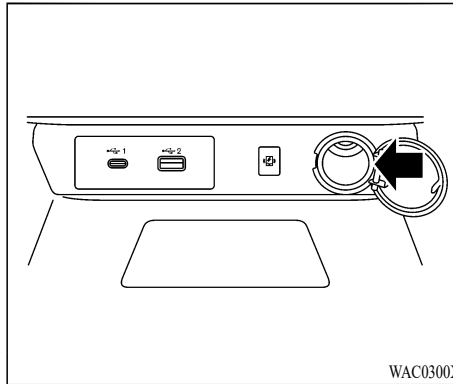

Instrument Panel

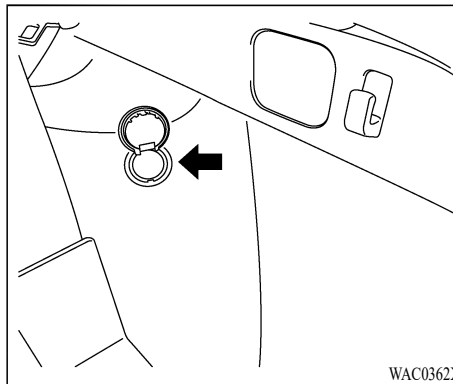

Cargo area

The power outlet is located in the instrument panel and cargo area.

CAUTION

- The outlet and plug may be hot during or immediately after use.
- Do not use with accessories that exceed a 12 volt, 120W (10A) power draw. Do not use double adapters or more than one electrical accessory.
- Use power outlet with the engine running to avoid discharging the vehicle battery.
- Avoid using power outlet when the air conditioner, headlights or electric rear window defroster is on.
- This power outlet is not designed for use with a cigarette lighter unit.
- Push the plug in as far as it will go. If good contact is not made, the plug may overheat or the internal temperature fuse may open.
- Before inserting or disconnecting a plug, be sure the electrical accessory being used is turned OFF.
- When not in use, be sure to close the cap. Do not allow water or any liquid to contact the outlet.

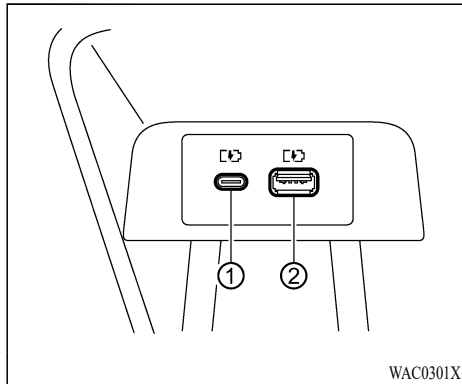

- ① Type-C port
- ② Type-A port

USB (Universal Serial Bus) CHARGING OUTLET (if so equipped)

The USB charging outlet is located on the back of the center console box.

The USB charging outlet can be used only for charging an external device.

Connect a USB device into the connector. Charging will start automatically.

The maximum output of each port is:

- ① Type-C port: 5 volt, 15W, 3A

- ② Type-A port: 5 volt, 12W, 2.4A

The external device will be charged continuously while the ignition switch is in the ACC or ON position.

Do not charge many devices at the same time by using a multi-plug adapter.

Do not allow water or any liquid to contact the outlet. If liquid splashed on the charging port or the charging port is clogged, it is recommended to contact an authorized Mitsubishi Motors dealer.

Some mobile devices cannot be charged depending on their specifications.

CAUTION

- Using charging connectors without engine running may cause the vehicle battery discharge.
- Before using the USB charging outlet, be sure the charging port is not clogged. If the charging port is clogged, it can be a cause of short-circuit and the connected device and the charging port might be damaged.
- Do not force a USB device into the connector. Inserting the USB device tilted or up-side-down into the connector may damage the connector. Make sure that the USB device is connected correctly into the connector.

- Do not use a reversible USB cable. Using the reversible USB cable may damage the connector.

WIRELESS CHARGER (if so equipped)

The wireless charger is located on the lower part of the instrument panel. Lay the smartphone on the pad of the wireless charger. Charging will start automatically. The smartphone will be charged continuously while the ignition switch is in the ON position.

WARNING

- Never put metallic materials between the wireless charger and a smartphone.
- Those who use a pacemaker or other medical equipment should contact the electric medical equipment manufacturer for the possible influences before use.
- Never put cloth over the smartphone during charging process.
- Never charge a smartphone when it is wet.
- Never put metallic materials or small goods such as a cigarette lighter.
- Never put F.A.S.T.-key near the wireless charger.

CAUTION

- Do not put an RFID/NFC card between the wireless charger and a smartphone. This could cause data corruption in the card.
- Do not use the wireless charger with dust accumulated or dirt on the pad.
- Do not hit the surface of the wireless charger.

Wireless charger Indicator

The indicator will illuminate in orange when the charging process is started.

When the charging has completed, the indicator illuminates in green.

If a malfunction occurs or the charging process has stopped, the indicator will blink in orange.

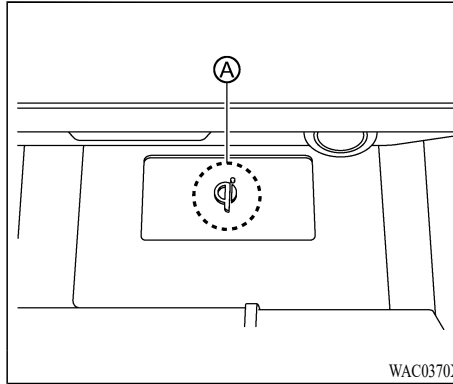

Operation of the wireless charger

To use the wireless charger, it is necessary that the coil in the charging pad aligns with the coil in your smartphone. The most efficient area for charging is just on the "Qi" logo . Place the coil of your smartphone in the charging pad, targeting on the "Qi" logo. Because the location of the coil varies depending on the smartphone, you will need to try and find the area that suits your smartphone.

Because some smartphone cases or accessories may adversely affect charging, remove them before wireless charging.

Turn off the vibration function of the smartphone before wireless charging.

NOTE:

- Only a Qi compatible smartphone can be used.
- The smartphone may be warmed during charging process and the charging may stop by the protection function of the wireless charger. This is not a malfunction. If this occurs, restart charging after the smartphone cooled down.
- The wireless charging process may be stopped by the status of the smartphone (battery temperature, etc.).
- If a radio noise interference occurs during charging process, put the smartphone's coil position onto the center ("Qi" logo) position of the wireless charger.
- The wireless charging process will stop during process of searching the F.A.S.T.-key.
- The wireless charging process will not be started when a USB (Universal Serial Bus) cable is connected to the smartphone. The indicator may illuminate in orange or blink if the smartphone is put on the wireless charger with a USB cable connected. However, charging is not performed.
- Depending on the type of the smartphone, the indicator may remain illuminated in orange even when the charging

process has been completed.

FCC ID: BEJWC500MNM

IC: 2703H-WC500MNM

This device complies with part 15 of the FCC Rules and RSS-Gen of IC Rules.

Operation is subject to the following two conditions:

- (1) This device may not cause harmful interference, and**
- (2) This device must accept any interference received, including interference that may cause undesired operation.**

Changes or modifications not expressly approved by the party responsible for compliance could void the user's authority to operate the equipment.

RF Radiation Exposure Statement: This equipment complies with FCC RF Radiation exposure limits set forth for an uncontrolled environment.

This device and its antenna must not be co-located or operating in conjunction with any other antenna or transmitter.

This equipment should be installed and operated with a minimum distance of 15cm between the radiator and your body.

ISED Compliance Statement

This device complies with RSS-Gen of IC Rules

Operation is subject to the following two conditions:

- (1) This device may not cause harmful interference, and**
- (2) This device must accept any interference received, including interference that may cause undesired operation.**

Changes or modifications made to this device, not expressly approved by LG Vehicle Components Company, will void the user's authority to operate the equipment.

ISED RF Radiation Exposure Statement: This equipment complies with ISED RF Radiation exposure limits set forth for an uncontrolled environment. This device and its antenna must not be co-located or operating in conjunction with any other antenna or transmitter. This equipment should be installed to operate with a minimum distance of 15cm between the radiator and the end-user's body and arms.

IDéclaration d'avertissement ISED

Son fonctionnement est soumis aux deux conditions suivantes:

- (1) Cet appareil ne doit pas provoquer d'interférences nuisibles, et**

- (2) Cet appareil doit accepter toute interference recue, y compris les interferences pouvant entrainer un fonctionnement indésirable.**

Les changements ou modifications non expressément approuvés par LG Vehicle Components Company pourraient annuler l'autorité de l'utilisateur à utiliser l'équipement.

Déclaration d'exposition aux radiations RF de l'ISED: Cet équipement est conforme aux limites d'exposition aux rayonnements RF de l'ISED définies pour un environnement non contrôlé. Cet appareil et son antenne ne doivent pas être situés ou fonctionner conjointement avec une autre antenne ou un autre émetteur.

Cet équipement doit être installé pour fonctionner avec une distance minimale de 15cm entre le radiateur et le corps de l'utilisateur final.

EMERGENCY CALL SYSTEM (e-CALL) (if so equipped)

EMERGENCY SUPPORT

MITSUBISHI CONNECT provide various services to support dealing with emergencies of the subscribed vehicle and the driver.

For example, in case of an illness or serious injury, you can seek support by pushing the in-vehicle SOS switch and connecting to the MITSUBISHI CONNECT Response Center. The MITSUBISHI CONNECT Response Center can specify the location of the vehicle via GPS, and the information will be sent to the police or other agencies as needed.

For information about other MITSUBISHI CONNECT emergency support related services, contact the MITSUBISHI CONNECT Customer Support line at 1-888-564-1411 (For U.S.) or 1-888-576-4878 (For Canada), or refer to the MITSUBISHI CONNECT website <https://www.mitsubishi-motors.com/en/products/connect>.

WARNING

- Please note that the Automatic Collision Notification service and Emergency Call function cannot be used in the following conditions:
 - Emergency functions and services will not be available without a paid subscription to

MITSUBISHI CONNECT.

- The MITSUBISHI CONNECT network system is disabled.
 - The vehicle moves outside the service area where the TCU (Telematics Control Unit) is connected to the system.
 - The vehicle is outside the area where the cellular network service is receivable.
 - The vehicle is in a location with poor signal reception such as tunnels, underground parking garages, behind buildings or in mountainous areas.
 - The line is busy.
 - The TCU (Telematics Control Unit) or other systems of your vehicle are not working properly.
 - It may not be possible to make an emergency call depending on the severity of a collision and/or emergency.
- Park the vehicle in a safe location and set the parking brake before operating the SOS switch.

- Only use this service in case of an emergency. There may be a penalty for inappropriate use of the service.
- Radio waves could adversely affect electric medical equipment. Individuals who use a pacemaker should contact the device manufacturer regarding any possible effects before using the system.
- The TCU (Telematics Control Unit) antenna is installed inside the upper central part of the instrument panel. An occupant should not get any closer to the antenna than specified by the pacemaker manufacturer. The radio waves from the TCU antenna may adversely affect the operation of the pacemaker while using the MITSUBISHI CONNECT.

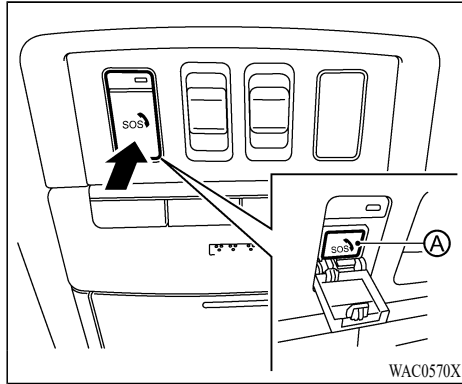

Making an emergency call

The SOS switch is located near the map light.

1. Push the cover to expose the SOS switch ④.
2. Push the SOS switch to make an emergency call.
3. When the line is connected, speak to the Response Specialist.

If you want to cancel the emergency call, push and hold the SOS switch for a few seconds.

NOTE:

- After the SOS switch is pushed, it may take some time until the system initiates connection, depending on the technical environment and whether the TCU (Tele-

matics Control Unit) is being used by other services.

- An indicator light on the SOS switch shows the readiness of the emergency support system. If the indicator light is not illuminated, pushing the SOS switch does not connect your vehicle to the Response Specialist.
The indicator light blinks while connected to the MITSUBISHI CONNECT Response Center.
- Even when the indicator light is illuminated, connection to the MITSUBISHI CONNECT Response Center may not be possible. If this occurs in an emergency situation, contact the authorities by other means.
- To avoid disconnecting the line, keep the engine running during an emergency call, if it is safe to do so.

STORAGE

CUP HOLDERS

CAUTION

- Avoid abrupt starting and braking when the cup holder is being used to prevent spilling the drink. If the liquid is hot, it can scald you or your passenger.
- Use only soft cups in the cup holder. Hard objects can injure you in an accident.

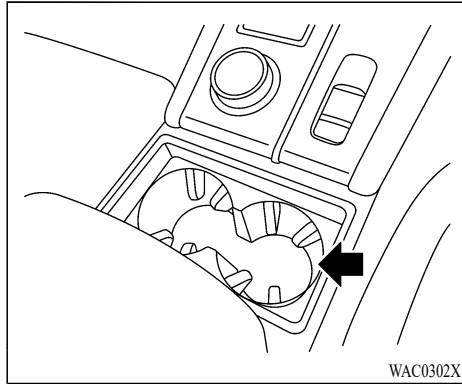

Center console

Front

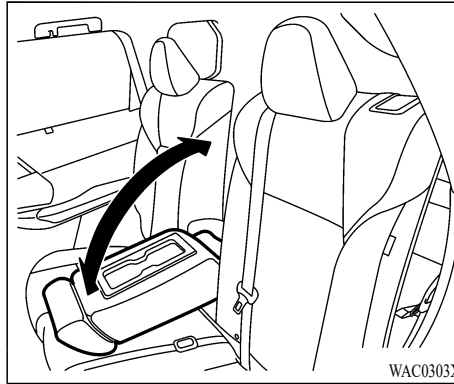

Second row seat

The second row seat cup holders are located in the second row seat fold-down armrest.

SOFT BOTTLE HOLDERS

! CAUTION

- Do not use bottle holder for any other objects that could be thrown about in the vehicle and possibly injure people during sudden braking or an accident.
- Do not use bottle holder for open liquid containers.

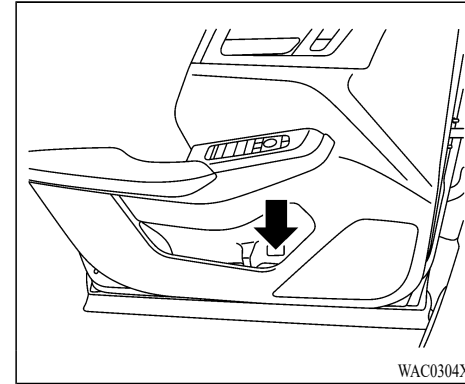

Door (front and rear)

LUGGAGE COMPARTMENT

! CAUTION

- Do not place cargo higher than the seat-backs. In a sudden stop or collision, unsecured cargo could cause personal injury.

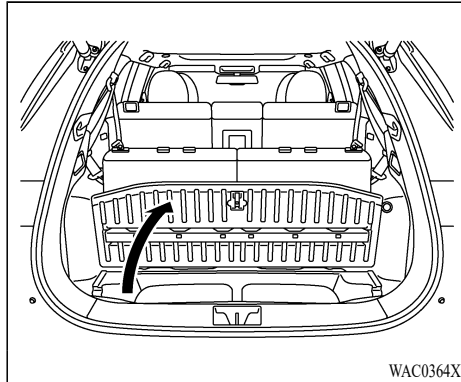

WAC0364X

Luggage under space

To use the luggage under space, pull up the luggage floor board. The luggage under space can be used to store the head restraints of the third row seats. For additional information, refer to “Third row seats” (P.1-9).

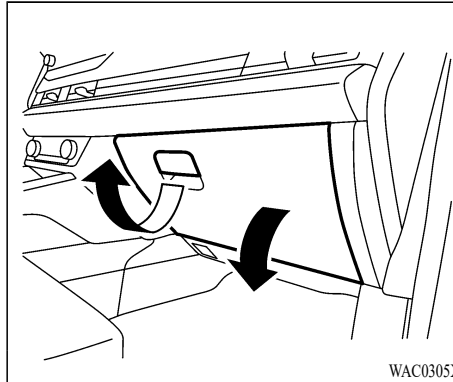

WAC0305X

GLOVE BOX



WARNING

Keep glove box lid closed while driving to help prevent injury in an accident or a sudden stop.

To open the glove box, pull the handle.

To close, push the lid in until the lock latches. The glove box light illuminates when the headlight switch is turned on.

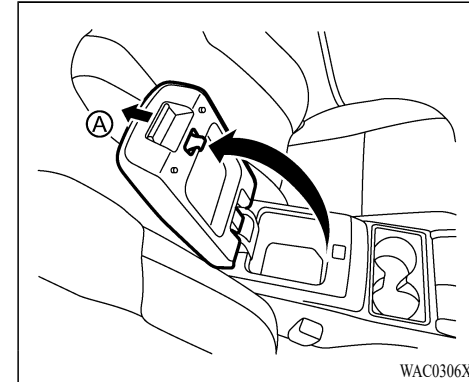

WAC0306X

CONSOLE BOX

To open the console box lid, push up the knob Ⓐ and pull up the lid.

To close, push the lid down until the lock latches.

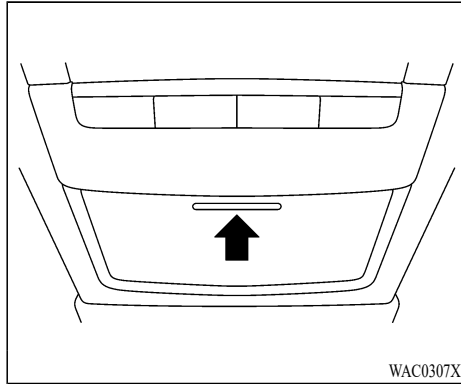

SUNGLASSES HOLDER

WARNING

Keep the sunglasses holder closed while driving to avoid obstructing the driver's view and to help prevent an accident.

CAUTION

- Do not use for anything other than sunglasses.

- Do not leave sunglasses in the sunglasses holder while parking in direct sunlight. The heat may damage the sunglasses.

The sunglasses holder is located between the left and right sunvisors.

To open the sunglasses holder, push and release. Only store one pair of sunglasses in the holder.

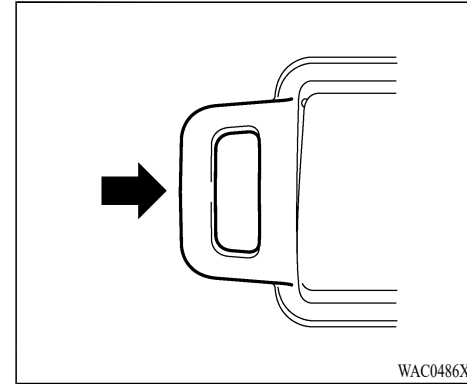

CARD HOLDER

The card holder is located on the sunvisor. Slide a card in the card holder.

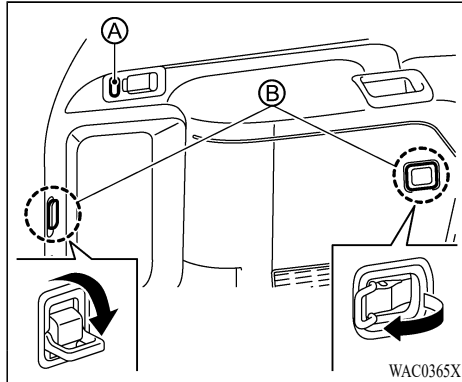

LUGGAGE HOOKS

The luggage hooks A B are located as shown. To use the hooks B, pull it as illustrated. Do not put heavy load on the hooks B when they are in use to prevent hooks are broken.

WARNING

- Always make sure that the cargo is properly secured. Use the suitable ropes and hooks.
- Unsecured cargo can become dangerous in an accident or sudden stop.

- Do not apply a total load of more than 6.6 lb (3 kg) for hook A or 44 lb (20 kg) for hook B to a single hook.

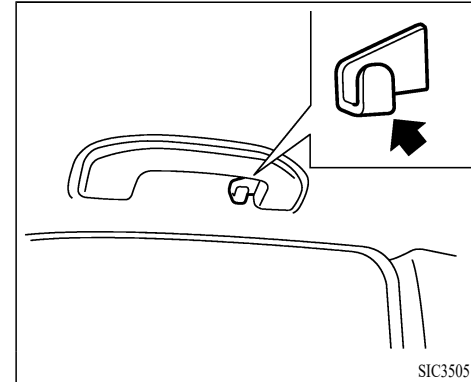

COAT HOOKS

The coat hooks are located above the rear side windows.

WARNING

Do not put a hanger or any heavy or pointed object on the coat hook. If the curtain airbag was activated, any such item could be propelled away with great force and could prevent the curtain airbag from inflating correctly. Hang clothes directly on the coat hook (without using a hanger). Make sure there are no heavy or sharp objects in the pockets of clothes that you hang on the coat hook.

CAUTION

Do not apply a total load of more than 2 lb (1 kg) to the hook.

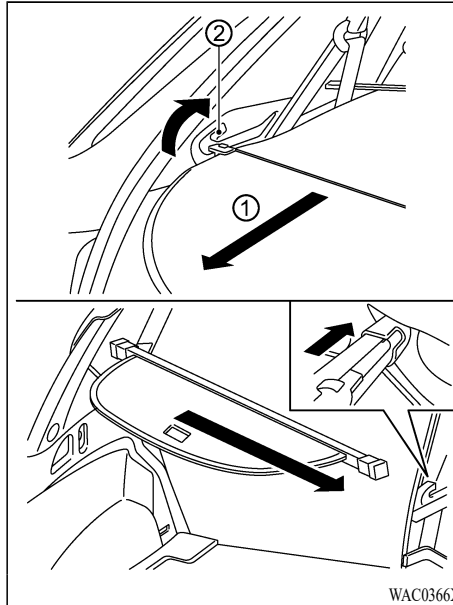

TONNEAU COVER (if so equipped)

The tonneau cover keeps the luggage compartment contents hidden from the outside.

To use the tonneau cover, pull it out ① and insert both sides to the guide ②.

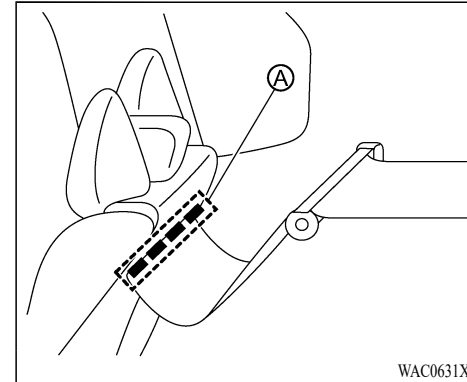

To fully cover the luggage area, affix the fasteners A on the front cover to the back of the second row seats.

To remove the tonneau cover, stow the cover and push it at the right end, pull up the right end of the stored tonneau cover from the holder located near by the rear pillar, then take it out from the cargo area.

WARNING

- Never put anything on the tonneau cover, no matter how small. Any object on it could cause an injury in an accident or sudden stop.

- Do not leave the tonneau cover in the vehicle with it disengaged from the holder.
- The child restraint top tether strap may be damaged by contact with the tonneau cover or items in the cargo area. Remove the tonneau cover from the vehicle or secure it in the cargo area. Also secure any items in the cargo area. Your child could be seriously injured or killed in a collision if the top tether strap is damaged.

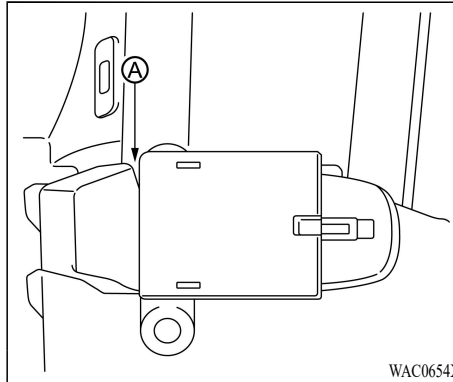

WAC0654X

Storing tonneau cover

The tonneau cover can be stored in the luggage under space when not in use.

Raise the luggage floor board and store the tonneau cover.

Insert the front cover in the space **A** as illustrated.

ROOF RAIL (if so equipped)

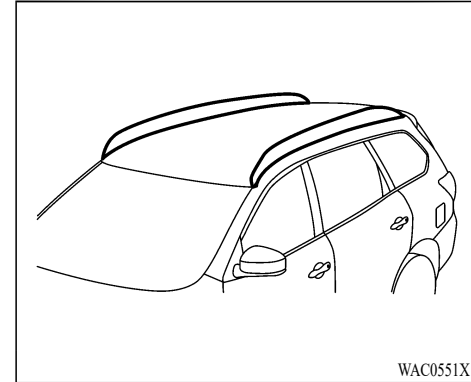

WAC0551X

Do not apply any load directly to the roof side rails. Cross bars must be installed before applying load/cargo/luggage to the roof of the vehicle. Mitsubishi Motors genuine accessory cross bars are available through an authorized Mitsubishi Motors dealer. It is recommended that you visit an authorized Mitsubishi Motors dealer for additional information.

The service load capacity for the roof side rails is 176 lb (80 kg), however do not exceed the accessory cross bars load capacity.

Be careful that your vehicle does not exceed the Gross Vehicle Weight Rating (GVWR) or its Gross Axle Weight Rating (GAWR front and rear). The GVWR and GAWR are located on the F.M.V.S.S. or C.V.M.S.S. certification label

(located on the driver's door pillar). For additional information regarding GVWR and GAWR, refer to "Vehicle loading information" (P.10-15).

WARNING

- Always install the cross bars onto the roof side rails before loading cargo of any kind. Loading cargo directly onto the roof side rails or the vehicle's roof may cause vehicle damage.
- Drive extra carefully when the vehicle is loaded at or near the cargo carrying capacity, especially if the significant portion of that load is carried on the cross bars.
- Heavy loading of the cross bars has the potential to affect the vehicle stability and handling. Drive carefully and avoid sudden or unusual handling maneuvers.
- Roof rail cross bars should be evenly distributed.
- Do not exceed maximum roof rail cross bars load.
- Properly secure all cargo with ropes or straps to help prevent it from sliding or shifting. In a sudden stop or collision, unsecured cargo could cause personal injury.

WINDOWS

POWER WINDOWS

WARNING

- Make sure that all passengers have their hands, etc. inside the vehicle while it is in motion and before closing the windows. Use the window lock to prevent unexpected use of the power windows.
- To help avoid risk of injury or death through unintended operation of the vehicle and or its systems, including entrapment in windows or inadvertent door lock activation, do not leave children, people who require the assistance of others or pets unattended in your vehicle. Additionally, the temperature inside a closed vehicle on a warm day can quickly become high enough to cause a significant risk of injury or death to people and pets.

NOTE:

If the power window does not close completely when driving, slow down the vehicle speed and open and close the power window.

The power windows operate when the ignition switch is in the ON position, or for about 45 seconds after the ignition switch is placed in the OFF position. If the driver's or front passenger's door is opened during this period of about 45 seconds, power to the windows is canceled.

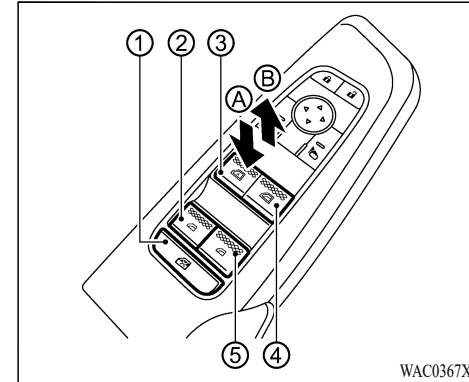

- ① Window lock button
- ② Rear left passenger side window
- ③ Driver side window
- ④ Front passenger side window
- ⑤ Rear right passenger side window

Main power window switch (driver's side)

To open or close the window, push down Ⓐ or pull up Ⓑ the switch and hold it. The main switch (driver side switches) will open or close all the windows.

Locking passengers' windows

When the lock button ① is pushed in, only the driver side window can be opened or closed. Push it in again to cancel.

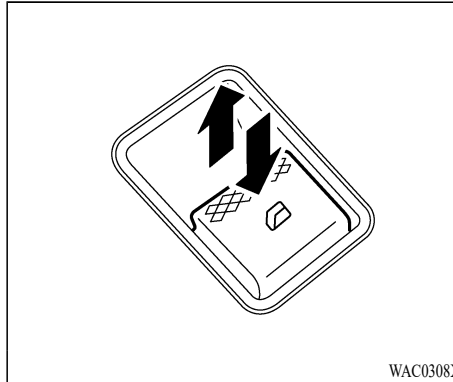

Passenger side power window switch

The passenger side switch will open or close only the corresponding window. To open or close the window, push down or pull up the switch and hold it.

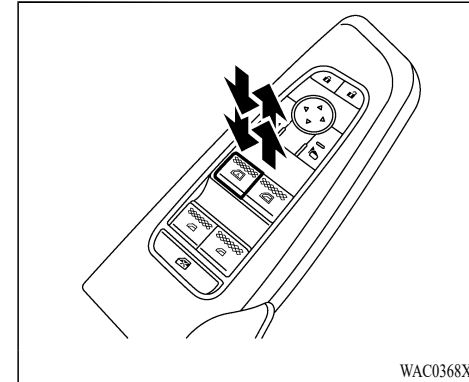

Example

Automatic operation (if so equipped)

The automatic operation is available for the switch that has an  mark on its surface.

To fully open or close the window, completely push down or pull up the switch and release it; the switch need not be held. The window will automatically open or close all the way. To stop the window, just push or lift the switch in the opposite direction.

A light push or pull on the switch will cause the window to open or close until the switch is released.

Auto-reverse function (if so equipped)

WARNING

There are some small distances immediately before the closed position which cannot be detected. Make sure that all passengers have their hands, etc., inside the vehicle before closing the window.

If the control unit detects something caught in the window as it is closing, the window will be immediately lowered.

The auto reverse function can be activated when the window is closed by automatic operation when the ignition switch is in the ON position or for 45 seconds after the ignition switch is placed in the OFF position.

Depending on the environment or driving conditions, the auto reverse function may be activated if an impact or load similar to something being caught in the window occurs.

If the windows do not close automatically

If the power window automatic function (closing only) does not operate properly, perform the following procedure to initialize the power window system.

1. Start the engine.
2. Close the door.
3. After starting the engine, open the window completely by operating the power window switch.
4. Pull the power window switch and hold it to close the window, and then hold the switch more than 3 seconds after the window is closed completely.
5. Release the power window switch. Operate the window by the automatic function to confirm the initialization is complete.

WARNING

When the auto-reverse function is canceled, the window will not automatically reverse even if the control unit detects an obstacle. Make sure that all passengers have their hands, etc. inside the vehicle before closing the windows.

If the power window automatic function does not operate properly after performing the

procedure above, it is recommended you have your vehicle checked by an authorized Mitsubishi Motors dealer.

SUNROOF (if so equipped)

WARNING

- In an accident you could be thrown from the vehicle through an open sunroof. Always use seat belts and child restraints.
- Do not allow anyone to stand up or extend any portion of their body out of the sunroof opening while the vehicle is in motion or while the sunroof is closing.

CAUTION

- Remove water drops, snow, ice or sand from the sunroof before opening.
- Do not place any heavy object on the sunroof or surrounding area.

The sunroof and sunshade operate when the ignition switch is in the ON position, or for about 45 seconds after the ignition switch is placed in the OFF position. If the driver's or front passenger's door is opened during this period of about 45 seconds, power to the sunroof and sunshade is canceled.

2-78 Instruments and controls

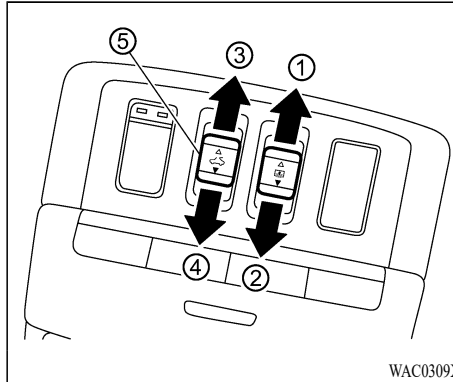

POWER PANORAMIC SUNROOF AND SUNSHADE

Sliding sunshade and sunroof

When the sunshade switch is pushed to the OPEN position ①, the sunshade opens fully. When the sunroof switch is pushed to the OPEN position ③, the sunroof opens to the comfort mode position. When the switch is pushed again, the sunroof opens fully.

Depending on the position of the sunshade, the sunshade will open together with the sunroof.

When the sunroof switch is pushed to the CLOSE position ④, the sunroof will automatically close. When the sunshade switch is pushed

to the CLOSE position ②, sunshade will close. Before the sunshade is fully closed, the sunroof must be completely closed.

To stop the sunshade or sunroof during the operation, push the sunroof switch to either of the OPEN ①, ③, CLOSE ②, ④ or UP ⑤ position.

Tilting sunroof

To tilt up the sunroof, push the sunroof switch to the up position ⑤ when the sunroof is fully closed.

To tilt down the sunroof, push the switch to the CLOSE position ④.

Comfort mode

This is the position used when driving with the sunroof open. When driving with the sunroof fully open, wind noise may be very loud. Use the comfort mode position when driving.

Auto-reverse function

WARNING

There are some small distances just before the closed position which cannot be detected. Make sure that all passengers have their hands, etc. inside the vehicle before closing the sunroof and sunshade.

The auto-reverse function enables the sunroof and sunshade to automatically reverse when something is caught in the sunroof and sunshade as it is closing. When the control unit detects an obstacle, the sunroof and sunshade will open immediately.

Depending on the environment or driving conditions, the auto-reverse function may activate if an impact or load similar to something being caught in the sunroof and sunshade occurs.

If the auto-reverse function activates consecutively or the battery is discharged, the sunroof and sunshade may not close properly. In this case, push and hold the switch to the CLOSE position ④ to close the sunroof.

If the sunroof does not operate

If the sunroof and sunshade do not operate properly, perform the following procedure to initialize the operation system.

1. Push and hold the switch in direction ⑤.
2. The sunroof will move to the tilt up position and the sunshade will move to the fully closed positions in small increments.

NOTE:

If the sunroof and sunshade are both open, the sunroof will move to the fully closed position, and then the sunshade will move to the fully closed position.

3. When the sunroof have stopped in the tilt up position and the sunshade have stopped in the fully closed position, release the switch. (The resetting procedure is finished.)

NOTE:

Do not release the switch until the resetting procedure is finished. If you release the switch, the resetting mode will be cancelled. To perform the resetting procedure again, repeat the procedure from step 1.

WARNING

The driver is always responsible for operation of the sunroof including all passenger's operation. Failure to follow the warnings and instructions for proper use of the sunroof could result in serious injury or death.

- Do not let children operate the sunroof. Improper operation by children may cause an accident. If a child or other person is caught in the sunroof, it could cause serious injury.
- To help avoid risk of injury or death through unintended operation of the sunroof, Place the ignition switch in the OFF position, do not leave children and F.A.S. T.-key inside the vehicle when you leave the vehicle.

- Do not activate the auto-reverse function intentionally. If hands or face etc. get caught in the sunroof, it could cause serious injury.

CAUTION

- Do not place objects (such as newspapers, handkerchiefs, etc.) on the sunshade when it is extending or retracting causing improper operation or damage to the sunshade.
- Do not push the sunshade arm with your hands, etc., as this may deform it. Improper operation or damage to the sunshade may result.
- Do not put any object into the sunshade inlet port as this may result in improper operation or damage the sunshade.
- Do not hang any object on the arm rail as this may result in improper operation or damage the sunshade.
- Do not forcefully pull the sunshade. Doing so may elongate the sunshade. Improper operation or damage to the sunshade may result.

INTERIOR LIGHTS

CAUTION

- Do not leave the light switch on when the engine is not running for extended periods of time to prevent the battery from being discharged.
- Turn off the lights when you leave the vehicle.

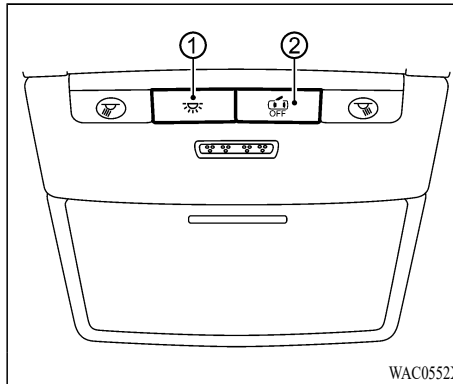

INTERIOR LIGHT SWITCH

- ① The interior light can be turned ON regardless of door position. The light will go off after a period of time unless the ignition switch is placed in the "ON" position when any door is opened.
- ② The interior lights can be set to operate when the doors are opened. To turn off the interior lights when a door is open, push the switch, the interior lights will not illuminate, regardless of door position. The lights will go off when the ignition switch is placed in the "ON" position, or the driver's door is closed and locked.

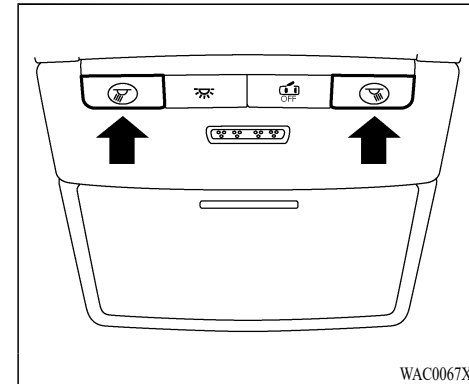

MAP LIGHTS

Push the button to turn the map lights on. To turn them off, push the button again.

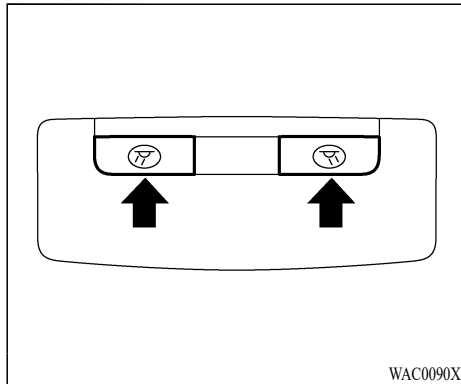

DOMES LIGHTS (if so equipped)

The dome lights are located on the ceiling above the second row seats. Push the button to turn the dome lights on. To turn them off, push the button again.

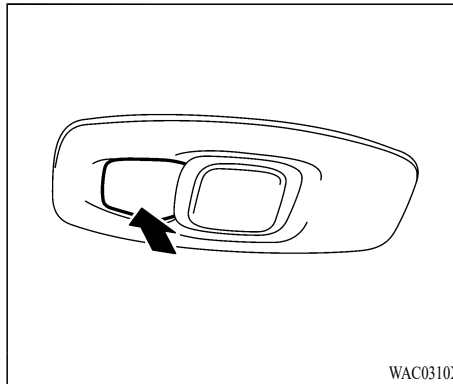

REAR PERSONAL LIGHTS (if so equipped)

To turn the rear personal lights on, push the button. To turn them off, push the button again.

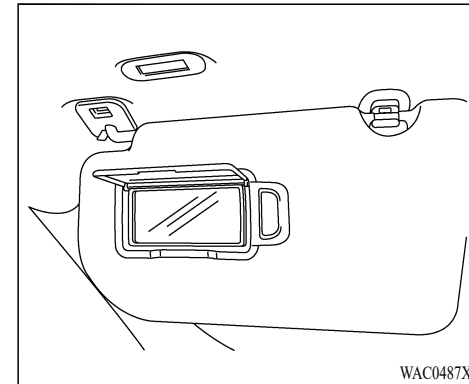

VANITY MIRROR LIGHT

The vanity mirror light is located on the ceiling above the vanity mirror.

The vanity mirror light will turn on when the cover on the vanity mirror is opened.

When the cover is closed, the light will turn off.

The lights will also turn off after a period of time when the lights remain illuminated to prevent the battery from becoming discharged.

CARGO ROOM LIGHT

The cargo room light illuminate when the liftgate is opened. When the liftgate is closed, the lights will turn off.

The light will also turn off after a period of time when the light remains illuminated after the ignition switch has been pushed to the OFF position to prevent the battery from becoming discharged.

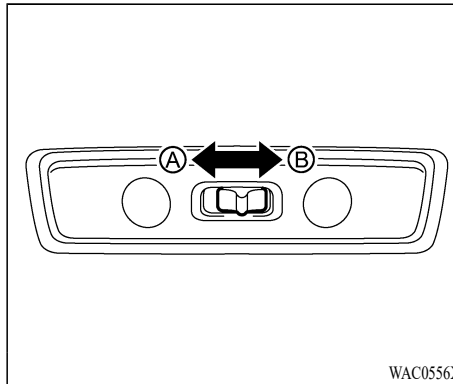

LIFTGATE LIGHT

To turn the liftgate light on, slide the switch to Ⓐ. To turn them off, slide the switch to Ⓑ.

3 Pre-driving checks and adjustments

Keys	3-2	Liftgate	3-20
Free-hand Advanced Security		Operating manual liftgate	3-21
Transmitter (F.A.S.T.-key)	3-2	Operating power liftgate (if so equipped)	3-22
Doors	3-4	Operating the power liftgate using the hands-free	
Locking with key	3-4	access (if so equipped)	3-25
Locking with inside lock knob	3-4	Liftgate close and lock function	3-26
Locking with power door lock switch	3-6	Liftgate release lever	3-27
Automatic door locks	3-6	Height memory function	3-27
Child safety rear door lock	3-6	Fuel filler door	3-28
Free-hand Advanced Security		Opening the fuel filler door	3-28
Transmitter (F.A.S.T.-key)	3-7	How to refuel	3-29
F.A.S.T.-key operating range (models with		Tilt/telescopic steering	3-31
request switch)	3-9	Tilt or telescopic operation	3-32
Door locks/unlocks precaution (models with		Sunvisors	3-32
request switch)	3-9	Pull-up type sunshade (rear door) (if so equipped)	3-33
F.A.S.T.-key operation	3-10	Mirrors	3-33
Battery saver system	3-12	Inside mirror	3-33
Warnings and audible reminders	3-12	Door mirrors	3-34
Troubleshooting guide	3-13	Vanity mirror	3-37
How to use remote keyless entry function	3-15	Driver memory settings (if so equipped)	3-37
Hood	3-19	Memory storage function	3-38
		Entry/Exit function	3-39
		System operation	3-39



KEYS

The key number is stamped on the key number tag as indicated in the illustration. Make a record of the key number and store the key and key number tag in separate places, so that you can order a key from your authorized Mitsubishi Motors dealer in the event the original keys are lost.

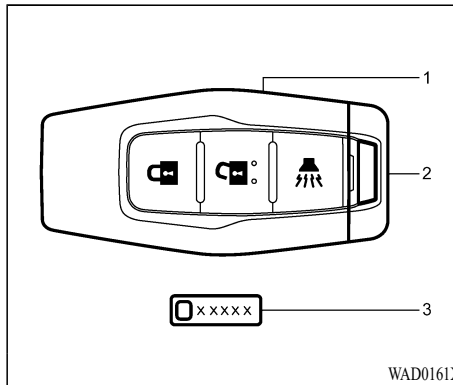

Type A

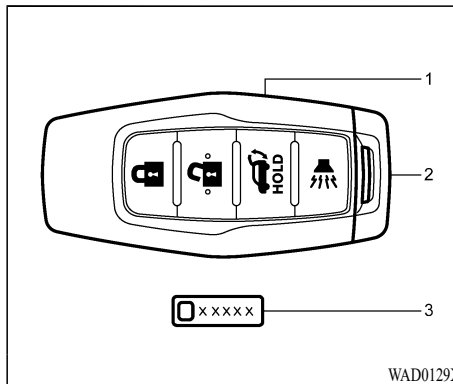

Type B

1. F.A.S.T.-key (2 sets)
2. Emergency key (inside F.A.S.T.-key) (2 sets)
3. Key number tag

FREE-HAND ADVANCED SECURITY TRANSMITTER (F.A.S.T.-key)

Your vehicle can only be driven with the Free-hand Advanced Security Transmitter (F.A.S.T.-key) which are registered to your vehicle's F.A.S.T.-key components and Anti-theft engine immobilizer components. As many as 4 F.A.S.T.-keys can be registered and used with one vehicle.

To prevent vehicle theft, take your vehicle and the remaining F.A.S.T.-keys to an authorized Mitsubishi Motors dealer to have the ID codes reprogrammed.

Replacement F.A.S.T.-keys

Only the F.A.S.T.-keys that have been programmed to the vehicle's electronics can be used to start the vehicle.

If you lose the F.A.S.T.-key, you can order a F.A.S.T.-key from your authorized Mitsubishi Motors dealer by referring to the key number.

3-2 Pre-driving checks and adjustments

CAUTION

- Be sure to carry the F.A.S.T.-key with you when driving. The F.A.S.T.-key is a precision device with a built-in transmitter. To avoid damaging it, please note the following.
 - The F.A.S.T.-key is water resistant; however, wetting may damage the F.A.S.T.-key. If the F.A.S.T.-key gets wet, immediately wipe until it is completely dry.
 - Do not bend, drop or strike it against another object.
 - If the outside temperature is below 14°F (-10°C) degrees, the battery of the F.A.S.T.-key may not function properly.
 - Do not place the F.A.S.T.-key for an extended period in a place where temperatures exceed 140°F (60°C).
 - Do not change or modify the F.A.S.T.-key.
 - Do not use a magnet key holder.
 - Do not place the F.A.S.T.-key near an electric appliance such

as a television set, personal computer, cellular phone or wireless charger.

- Do not allow the F.A.S.T.-key to come into contact with water or salt water, and do not wash it in a washing machine or ultrasonic cleaner. This could affect the system function.
- If an F.A.S.T.-key is lost or stolen, Mitsubishi Motors recommends erasing the ID code of that F.A.S.T.-key. This will prevent the F.A.S.T.-key from unauthorized use to unlock the vehicle. For information regarding the erasing procedure, it is recommended you visit an authorized Mitsubishi Motors dealer.

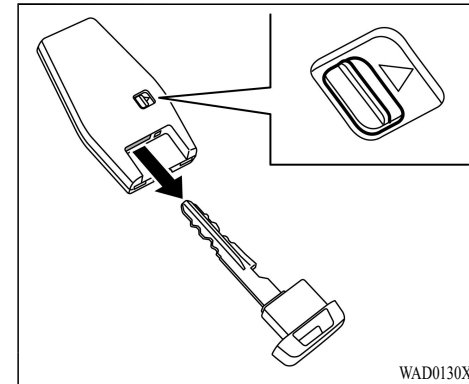

Emergency key

To remove the emergency key, release the lock knob at the back of the F.A.S.T.-key.

To install the emergency key, firmly insert it into the F.A.S.T.-key until the lock knob returns to the lock position.

Use the emergency key to lock or unlock the doors. (See “Doors” (P.3-4).)

CAUTION

Always carry the emergency key installed in the F.A.S.T.-key.

DOORS

WARNING

- Always have the doors locked while driving. Along with the use of seat belts, this provides greater safety in the event of an accident by helping to prevent persons from being thrown from the vehicle. This also helps keep children and others from unintentionally opening the doors, and will help keep out intruders.
- When closing a door, make sure that the door is fully closed and the door-ajar warning display goes out on the information screen on the multi-information display. If the door is ajar it could open while driving and cause an accident.
- Before opening any door, always look for and avoid oncoming traffic.
- To help avoid risk of injury or death through unintended operation of the vehicle and or its systems, including entrapment in windows or inadvertent door lock activation, do not leave children, people who require the assistance of others or pets unattended in your vehicle. Additionally, the temperature inside a closed vehicle on a warm day can quickly become high enough to cause a significant risk of injury or death to people and pets.

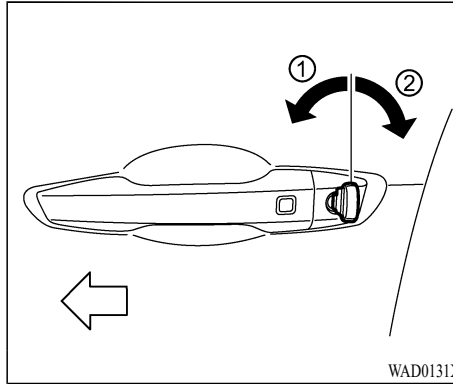

LOCKING WITH INSIDE LOCK KNOB

When locking the door without a key, be sure not to leave the key inside the vehicle.

LOCKING WITH KEY

To lock the driver's door, turn the driver's door key cylinder to the front of the vehicle ①.

To unlock the driver's door, turn the driver's door key cylinder to the rear of the vehicle ②.

To lock or unlock the other doors and the liftgate, use the Free-hand Advanced Security Transmitter (F.A.S.T.-key) function. (See "Free-hand Advanced Security Transmitter (F.A.S.T.-key)" (P.3-7).)

3-4 Pre-driving checks and adjustments

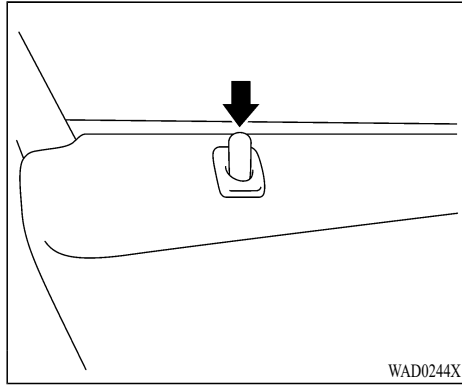

To lock the door, push down the inside lock knob.

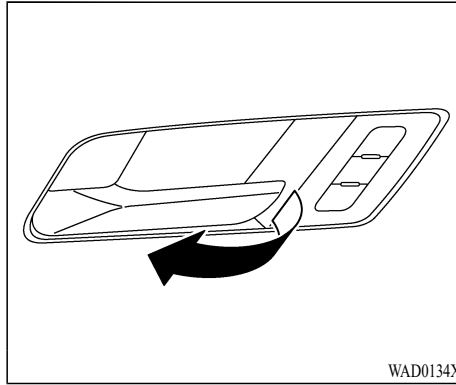

To unlock and open the driver's door, pull the door handle. To unlock and open other doors, pull once on the door handle to unlock it, and again to open it.

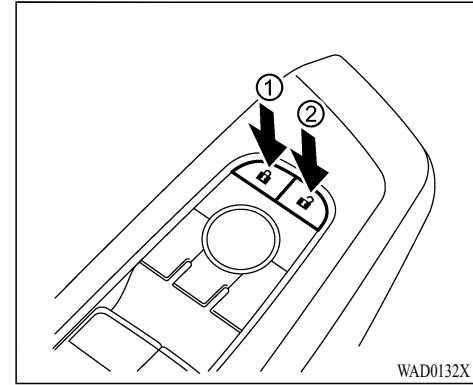

Driver's armrest

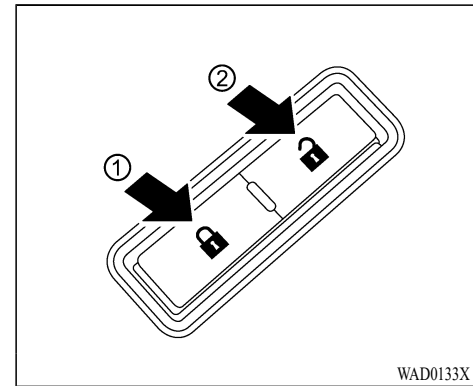

Passenger's armrest

Pre-driving checks and adjustments 3-5

LOCKING WITH POWER DOOR LOCK SWITCH

NOTE:

Repeated continuous operation between lock and unlock could activate the power door locking system's built-in protection circuit, and prevent the system from operating. If this occurs, wait approximately 1 minute before operating the power door lock switch.

Operating the power door lock switch (located on the driver's and front passenger's doors) will lock or unlock all the doors.

To lock the doors, push the power door lock switch ① with the driver's and front passenger's doors open, then close the door.

When locking the door this way, be sure not to leave the key inside the vehicle.

To unlock the doors, push the door unlock switch ②.

Lockout protection

Lockout protection function helps to prevent the keys from being accidentally locked inside the vehicle.

When the power door lock switch ① (driver's or front passenger's side) is pushed with the F.A.S.T.-key left in the vehicle and any door open, all doors will unlock automatically and a chime

will sound after the door is closed.

AUTOMATIC DOOR LOCKS

- All doors lock automatically when the vehicle speed reaches 9 MPH (15 km/h) or when the shift lever is moved out from the P (Park) position, if selected.
- All doors unlock automatically when the ignition switch is placed in the OFF position or when the shift lever is moved to the P (Park) position, if selected.

NOTE:

The Automatic door lock and unlock feature can be changed using the "Vehicle Settings" menu on the multi-information display. (See "Vehicle Settings" (P.2-26).)

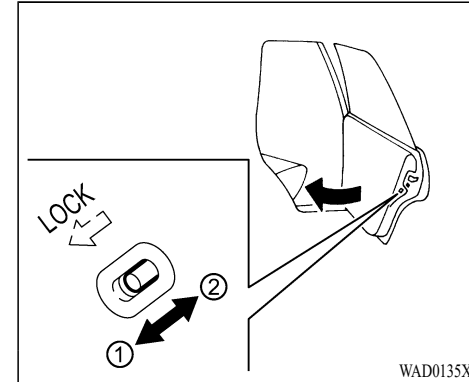

CHILD SAFETY REAR DOOR LOCK

Child safety rear door locks help prevent the rear doors from being opened accidentally, especially when small children are in the vehicle.

When the levers are in the lock position ①, the rear doors can be opened only from the outside.

To disengage, move the levers to the unlock position ②.

FREE-HAND ADVANCED SECURITY TRANSMITTER (F.A.S.T.-key)

WARNING

- Radio waves could adversely affect electric medical equipment. Those who use a pacemaker should contact the electric medical equipment manufacturer for the possible influences before use.
- The F.A.S.T.-key transmits radio waves when the buttons are pushed. The FAA advises that the radio waves may affect aircraft navigation and communication systems. Do not operate the F.A.S.T.-key while on an airplane. Make sure the buttons are not operated unintentionally when the unit is stored during a flight.

The Free-hand Advanced Security Transmitter (F.A.S.T.-key) can operate all the door locks using the remote keyless entry function or pushing the request switch (if so equipped) on the vehicle without taking the key out from a pocket or purse. The operating environment and/or conditions may affect the F.A.S.T.-key operation.

Be sure to read the following before using the F.A.S.T.-key.

CAUTION

- Be sure to carry the F.A.S.T.-key with you when operating the vehicle.
- Never leave the F.A.S.T.-key in the vehicle when you leave the vehicle.

The F.A.S.T.-key is always communicating with the vehicle as it receives radio waves. The F.A.S.T.-key transmits weak radio waves. Environmental conditions may interfere with the operation of the F.A.S.T.-key under the following operating conditions.

- When operating near a location where strong radio waves are transmitted, such as a TV tower, power station and broadcasting station.
- When in possession of wireless equipment, such as a cellular phone, transceiver, and CB radio.
- When the F.A.S.T.-key is in contact with or covered by metallic materials.
- When any type of radio wave remote control is used nearby.
- When the F.A.S.T.-key is placed near an electric appliance such as a personal computer.

- When the vehicle is parked near a parking meter.

In such cases, correct the operating conditions before using the F.A.S.T.-key function or use the emergency key.

Although the life of the battery varies depending on the operating conditions, the battery's life is approximately 2 years. If the battery is discharged, replace it with a new one.

Since the F.A.S.T.-key is continuously receiving radio waves, if the key is left near equipment which transmits strong radio waves, such as signals from a TV and personal computer, the battery life may become shorter.

For information regarding replacement of a battery, see "F.A.S.T.-key battery replacement" (P.8-20).

As many as 4 F.A.S.T.-keys can be registered and used with one vehicle. If you purchase another F.A.S.T.-keys, take your vehicle and all remaining F.A.S.T.-keys to your authorized Mitsubishi Motors dealer. For information about the purchase and use of additional F.A.S.T.-keys, it is recommended that you contact an authorized Mitsubishi Motors dealer.

Pre-driving checks and adjustments 3-7

CAUTION

- Do not allow the F.A.S.T.-key, which contains electrical components, to come into contact with water or salt water. This could affect the system function.
- Do not drop the F.A.S.T.-key.
- Do not strike the F.A.S.T.-key sharply against another object.
- Do not change or modify the F.A.S.T.-key.
- Wetting may damage the F.A.S.T.-key. If the F.A.S.T.-key gets wet, immediately wipe until it is completely dry.
- If the outside temperature is below 14°F (−10°C) degrees, the battery of the F.A.S.T.-key may not function properly.
- Do not place the F.A.S.T.-key for an extended period in an area where temperatures exceed 140°F (60°C).
- Do not attach the F.A.S.T.-key with a key holder that contains a magnet.
- Do not place the F.A.S.T.-key near equipment that produces a magnetic field, such as a TV, audio equipment, personal computers or cellular phone.

If an F.A.S.T.-key is lost or stolen, Mitsubishi Motors recommends erasing the ID code of that F.A.S.T.-key from the vehicle. This may prevent

3-8 Pre-driving checks and adjustments

Condition:

the unauthorized use of the F.A.S.T.-key to operate the vehicle. For information regarding the erasing procedure, it is recommended that you contact an authorized Mitsubishi Motors dealer.

The F.A.S.T.-key function can be disabled. For information about disabling the F.A.S.T.-key function, it is recommended that you contact an authorized Mitsubishi Motors dealer.

WARNING

- Individuals who use implantable pacemakers or implantable cardiovascular-defibrillators should keep away from the external and internal transmitters. The electromagnetic waves used in the F.A.S.T.-key may affect the operation of implantable pacemakers and implantable cardiovascular-defibrillators.
- Individuals using other electro-medical apparatus besides implantable pacemakers and implantable cardiovascular-defibrillators should check with the manufacturer of the apparatus to confirm the effect of the electromagnetic waves used by the F.A.S.T.-key. The electromagnetic waves may affect the operations of the electro-medical apparatus.

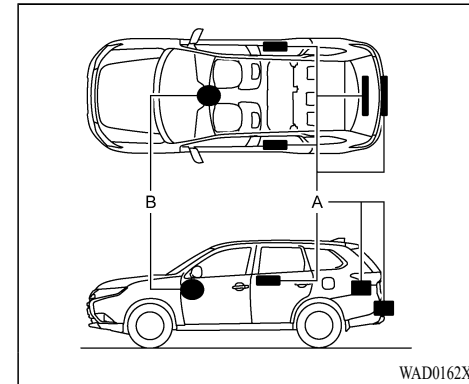

- A. LF antenna
- B. Ignition switch (with built-in transmitter)

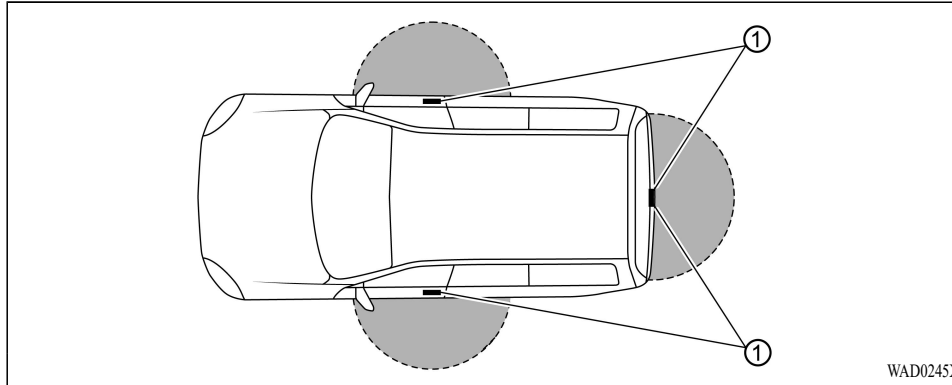

WAD0245X

F.A.S.T.-KEY OPERATING RANGE (models with request switch)

The F.A.S.T.-key functions can only be used when the F.A.S.T.-key is within the specified operating range from the request switch ①.

When the F.A.S.T.-key battery is discharged or strong radio waves are present near the operating location, the F.A.S.T.-key's operating range becomes narrower, and the F.A.S.T.-key may not function properly.

The operating range is within 2.3 feet (70 cm) from each request switch ①.

If the F.A.S.T.-key is too close to the door glass,

handle or rear bumper, the request switches may not function.

When the F.A.S.T.-key is within the operating range, it is possible for anyone who does not carry the F.A.S.T.-key to push the request switch to lock/unlock the doors including the liftgate.

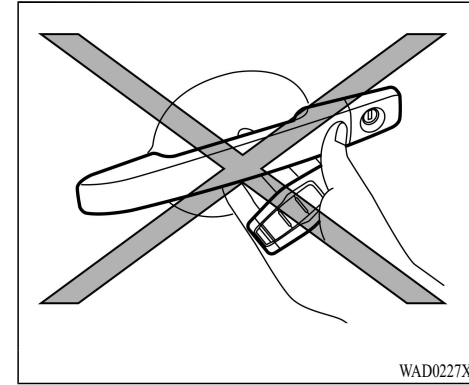

WAD0227X

DOOR LOCKS/UNLOCKS PRECAUTION (models with request switch)

- Do not push the door handle request switch with the F.A.S.T.-key held in your hand as illustrated. The close distance to the door handle will cause the F.A.S.T.-key to have difficulty recognizing that the F.A.S.T.-key is outside the vehicle.
- After locking with the door handle request switch, verify the doors are securely locked by testing them.
- To prevent the F.A.S.T.-key from being left inside the vehicle, make sure you carry the key with you and then lock the doors.

Pre-driving checks and adjustments 3-9

- Do not pull the door handle before pushing the door handle request switch. The door will be unlocked but will not open. Release the door handle once and pull it again to open the door.

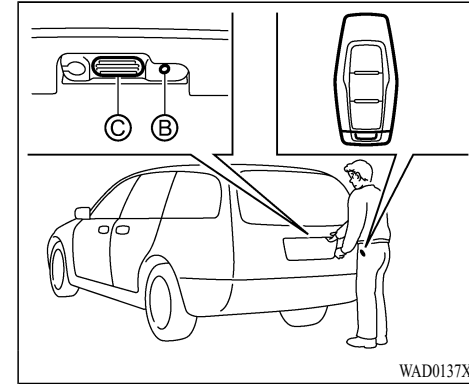
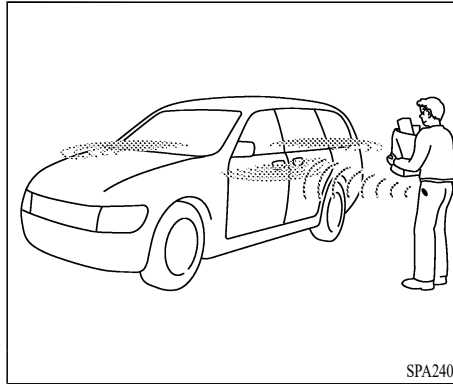

Example

F.A.S.T.-KEY OPERATION

You can lock or unlock the doors without taking the key out from your pocket or bag.

When you carry the F.A.S.T.-key with you, you can lock or unlock all doors by pushing the door handle request switch Ⓐ (if so equipped) or liftgate request switch Ⓑ (if so equipped) within the range of operation.

When you lock or unlock the doors, the hazard indicator will flash and the outside chime will sound as a confirmation. For details, see “Setting hazard indicator and horn mode” (P.3-18).

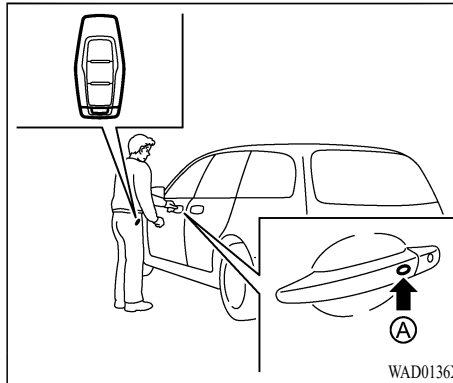

Example

3-10 Pre-driving checks and adjustments



Condition:

[Edit: 2021/ 2/ 10 Model: DG-D]

Welcome light function

When you unlock the doors or the liftgate, the parking lights and the tail lights will illuminate for a period of time. The welcome light function can be disabled. For information about disabling the welcome light function, see “Vehicle Settings” (P.2-26).

Locking doors (models with request switch)

1. Push the park button to shift to the P (Park) position. place the ignition switch in the OFF position and make sure you carry the F.A.S.T.-key with you.
2. Close all doors.
3. Push any door handle request switch  or the liftgate request switch  while carrying the F.A.S.T.-key with you.
4. All doors and the liftgate will lock.
5. The hazard indicator lights flash once and the outside chime sounds once.

NOTE:



- Request switches for all doors and the liftgate can be deactivated when the Ext. Door Switch setting is turned off in the Vehicle Settings of the multi-information display. For additional information, see “Vehicle Settings” (P.2-26).

- Doors do not lock with the door handle request switch while the ignition switch is not in the LOCK position.
- Doors do not lock with the door handle request switch with the F.A.S.T.-key inside the vehicle and a beep sounds to warn you.

CAUTION

- After locking the doors using the request switch, make sure that the doors have been securely locked by operating the door handles.
- When locking the doors using the request switch, make sure to have the F.A.S.T.-key in your possession before operating the request switch to prevent the F.A.S.T.-key from being left in the vehicle.
- The request switch is operational only when the F.A.S.T.-key has been detected.

Unlocking doors (models with request switch)

1. Push the door handle request switch  or the liftgate request switch  while carrying the F.A.S.T.-key with you.
2. The hazard indicator flashes twice and outside chime sounds twice. The corre-

sponding door or the liftgate will unlock.

3. Push the request switch again within 2 seconds.
4. The hazard indicator flashes twice and outside chime sounds twice again. All the doors and the liftgate will unlock.

All doors will be locked automatically unless one of the following operations is performed within 30 seconds after pushing the request switch while the doors are locked.

- Opening any door.
- Pushing the ignition switch.

During this 30 seconds time period, if the UNLOCK  button on the F.A.S.T.-key is pushed, all doors will be locked automatically after another 30 seconds.

NOTE:

The unlocking operation can be changed in selective unlock in the Vehicle Settings of the multi-information display. For additional information, see “Vehicle Settings” (P.2-26).

Opening liftgate

1. Carry the F.A.S.T.-key.
2. Push the liftgate opener switch .
3. The liftgate will unlock and then open.

BATTERY SAVER SYSTEM

When all the following conditions are met for a period of time, the battery saver system will cut off the power supply to prevent battery discharge.

- The ignition switch is in the ON position. (See “Push-button ignition switch positions” (P.5-14).)
- All doors are closed, and
- The shift lever is in the P (Park) position.

WARNINGS AND AUDIBLE REMINDERS

To help prevent the vehicle from moving unexpectedly by erroneous operation of the F.A.S.T.-key listed on the following chart or to help prevent the vehicle from being stolen, chime or beep sounds inside and outside the vehicle and the warning display appears on the multi-information display.

When a chime or beep sounds or the warning display appears, be sure to check the vehicle and F.A.S.T.-key.

See “Troubleshooting guide” (P.3-13) and “Multi-information display” (P.2-21).

3-12 Pre-driving checks and adjustments

TROUBLESHOOTING GUIDE

Verify the location of all F.A.S.T.-keys that are programmed for the vehicle. If another F.A.S.T.-key is in range or inside the vehicle, the vehicle system may respond differently than expected.

	Symptom	Possible cause	Action to take
When stopping the engine	The Shift to Park warning appears on the display and the inside warning chime sounds continuously.	The shift lever is not in the P (Park) position.	Push the park button to shift to the P (Park) position.
When opening the driver's door to get out of the vehicle	The Door/liftgate open warning appears on the display.	The ignition switch is in the ON position.	Place the ignition switch in the OFF position.
When closing the door after getting out of the vehicle	The No Key Detected warning appears on the display, the outside chime sounds three times and the inside warning chime sounds three times.	The ignition switch is in the ON position and the engine is running.	Place the ignition switch in the OFF position.
	The red Shift to Park warning appears on the display and the inside side chime sounds continuously.	The ignition switch is in the ON position and the shift lever is not in the P (Park) position.	Push the park button to shift to the P (Park) position and place the ignition switch in the OFF position.
	The Rear Seat Alert is activated message appears on the display, the horn sounds three times twice, or a Check Rear Seat warning appears on the display.	The Rear Seat Alert is activated.	Check the back seat for all articles, clear the Rear Seat Alert warning message by using the steering switches.
When closing the door with the inside lock knob pushed to LOCK	The outside chime sounds for approximately three seconds and all the doors unlock.	The F.A.S.T.-key is inside the vehicle.	Carry the F.A.S.T.-key with you.
When pushing the door handle request switch (if so equipped) to lock the door	The outside chime sounds for approximately three seconds.	The F.A.S.T.-key is inside the vehicle.	Carry the F.A.S.T.-key with you.

When pushing the ignition switch to start the engine	The Key battery Low warning appears on the display.	The battery charge is low.	Replace the battery with a new one. (See “F.A.S.T.-key battery replacement” (P.8-20).)
	The No Key Detected warning appears on the display.	The F.A.S.T.-key is not in the vehicle.	Carry the F.A.S.T.-key with you.
When pushing the ignition switch	The Key System Error warning appears on the display.	It warns of a malfunction with the F.A.S.T.-key.	It is recommended that you contact an authorized Mitsubishi Motors dealer.

3-14 Pre-driving checks and adjustments

Condition:

[Edit: 2021/ 2/ 10 Model: DG-D]

HOW TO USE REMOTE KEYLESS ENTRY FUNCTION

WARNING

- Radio waves could adversely affect electric medical equipment. Those who use a pacemaker should contact the electric medical equipment manufacturer for the possible influences before use.
- The F.A.S.T.-key transmits radio waves when the buttons are pushed. The FAA advises that the radio waves may affect aircraft navigation and communication systems. Do not operate the F.A.S.T.-key while on an airplane. Make sure the buttons are not operated unintentionally when the unit is stored during a flight.

CAUTION

- Do not allow the F.A.S.T.-key, which contains electrical components, to come into contact with water or salt water. This could affect the system function.
- Do not drop the F.A.S.T.-key.
- Do not strike the F.A.S.T.-key sharply against another object.

- Do not change or modify the F.A.S.T.-key.
- Wetting may damage the F.A.S.T.-key. If the F.A.S.T.-key gets wet, immediately wipe until it is completely dry.
- If the outside temperature is below 14°F (-10°C) degrees, the battery of the F.A.S.T.-key may not function properly.
- Do not place the F.A.S.T.-key for an extended period in an area where temperatures exceed 140°F (60°C).
- Do not attach the F.A.S.T.-key with a key holder that contains a magnet.
- Do not place the F.A.S.T.-key near equipment that produces a magnetic field, such as a TV, audio equipment, personal computers or cellular phone.

NOTE:

On vehicles equipped with the door mirror folding switch, the door mirrors automatically retract or extend when all the doors and liftgate are locked or unlocked using the F.A.S.T.-key function.

This function can be deactivated. See an authorized Mitsubishi Motors dealer for details.

The remote keyless entry function can operate all door locks using the remote keyless entry function of the F.A.S.T.-key. The remote keyless entry function can operate at a distance of

approximately 40 ft (12 m) from the vehicle. (The operating distance depends upon the conditions around the vehicle.)

The remote keyless entry function will not operate:

- When the F.A.S.T.-key is not within the operational range.
- When the F.A.S.T.-key battery is discharged.

The remote keyless entry function can also operate the vehicle alarm.

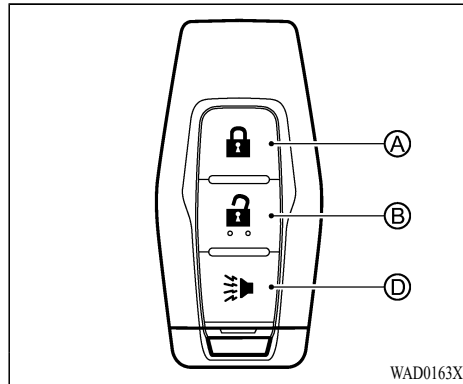

Type A

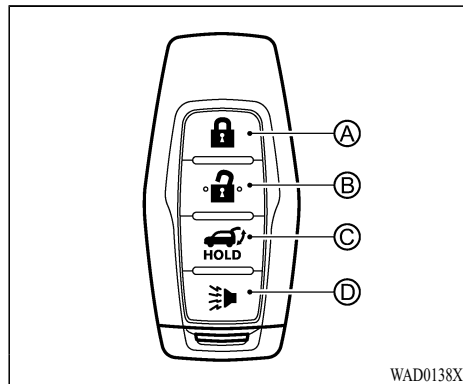

Type B

- Ⓐ LOCK button
- Ⓑ UNLOCK button
- Ⓒ Power liftgate button
- Ⓓ PANIC button

When you lock or unlock the doors or the liftgate, the hazard indicator will flash and the horn (or the outside chime) will sound as a confirmation. For details, see “Setting hazard indicator and horn mode” (P.3-18).

Locking doors

1. Place the ignition switch in the OFF position.
2. Carry the F.A.S.T.-key with you.*
3. Close all the doors.
4. Push the LOCK button Ⓐ on the F.A.S.T.-key.
5. All the doors and the liftgate will lock.
6. The hazard indicator flashes once and the horn chirps once.

*: Doors will not lock with the F.A.S.T.-key while the ignition switch is in the ON position.

Operate the door handles to confirm that the doors have been securely locked.

Unlocking doors

1. Push the UNLOCK button Ⓑ on the F.A.S.T.-key once.
2. The hazard indicator flashes twice. The driver’s door will unlock.
3. Push the UNLOCK button again within 2 seconds.
4. The hazard indicator flashes twice. All the doors and the liftgate will unlock.

All doors will be locked automatically unless one of the following operations is performed within 30 seconds after pushing the UNLOCK button while the doors are locked.

- Opening any door (including the liftgate).
- Pushing the ignition switch.

During this 30 seconds time period, if the UNLOCK button is pushed, all doors will be locked automatically after another 30 seconds.

NOTE:

The unlocking operation can be changed in selective unlock in the Vehicle Settings of the multi-information display. For additional information, see “Vehicle Settings” (P.2-26).

Opening/closing liftgate (if so equipped)

1. Push the power liftgate button  © for more than 1 second.
2. The liftgate will automatically open.

The outside chime sounds 3 times.

To close the liftgate, push the power liftgate button  for more than 1 second.

The liftgate will automatically close. The outside chime sounds 3 times.

If the button  is pushed while the liftgate is being opened or closed, the liftgate will reverse.

Using panic alarm

If you are near your vehicle and feel threatened, you may activate the alarm to call attention as follows:

1. Push the PANIC  button © on the F.A.S.T.-key for **more than 1 second**.
2. The theft warning alarm and headlights will stay on for 30 seconds.
3. The panic alarm stops when:
 - It has run for 30 seconds, or
 - Any of the buttons on the F.A.S.T.-key is pushed. (Note: the PANIC button must be pushed for more than 1 second.)

- The ignition switch is place in the ON position.

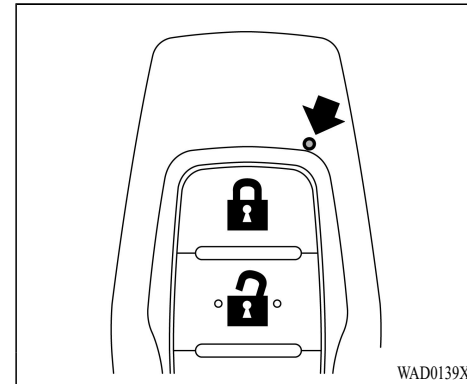





F.A.S.T.-key button operation light

The light blinks only when you push any button on the F.A.S.T.-key. The light illumination only signifies that the F.A.S.T.-key has transmitted a signal. You may look and/or listen to verify that the vehicle has performed the intended operation. If the light does not blink, your battery may be too weak to communicate to the vehicle. If this occurs, the battery may need to be replaced.



For additional information regarding the replacement of a battery, see “F.A.S.T.-key battery replacement” (P.8-20).

Setting hazard indicator and horn mode



This vehicle is set in hazard indicator and horn mode when you first receive the vehicle.

In hazard indicator and horn mode, when the LOCK  button  is pushed, the hazard indicator flashes once and the horn chirps once. When the UNLOCK  button  is pushed, the hazard indicator flashes twice.



If horns are not necessary, the system can be switched to the hazard indicator mode.

In hazard indicator mode, when the LOCK  button is pushed, the hazard indicator flashes once. When the UNLOCK  button is pushed, the hazard indicator flashes twice.

Hazard indicator and horn mode:



Operation	DOOR LOCK	DOOR UNLOCK
Pushing door handle request switch (if so equipped) or liftgate request switch (if so equipped)	HAZARD - once OUTSIDE CHIME - once	HAZARD - twice OUTSIDE CHIME - twice
Pushing  or  button	HAZARD - once HORN - once	HAZARD - twice OUTSIDE CHIME - none

Hazard indicator mode:

Operation	DOOR LOCK	DOOR UNLOCK
Pushing door handle request switch (if so equipped) or liftgate request switch (if so equipped)	HAZARD - once OUTSIDE CHIME - none	HAZARD - twice OUTSIDE CHIME - none
Pushing  or  button	HAZARD - once HORN - none	HAZARD - twice OUTSIDE CHIME - none

HOOD

Switching procedure:

To switch the hazard indicator and horn (chime) operation, push the LOCK  Ⓐ and UN-LOCK  Ⓑ buttons on the F.A.S.T.-key simultaneously for more than 4 seconds.

- When the hazard indicator mode is set, the hazard indicator flashes 3 times.
- When the hazard indicator and horn mode is set, the hazard indicator flashes once and the horn chirps once.

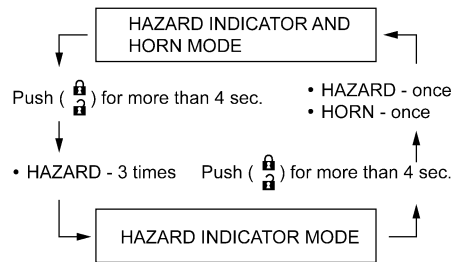

The horn operation can also be turned on or off in the multi-information display. See "Vehicle Settings" (P.2-26).

 **WARNING**

- **Make sure the hood is completely closed and latched before driving. Failure to do so could cause the hood to fly open and result in an accident.**
- **Never open the hood if steam or smoke is coming from the engine compartment to avoid injury.**

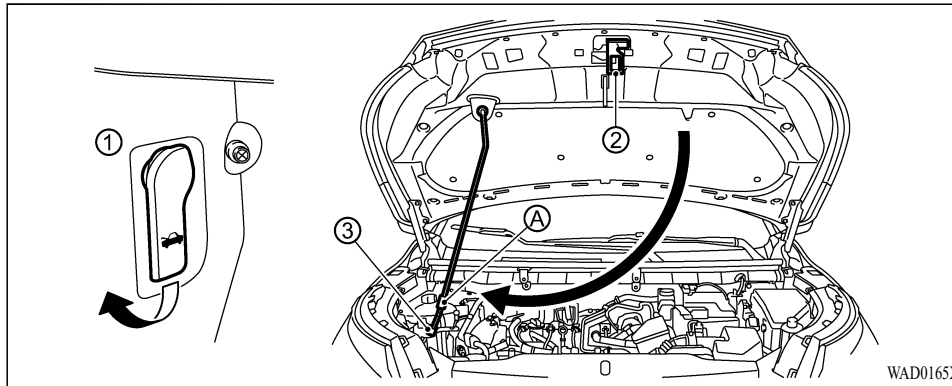

1. Pull the hood lock release handle ① located below the driver's side instrument panel; the hood springs up slightly.
2. Push the lever ② underneath the front of the hood upwards as illustrated with your fingertips.
3. Raise the hood.
4. Remove the support rod and insert it into the slot ③.

Hold the coated part ④ when removing or resetting the support rod. Avoid direct contact with the metal parts, as they may be hot immediately after the engine has been stopped.

When closing the hood:

1. While supporting the hood, return the support rod to its original position.
2. Slowly lower the hood to about 8 to 12 in (20 to 30 cm) approximately the hood lock, then let it drop.
3. Make sure it is securely latched.

LIFTGATE

WARNING

- Always be sure the liftgate has been closed securely to prevent it from opening while driving.
- Do not drive with the liftgate open. This could allow dangerous exhaust gases to be drawn into the vehicle. For additional information, refer to "Exhaust gas (carbon monoxide)" (P.5-5).
- To help avoid risk of injury or death through unintended operation of the vehicle and or its systems, including entrapment in windows or inadvertent door lock activation, do not leave children, people who require the assistance of others or pets unattended in your vehicle. Additionally, the temperature inside a closed vehicle on a warm day can quickly become high enough to cause a significant risk of injury or death to people and pets.
- Always be sure that hands and feet are clear of the door frame to avoid injury while closing the liftgate.
- When there is a build up of snow or ice, it should be removed before opening the liftgate. If you open the liftgate without removing it, there is a possibility that the liftgate may close suddenly due to the weight of that snow or ice.

- When you open the liftgate make sure that the liftgate is opened fully and remains fully open. If you only open the liftgate halfway, there is a risk that the liftgate may drop and slam shut. If you open the liftgate while your vehicle is parked on an incline, it is more difficult to do so than on the flat and also it may suddenly open or drop and slam shut. When using the height memory of the power liftgate, the liftgate will open only to the set position.
- When opening and closing the liftgate, make sure of the surrounding safety and keep enough space for back and upper of the vehicle and be careful not to hit your head or pinch your hands, neck, etc.

CAUTION

Do not use accessory carriers that attach to the liftgate. Doing so will cause damage to the vehicle.

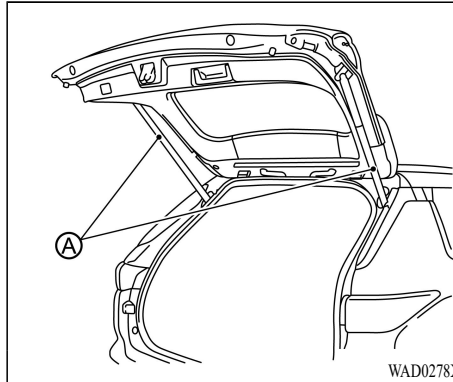

NOTE:

Gus struts  are installed to support the liftgate.

To prevent damage or faulty operation:

- Do not hold the gas struts when closing the liftgate.
- Also do not push or pull the gas struts.
- Do not attach any plastic material, tape, etc., to the gas struts.
- Do not tie string, etc., around the gas struts.
- Do not hang any object on the gas struts.

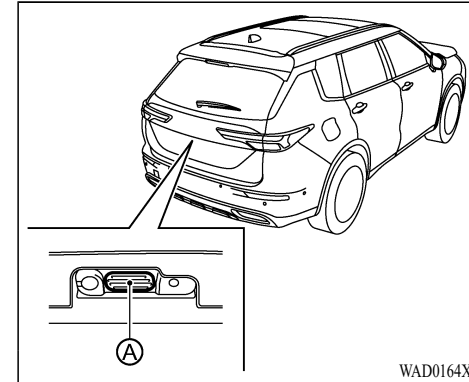

OPERATING MANUAL LIFT-GATE

To open the liftgate, unlock it and push the opener switch . Pull up the liftgate to open.

The liftgate can be unlocked by:

- pushing the “UNLOCK”  button on the key.
- pushing the liftgate request switch (if so equipped).
- pushing the door handle request switch (if so equipped) or opener switch when you carry the F.A.S.T.-key with you.
- pushing the power door lock switch to the unlock position.

Pre-driving checks and adjustments 3-21

NOTE:

The liftgate cannot be pulled up when you do not open it as soon as the liftgate opener switch is pushed. In this case, push the liftgate opener switch again and pull up the liftgate.

To close the liftgate, pull down until it securely closed.

OPERATING POWER LIFT-GATE (if so equipped)

WARNING

Make sure the power liftgate is completely open before loading and unloading luggage.

CAUTION

Do not apply excessive force on the power liftgate when opening or closing it. Doing so could cause a breakdown.

NOTE:

- The power liftgate does not operate normally under the following conditions:
 - When parked on a steep incline

— In strong winds

— When the power liftgate is covered with snow

- If the battery of fuse is replaced while the power liftgate is open, it cannot be closed automatically. In this case, close the power liftgate manually.

To operate the power liftgate, the vehicle must be in the “P” (Park) position.

The power liftgate will not operate if the battery voltage is low.

How to turn on/off the power liftgate

The power liftgate operation can be turned on or off in the multi-information display.

When the power liftgate is turned off, power operation is not available. When pushing the power liftgate button on the F.A.S.T.-key, only the liftgate latch is released.

NOTE:

- For models with power liftgate (with hands-free access): When washing, waxing or maintaining your vehicle, placing or replacing the body cover, or splashing water to the area around the kick motion sensor, turn off the power liftgate.
- If the power open or close operation is performed consecutively, the safety mode activates and the operation cannot be

performed for a certain period of time. In this case, wait for a while and then perform the operation.

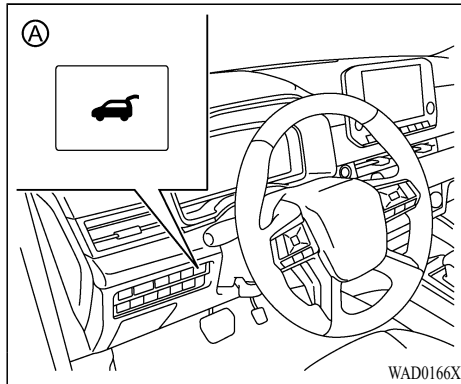

Power liftgate switch — Instrument panel

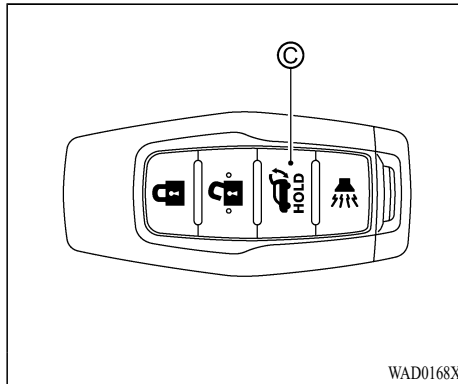

Power liftgate button - Key

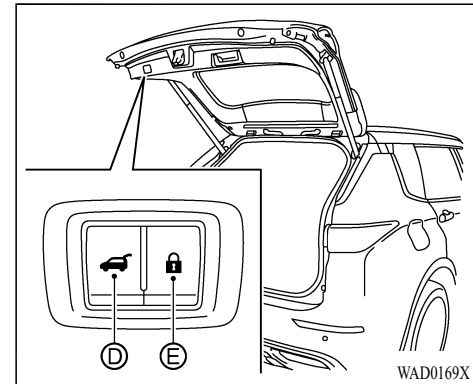

Power liftgate close switch and close and lock switch — Liftgate

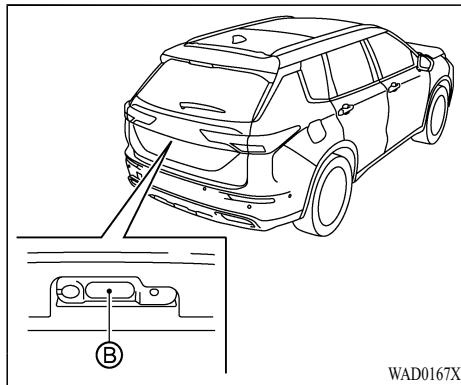

Liftgate opener switch

Power open (using switches)

When the liftgate is fully closed, the liftgate will fully open automatically by:

- pushing the power liftgate switch **A** on the instrument panel for more than 1 second
- pushing the liftgate opener switch **B**
- pushing the power liftgate button **C** on the key for more than 1 second

The outside chime sounds 3 times.

NOTE:

The liftgate can be opened by the power liftgate switch **A**, liftgate opener switch **B** or the power liftgate button **C** even if the

liftgate is locked. The liftgate can be unlocked and opened independently of the other doors, even when they are locked.

Power close

When the liftgate is fully opened, the liftgate will fully close automatically by:

- pushing the power liftgate switch Ⓐ on the instrument panel
- pushing the power liftgate button Ⓒ on the key for more than 1 second
- pushing the power liftgate close switch Ⓓ on the lower part of the liftgate

The outside chime sounds 3 times when the liftgate starts closing.

Power close and lock

When the liftgate is opened, the liftgate will fully close and lock automatically by pushing the power liftgate close and lock switch Ⓔ on the lower part of the liftgate.

The hazard flashes 2 times and the outside chime sounds when the liftgate starts closing.

Stop and reverse function

The power liftgate will stop immediately if one of the following actions is performed during power open or close.

- pushing the power liftgate switch Ⓐ

- pushing the liftgate opener switch Ⓖ
- pushing the power liftgate close switch Ⓓ on the lower part of the liftgate
- pushing the power liftgate button Ⓒ on the key
- the kick motion sensor detects a kicking motion (if so equipped) (See “Operating the power liftgate using the hands-free access” (P.3-25).)

And then the power liftgate will move in the reverse direction if one of the above actions is performed again.

The outside chime sounds when the liftgate starts to reverse.

Auto reverse function

The auto-reverse function enables the liftgate to automatically reverse when something is caught in the liftgate as it is opening or closing. When the control unit detects an obstacle, the liftgate will reverse and return to the full open or full close position.

If a second obstacle is detected, the liftgate motion will stop. The liftgate will enter the manual mode.

A pinch sensor is mounted on each side of the liftgate. If an obstacle is detected by the pinch sensor during power close, the liftgate will reverse and return to the full open position immediately.

NOTE:

If the pinch sensor is damaged or removed, the power close function will not operate.

WARNING

There is a small distance immediately before the closed position that cannot be detected. Make sure that all passengers keep their hands, etc., clear from the liftgate opening before closing the liftgate.

CAUTION

- The safety mechanism will sometimes not operate depending on the condition of the trapped object or how it is trapped. Therefore, be especially careful not to trap a hand, part of your body or an object at this time.
- If the safety mechanism is repeatedly activated, the liftgate could be switched to manual operation. Once the power liftgate is fully opened or closed, normal automatic operation is possible again.

Manual mode

If power operation is not available, the liftgate can be operated manually. Power operation may not be available if multiple obstacles have been detected in a single power cycle or if the battery voltage is low. When the power liftgate is turned off, the liftgate can be opened manually by pushing the liftgate opener switch. If the power liftgate opener switch is pushed during power open or close, the power operation will be canceled and the liftgate can be operated manually.

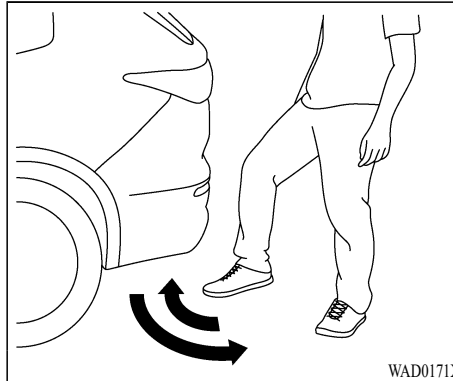
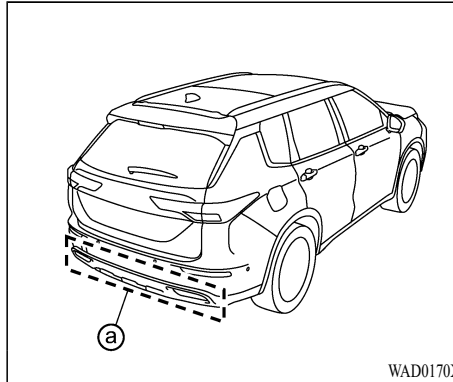

OPERATING THE POWER LIFTGATE USING THE HANDS-FREE ACCESS (if so equipped)

The kick motion sensor (a), located on the back of the rear bumper, enables you to open or close the liftgate in hands-free.

When you move your foot under and away from the operating range similarly to a kicking motion, the liftgate will open or close automatically.

NOTE:

- **The kick motion sensor may not function under the following conditions:**
 - When operating near a location where strong radio waves are transmitted, such as a TV tower, power station, electric vehicle charging station or broadcasting station.
 - When the vehicle is parked near a parking meter.
 - When wearing a material that hardly conduct electricity, such as rubber boots.
 - When water adheres to the rear bumper by washing, rain, etc.
- **The power liftgate may not operate when your foot remains in the operating range.**

Pre-driving checks and adjustments 3-25

- The kick motion sensor function may not detect a kicking motion underneath a tow-bar (if so equipped), however the normal functionality is retained either side of the tow-bar (if so equipped).
- When washing, waxing or maintaining your vehicle, placing or replacing the body cover, or splashing water to the area around the kick motion sensor, turn off the power liftgate.
- When lots of water splashes the rear bumper by such as heavy rain, etc. Or do not carry the F.A.S.T. -key within the operating range during this time.

CAUTION

- If the hands-free access remains on, you may be injured due to a sudden operating of the power liftgate resulting from a possible reaction of the kick motion sensor. Refer to “How to turn on/off the power liftgate” (P.3-22).
- When the F.A.S.T.-key is carried with you near the liftgate, even someone, who does not carry the F.A.S.T.-key, may be able to open or close the liftgate with a kick motion.
- Prevent your foot from touching the rear bumper during a kicking motion. Otherwise, the rear bumper and the kick motion

sensor may be damaged.

- Do not perform a kick motion near the exhaust system components while they are hot. You may severely burn yourself.
- Do not perform a kick motion on an unstable place (for example, on a slope or a muddy ground, etc.).

Power open or close function

The liftgate will fully open automatically using the kick motion sensor.

1. Carry the F.A.S.T.-key.
2. Move your foot under and away from the rear bumper similarly to a kicking motion within the operation range of the kick motion sensor.
3. The liftgate will automatically open or close.

Stop and reverse function

The power liftgate will stop immediately if a kick motion is performed during power open or close.

And then the power liftgate will move in the reverse direction if a kick motion is performed again. The power liftgate can be reversed when you carry the F.A.S.T.-key.

LIFTGATE CLOSE AND LOCK FUNCTION

If the liftgate is pulled down to a partly open position, the liftgate will pull itself to the closed position.

Do not apply excessive force when the auto closure is operating. Excessive force applied may cause the mechanism to malfunction.

WARNING

Be careful not to trap your hands or fingers during operation of the liftgate close and lock function. If you think this could occur, push a power liftgate operation switch or use the hands-free access. The power liftgate will return to the door ajar position.

CAUTION

- The liftgate will automatically close from a partly open position. To avoid pinching, keep hands and fingers away from liftgate opening.
- Do not let children operate the liftgate.

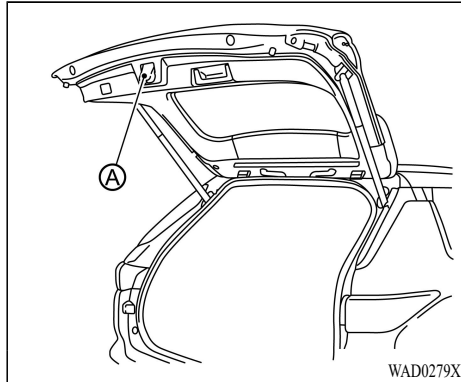

CAUTION

- Do not touch the latch **A** on the inside of the power liftgate. Otherwise, your fingers could be trapped in the latch when the liftgate close and lock function operates.
- The liftgate close and lock function operates even when the automatic operation of the power liftgate is set to OFF. Therefore, be especially careful not to trap a hand or finger at this time.

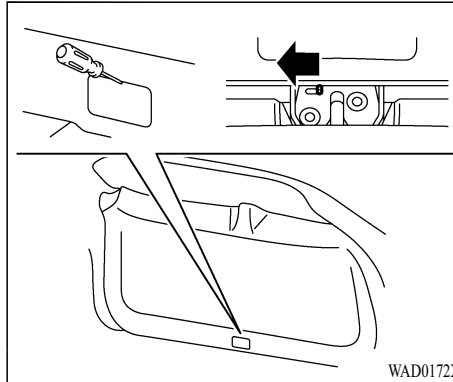

LIFTGATE RELEASE LEVER

WARNING

Always keep the release lever lid on the liftgate closed when driving so that your luggage cannot accidentally bump the lever and open the liftgate.

If the liftgate cannot be opened with **A**, **B** or **C** switch (see “Power open (using switches)” (P.3-23)), due to a discharged battery, follow these steps.

1. Fold the third row seats down. See “Third row seats” (P.1-9).

2. Using a suitable tool to open the lid, then insert the tool in the access opening. Move the release lever to the left. The liftgate will be unlatched.
3. Push the liftgate up to open.

Contact an authorized Mitsubishi Motors dealer as soon as possible for repair.

HEIGHT MEMORY FUNCTION

The liftgate can be set to open to a specific height by performing the following:

1. Open the liftgate.
2. Pull the liftgate down to the desired position and hold the liftgate (the liftgate will have some resistance when being manually adjusted).
3. While holding the liftgate in position, press and hold the power liftgate close switch **D** located on the liftgate for approximately 3 seconds or until 2 beeps are heard.

The liftgate will open to the selected position setting. To change the position of the liftgate, repeat steps 1-3 for setting the position of the liftgate.

FUEL FILLER DOOR

CAUTION

Do not set the height of the liftgate below approximately 55 in (1,400 mm) to the floor using garage mode. Even if you set the height below approximately 55 in (1,400 mm) to the floor, the height will automatically be set to approximately 55 in (1,400 mm) to the floor.

WARNING

- Fuel is extremely flammable and highly explosive under certain conditions. You could be burned or seriously injured if it is misused or mishandled. Always stop the engine and do not smoke or allow open flames or sparks near the vehicle when refueling.

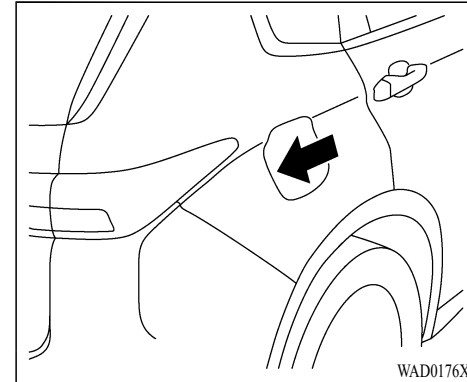

OPENING THE FUEL FILLER DOOR

The fuel filler door is linked to the vehicle's electric door locking mechanism. To open the fuel filler door, push the rear end of the fuel filler door when the door lock is released.

NOTE:

If you open the fuel filler door, refuel as soon as possible.

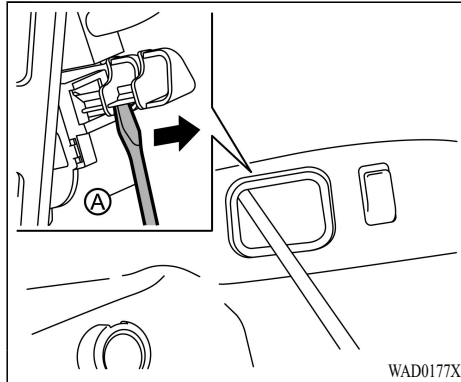

Emergency opening of the fuel filler door

If you have to open the fuel filler door when the vehicle battery is discharged, perform the following procedure:

1. Remove the cover on the right wall of the cargo area.
2. Operate the rod in the arrow direction by a suitable tool **A** to unlock the fuel filler door.

The rod is located behind the seat belt.

Slide the seat belt backwards to approach the rod.

Use a flashlight if necessary.

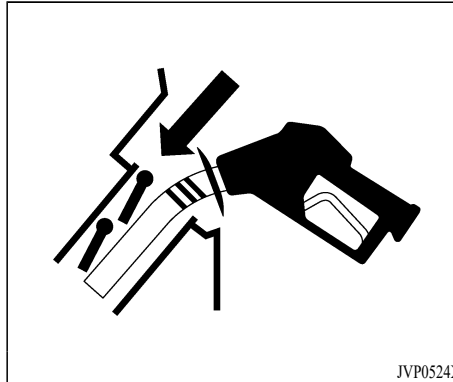

Instructional label

HOW TO REFUEL

This vehicle has the capless fuel filler that does not have a fuel filler cap.

As illustrated, be sure to insert the fueling nozzle slowly, in a straight way into the fuel filler opening as far as it will go before fueling.

Never move the nozzle during refueling.

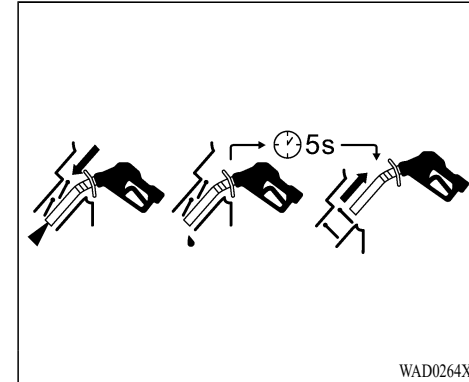

Instructional label

When the fuel tank is filled, the refueling is stopped automatically. Pull off the nozzle approximately 5 seconds after the refueling is automatically stopped.

Close the fuel filler door after refueling.

CAUTION

- Do not attempt to open the flaps on the fuel filler opening using any tool other than the fueling nozzle.
- Be sure to close the fuel filler door before using an automatic car wash or a high pressure car wash.

- If fuel is spilled on the vehicle body, flush it away with water to avoid paint damage.

WARNING

- Gasoline is extremely flammable and highly explosive under certain conditions. You could be burned or seriously injured if it is misused or mishandled. Always stop engine and do not smoke or allow open flames or sparks near the vehicle when refueling.
- Before opening the fuel filler door, be sure to get rid of your body's static electricity by touching a metal part of the vehicle or fuel pump. Any static electricity on your body could create a spark that ignites fuel vapor.
- Perform the whole refueling process (opening the fuel tank filler door, removing the fuel cap, etc.) by yourself; do not let any other person near the fuel tank filler. If you allowed a person to help you and that person was carrying static electricity, fuel vapor could be ignited.
- Do not move away from the fuel tank filler until refueling is finished. If you moved away and did something else (for example, sitting on a seat) part-way through the refueling process, you could pick up a fresh charge of static electricity.

- Be careful not to inhale fuel vapor. Fuel contains toxic substances.
- Keep the doors and windows closed while refueling the vehicle. If they were open, fuel vapor could get into the cabin.
- Do not attempt to top off/overfill the fuel tank after the fuel pump nozzle shuts off automatically. Continued refueling may cause fuel overflow, resulting in fuel spray and possibly a fire.
- Never pour fuel into the throttle body to attempt to start your vehicle.
- Do not fill a portable fuel container in the vehicle or trailer. Static electricity can cause an explosion of flammable liquid, vapor or gas in any vehicle or trailer. To reduce the risk of serious injury or death when filling portable fuel containers:
 - Always place the container on the ground when filling.
 - Do not use electronic devices when filling.
 - Keep the pump nozzle in contact with the container while you are filling it.
 - Use only approved portable fuel containers for flammable liquid.

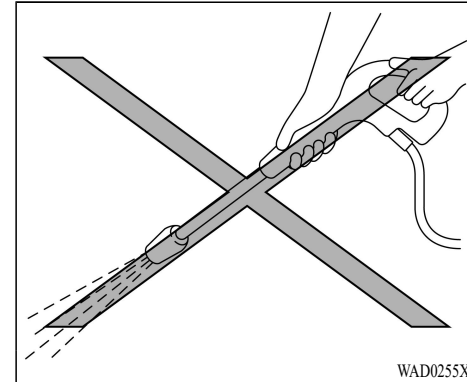

CAUTION

- If fuel is spilled on the vehicle body, flush it away with water to avoid paint damage.
- Do not apply direct water pressure, such as high-pressure sprayer, on the capless fuel filler opening when the fuel filler door is opened.

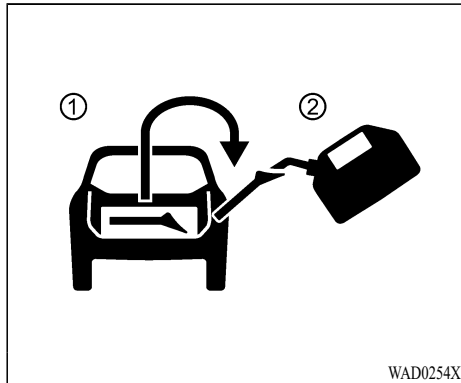
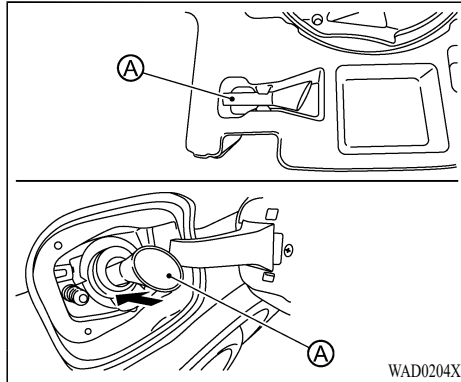

When refueling from a portable fuel container

When refueling from a portable fuel container, use the fuel filler funnel (A). The fuel filler funnel is stored under the cargo area floor.

Take out the fuel filler funnel from the cargo area floor ①, push it in to open the inner fuel lids and refuel ②.

After refueling, remove the funnel from the fuel filler opening. Wipe the funnel clean and return it to the storage.

TILT/TELESCOPIC STEERING

WARNING

Do not adjust the steering wheel while driving. You could lose control of your vehicle and cause an accident.

SUNVISORS

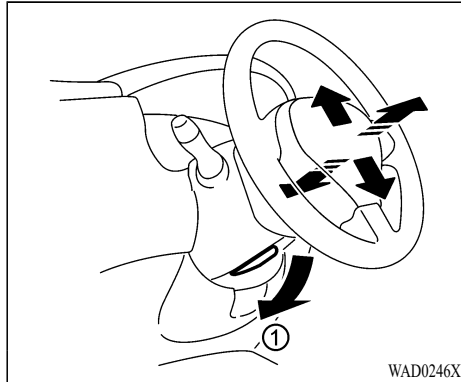

WAD0246X

TILT OR TELESCOPIC OPERATION

Pull the lock lever ① down and adjust the steering wheel up, down, forward or rearward to the desired position. Push the lock lever up securely to lock the steering wheel in place.

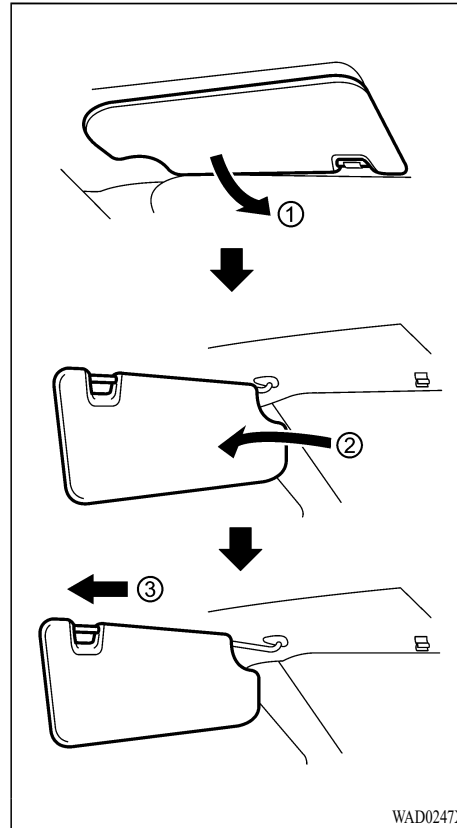

WAD0247X

1. To block glare from the front, swing down the sunvisor ①.
2. To block glare from the side, remove the sunvisor from the center mount and swing it to the side ②.
3. Slide the sunvisor ③ in or out as needed.

CAUTION

- Do not store the sunvisor before returning the extension to its original position.
- Do not pull the extension sunvisor forcedly downward.

PULL-UP TYPE SUNSHADE (rear door) (if so equipped)

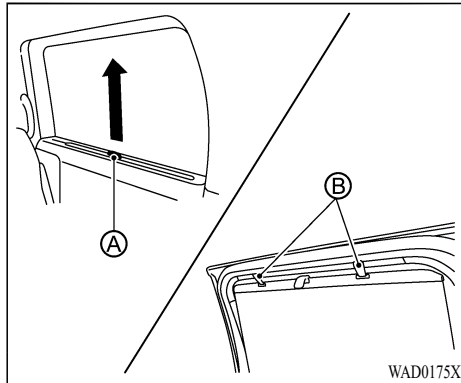

CAUTION

- Do not pull the sunshade in any direction other than upward. Doing so may damage the sunshade.
- Do not release the knob **A** when pulling up or storing the sunshade. If doing so, the sunshade rolls down rapidly and your finger may be pinched between the sunshade and the window opening.
- Do not drive the vehicle with the windows open when using the sunshade. Otherwise, an injury could occur if a gust of wind hits the shade when it is unhooked, or the shading parts may get wrinkled.

The pull-up type sunshades are equipped on the rear seat windows.

To raise the sunshade, pull the knob **A** up and push the knob into the hook **B**.

To store the sunshade, remove the sunshade from the hooks and lower it.

MIRRORS

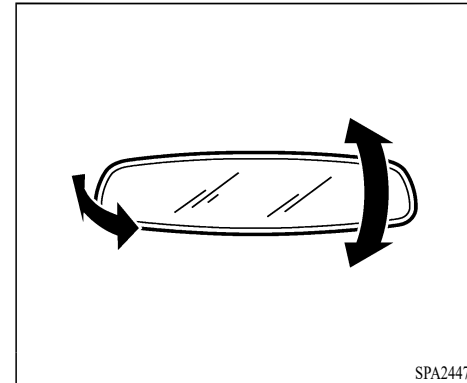

INSIDE MIRROR

Adjust the angle of the inside mirror to the desired position.

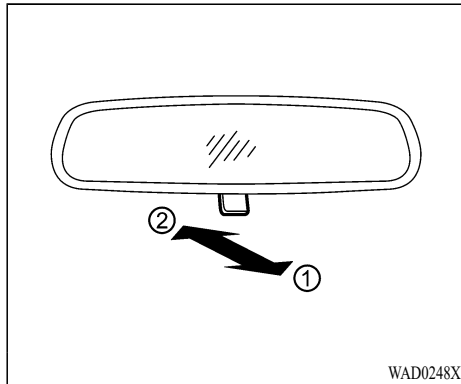

Manual anti-glare type (if so equipped)

The night position ① will reduce glare from the headlights of vehicles behind you at night.

Use the day position ② when driving in daylight hours.

WARNING

Use the night position only when necessary, because it reduces rear view clarity.

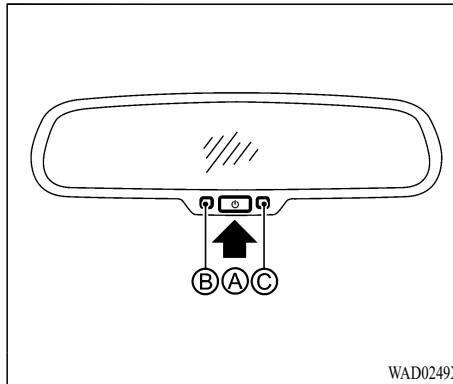

Automatic anti-glare type (if so equipped)

The inside mirror is designed so that it automatically changes reflection according to the intensity of the headlights of the following vehicle.

The anti-glare system will be automatically turned on when the ignition switch is placed in the ON position.

When the anti-glare system is turned on, the indicator light ③ will illuminate and excessive glare from the headlights of the vehicle behind you will be reduced.

Push the ④ switch ⑤ to make the inside

rearview mirror operate normally. The indicator light will turn off. Push the ④ switch again to turn the system on.

Do not hang any objects on the mirror or apply glass cleaner. Doing so will reduce the sensitivity of the sensor ③, resulting in improper operation.

DOOR MIRRORS

WARNING

Objects viewed in the door mirror on the passenger side are closer than they appear. Be careful when moving to the right. Using only this mirror could cause an accident. Use the inside mirror or glance over your shoulder to properly judge distances to other objects.

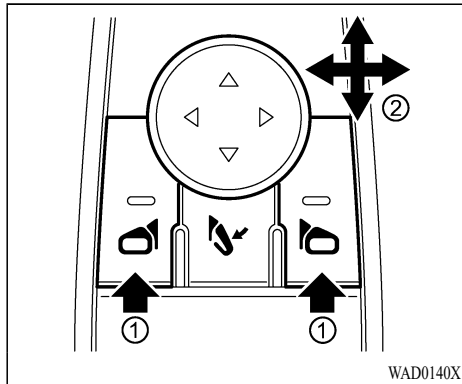

Adjusting door mirrors

The door mirror control switch is located on the driver's armrest.

The door mirror will operate only when the ignition switch is in the ACC or ON position.

Push the right or left door mirror switch to select the right or left side mirror ①, then adjust ② using the control switch.

Heated door mirrors (if so equipped)

The door mirrors will be heated when the electric rear window defroster switch is operated. (See "Electric rear window and door mirror defroster switch" (P.2-52).)

Foldable door mirrors

CAUTION

- Do not drive with the mirrors stored. You will be unable to see behind the vehicle.
- If the mirrors were folded or unfolded by hand, there is a chance that the mirror will move forward or backward during driving. If the mirrors were folded or unfolded by hand, be sure to adjust them again electrically before driving.

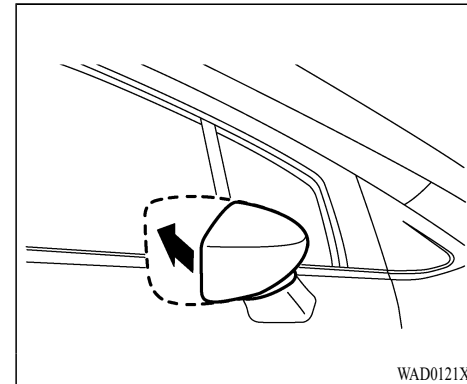

Example

Manual type:

Fold the door mirror by pushing it toward the rear of the vehicle.

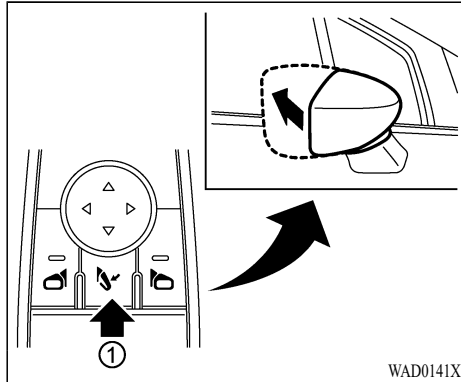

Remote control type:

The door mirror remote control operates when the ignition switch is in the ACC or ON position.

To fold the door mirrors, push the door mirror folding switch ①. To unfold, push the switch again.

The mirrors automatically retract or extend when the doors are locked or unlocked using the key buttons or the F.A.S.T.-key operation. This function can be deactivated. See an authorized Mitsubishi Motors dealer for details.

If mirrors are manually operated or bumped, the mirror body can become loose at the pivot point. To correct electronic mirror operation,

cycle the mirrors by pushing the door mirror folding switch until the mirrors are in the open position.

NOTE:

- Be careful not to get your hands trapped while a mirror is moving.
- If you move a mirror by hand or it moves after hitting a person or object, you may not be able to return it to its original position using the door mirror folding switch. If this happens, push the door mirror folding switch to place the mirror in its folded position and then push the switch again to return the mirror to its original position.
- When freezing has occurred and mirrors fail to operate as intended, please refrain from repeated pushing of the door mirror folding switch as this action can result in burn-out of the mirror motor circuits.

Folding and unfolding the mirrors without using the door mirror folding switch (automatic extension function)

Functions can be modified as stated below. Please consult an authorized Mitsubishi Motors dealer.

- The outside mirrors automatically fold when the ignition switch is placed in the OFF position, and unfold when the ignition switch is placed in the ON position.
- The auto fold feature for the outside mirrors is disabled.

Reverse auto tilt function (if so equipped)

When backing up the vehicle, the right or left door mirrors will turn downward automatically to provide better rear visibility.

1. Place the ignition switch in the ON position.
2. Move the shift lever to the R (Reverse) position.
3. Choose the right or left door mirror by operating the door mirror control switch.
4. The door mirror surface moves downward.

The door mirror surface can be adjusted and stored when the reverse auto tilt function is activated. (See "Adjusting door mirrors" (P.3-35).)

When one of the following conditions has occurred, the door mirror surfaces will return to their original positions.

- Push the right or left door mirror control switch again.

- The shift lever is moved to any position other than R (Reverse) and the vehicle speed exceeds 5 MPH (8 km/h).
- After 9 seconds have passed since the shift lever is moved to any position other than R (Reverse).
- The ignition switch is placed in the OFF position.

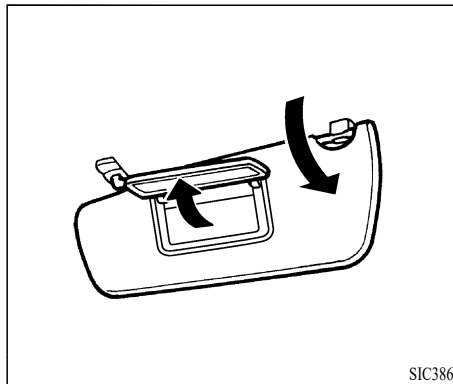

VANITY MIRROR

To use the front vanity mirror, pull down the sunvisor and pull up the cover.

DRIVER MEMORY SETTINGS (if so equipped)

The driver memory settings has two features:

- Memory storage function
- Entry/exit function

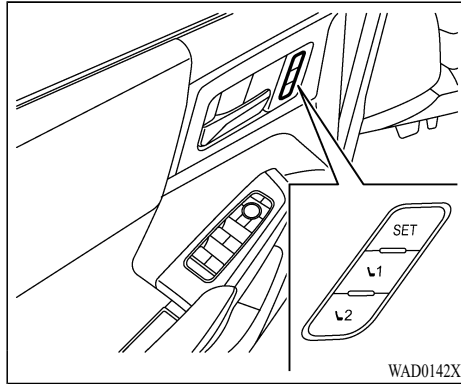

MEMORY STORAGE FUNCTION

Two positions for the driver's seat and door mirrors can be stored in the personal memory. Follow these procedures to use the memory system.

1. Adjust the driver's seat and door mirrors to the desired positions by manually operating each adjusting switch. For additional information, refer to "Seats" (P.1-2) and "Door mirrors" (P.3-34).
2. Push the SET switch and, within 5 seconds, push the memory switch (1 or 2).

3. The indicator light for the pushed memory switch will come on and stay on for approximately 5 seconds.
4. The chime will sound if the memory has been stored.

NOTE:

If a new memory position is stored in the same memory switch, the previous memory position will be overwritten by the new stored position.

Confirming memory storage

Push the SET switch. If a memory position has not been stored in the switch (1 or 2) the indicator light for the respective switch will come ON for approximately 0.5 seconds. If a memory position has been stored in the switch (1 or 2) then the indicator light for the respective switch will stay ON for approximately 5 seconds.

Recalling switch memory positions

To recall the manually stored positions, push the memory switch (1 or 2). The driver's seat and the door mirrors will move to the positions stored in the memory switch.

Linking log-in function to a stored memory position (models with navigation system)

The log-in function can be linked to a stored memory position with the following procedure.

1. Place the ignition switch in the ON position while carrying the F.A.S.T.-key that was registered to the vehicle with a log-in function.

NOTE:



Make sure the F.A.S.T.-key is far apart. Otherwise, the vehicle may detect the wrong F.A.S.T.-key.

2. Adjust the position of the driver's seat and door mirrors. (See "Seats" (P.1-2) and "Door mirrors" (P.3-34).)
3. Place the ignition switch in the OFF position.

The next time you log in (selecting the user on the display) after placing the ignition switch in the ON position while carrying the F.A.S.T.-key, the system will automatically adjust to the memorized driving position. (See the separate Smartphone-link Display Audio (SDA) Owner's Manual.)

Linking an F.A.S.T.-key to a stored memory position (models without navigation system)

Each F.A.S.T.-key can be linked to a stored memory position (memory switch 1 or 2) with the following procedure.

1. Follow steps 1-3 in the “Memory storage function” (P.3-38) for storing the memory position.
2. The indicator light for the pushed memory switch will come on. While the indicator light is on for 5 seconds, press the  button and the  button on the F.A.S.T.-key in succession. The indicator light of the linked memory switch will blink. After the indicator light goes off, the F.A.S.T.-key is linked to that memory setting.

Once it is linked, when ignition switch is placed in the OFF position, pressing the  button on the F.A.S.T.-key will move the driver’s seat and door mirrors to the linked memory switch position.

NOTE:

If a new memory position is stored in the linked memory switch, then the F.A.S.T.-key will link the new position and overwrites the previous position.

ENTRY/EXIT FUNCTION

This system is designed so that the driver’s seat will automatically move when the shift lever is in the P (Park) position. This allows the driver to get into and out of the driver’s seat more easily.

The driver’s seat will slide backward:

- When the driver’s door is opened with the ignition switch placed in the OFF position.
- When the ignition switch is changed from ON to OFF with the driver’s door open.

The driver’s seat will return to the previous position:

- When the ignition switch is placed in the ON position while the shift position is in the P (Park) position.

The entry/exit function can be canceled through “Vehicle Settings” in the multi-information display by performing the following:

- Switch the “Exit Seat Slide” from ON to OFF. For additional information, refer to “Vehicle Settings” (P.2-26).

SYSTEM OPERATION

The driver memory settings will not work or will stop operating under the following conditions:

- When the vehicle is moving. (The driver’s seat returning function can be operated if the vehicle speed is below 2 MPH (3 km/h).)
- When any of the memory switches are pushed while the driver memory settings is operating.
- When the switch for the driver’s seat is pushed while the driver memory settings is operating.
- When the seat has already been moved to the memorized position.
- When no seat position is stored in the memory switch.
- When the shift lever is moved from P (Park) to any other position.

MEMO

3-40 Pre-driving checks and adjustments

Condition:

4 Monitor, heater, air conditioner, audio and phone systems

Smartphone-link Display Audio (SDA)		How to turn on and off predictive course lines	4-20
Owner's Manual	4-2	Multi Around Monitor system limitations	4-20
Rearview camera (if so equipped)	4-2	System maintenance	4-22
Rearview camera system operation	4-3	Moving Object Detection (MOD) (if so equipped)	4-23
How to read the displayed lines	4-4	MOD system operation	4-23
Difference between predictive and		Turning MOD on and off	4-25
actual distances	4-4	MOD system limitations	4-25
How to park with predictive course lines	4-6	System maintenance	4-26
Adjusting the screen	4-7	Ventilators	4-26
How to turn ON and OFF predictive course lines	4-8	Center ventilators	4-26
Rearview camera system limitations	4-8	Side ventilators	4-27
System maintenance	4-9	Rear ventilators	4-27
Multi Around Monitor (if so equipped)	4-9	Heater and air conditioner	4-28
Types of views of the Multi Around Monitor	4-11	Dual-zone automatic climate control	4-29
Multi Around Monitor system operation	4-13	3-zone automatic climate control	4-31
Difference between predictive and		Operating tips	4-33
actual distances	4-16	Servicing air conditioner	4-33
How to park with predictive course lines	4-18	Antenna	4-34
How to switch the display	4-19	Shark fin antenna	4-34
Adjusting the screen	4-20	Car phone or CB radio	4-34



SMARTPHONE-LINK DISPLAY AUDIO (SDA) OWNER'S MANUAL

Refer to Smartphone-link Display Audio (SDA) Owner's Manual that includes the following information.

Available functions may vary depending on the models and specifications.

- Audio
- Hands-Free Phone
- Apple CarPlay®
- Android Auto™
- MITSUBISHI CONNECT powered by SiriusXM®
- Navigation system
- Voice recognition
- Information and settings viewable on navigation system

REARVIEW CAMERA (if so equipped)

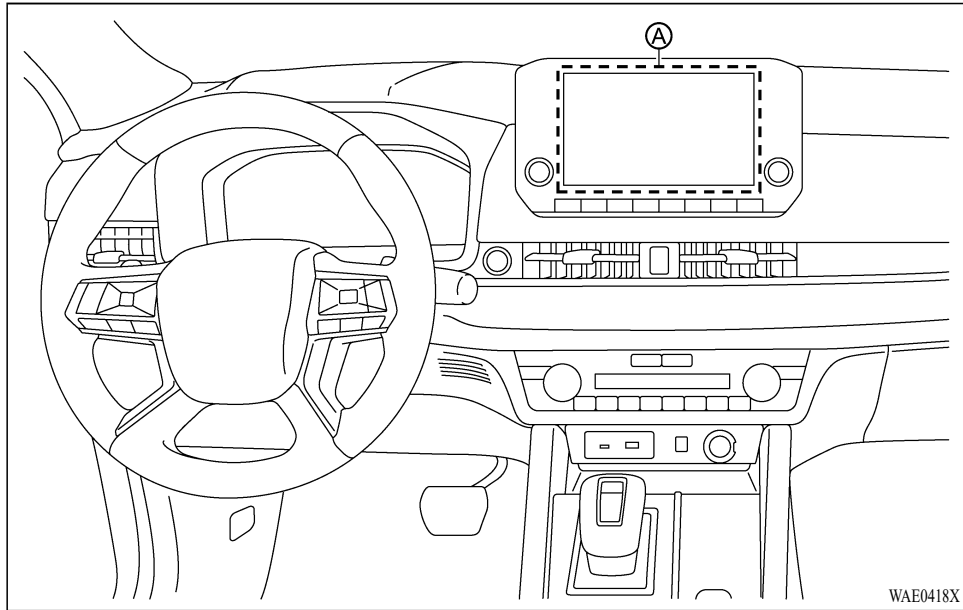

WAE0418X

Ⓐ Smartphone-link Display Audio (SDA)

WARNING

- Failure to follow the warnings and instructions for proper use of the Rearview camera could result in serious injury or

death.

- Rearview camera is a convenience feature and is not a substitute for proper backing. Always turn and look out the windows, and check mirrors to be sure that it is safe to move before operating the vehicle. Always back up slowly.

4-2 Monitor, heater, air conditioner, audio and phone systems

- The system is designed as an aid to the driver in showing large stationary objects directly behind the vehicle, to help avoid damaging the vehicle.
- The distance guide line and the vehicle width line should be used as a reference only when the vehicle is on a level paved surface. The distance viewed on the monitor is for reference only and may be different than the actual distance between the vehicle and displayed objects.

CAUTION

- If the camera lens gets dirty, a clear image cannot be obtained. As necessary, rinse the lens with clean water and gently wipe with a clean, soft cloth.
- To avoid damaging the camera;
 - Do not rub the cover excessively or polish it by using an abrasive compound.
 - Do not disassemble the camera.
 - Do not splash hot water directly on the lens.
 - Do not spray the camera and its surroundings with high-pressure water.

— Make sure that the liftgate is securely closed when backing up.

The Rearview camera system automatically shows a rear view of the vehicle when the shift lever is placed in the R (Reverse) position.

The radio can still be heard while the Rearview camera is active.

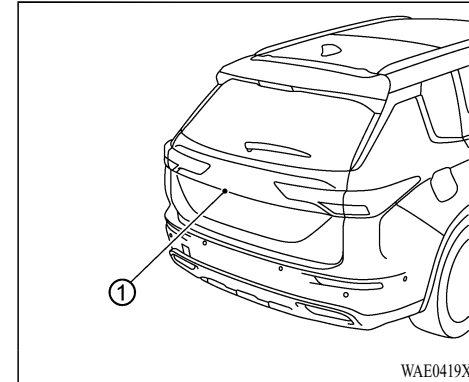

To display the rear view, the Rearview camera system uses a camera located just above the vehicle's license plate ①.

REARVIEW CAMERA SYSTEM OPERATION

When the ignition switch is placed in the ON position, move the shift lever to the R (Reverse) position to operate the Rearview camera.

The rearview image will be displayed on the Smartphone-link Display Audio (SDA) screen.

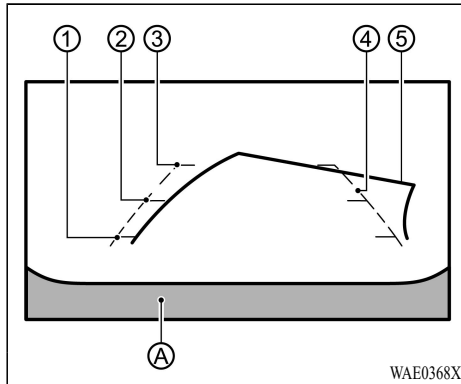

HOW TO READ THE DISPLAYED LINES

Guiding lines which indicate the vehicle width and distances to objects with reference to the bumper line **A** are displayed on the monitor.

Distance guide lines:

Indicate distances from the vehicle body.

- Red line ①: approximately 1.5 ft (0.5 m)
- Yellow line ②: approximately 3 ft (1 m)
- Green line ③: approximately 7 ft (2 m)

Vehicle width guide lines ④:

Indicate the vehicle width when backing up.

Predictive course lines ⑤:

Indicate the predictive course when backing up. The predictive course lines will be displayed on the monitor when the shift lever is in the R (Reverse) position and if the steering wheel is turned. The predictive course lines will move depending on how much the steering wheel is turned and will not be displayed while the steering wheel is in the straight ahead position.

The vehicle width guide lines and the width of the predictive course lines are wider than the actual width and course.

DIFFERENCE BETWEEN PREDICTIVE AND ACTUAL DISTANCES

The displayed guidelines and their locations on the ground are for approximate reference only. Objects on uphill or downhill surfaces or projecting objects will be actually located at distances different from those displayed in the monitor relative to the guidelines (refer to illustrations). When in doubt, turn around and view the objects as you are backing up, or park and exit the vehicle to view the positioning of objects behind the vehicle.

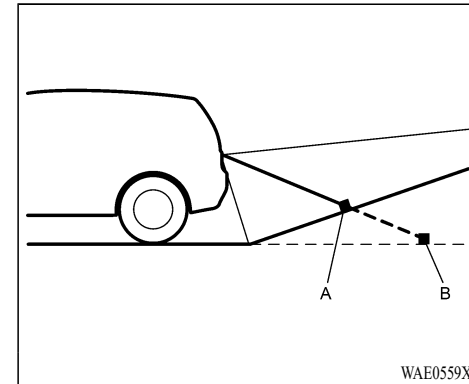

A: Actual objects

B: Objects shown on the screen

Backing up on a steep uphill

When there is an upward slope behind the vehicle, objects shown on the screen will appear to be farther off than they actually are.

4-4 Monitor, heater, air conditioner, audio and phone systems

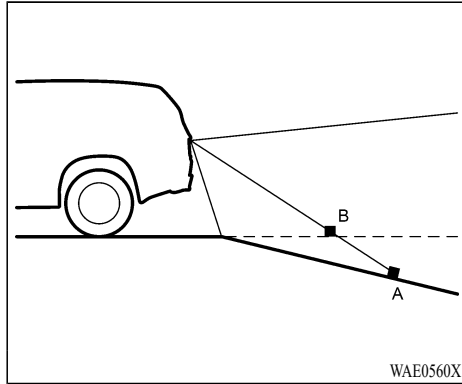

A: Actual objects
 B: Objects shown on the screen

Backing up on a steep downhill

When there is a downward slope behind the vehicle, objects shown on the screen will appear to be closer than they actually are.

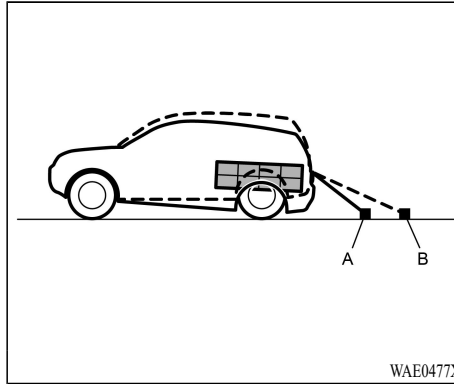

A: Actual objects
 B: Objects shown on the screen

Weighed down by weigh

When the rear of the vehicle is weighed down with the weight of passengers and luggage in the vehicle, objects shown on the screen will appear to be farther off than they actually are.

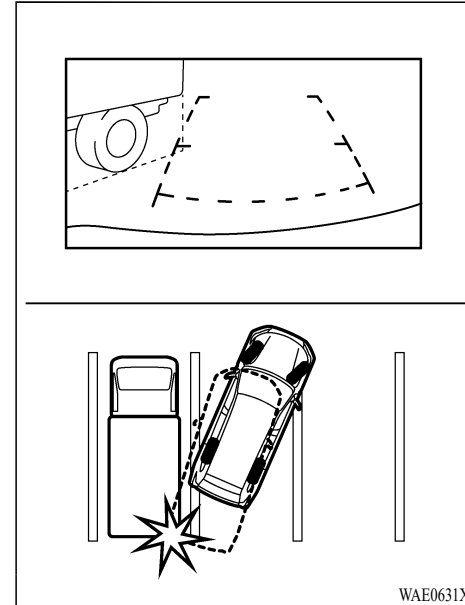

Backing up near a projecting object

When the vehicle is approaching a truck, the reference lines indicate that your vehicle will clear the truck. In reality, the truck is in your path.

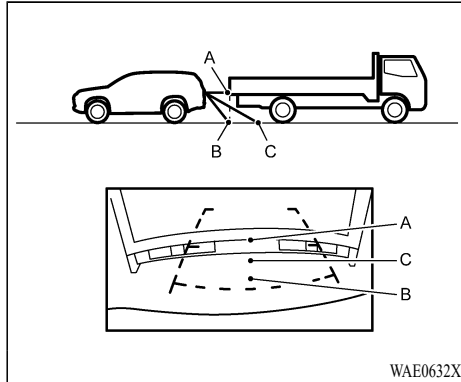

Backing up behind a projecting object

When there is an object behind the vehicle that has upper sections projecting in the direction of the vehicle, the reference lines on the screen will indicate that point A is the farthest point and point B is the closest point to the vehicle. In reality, point A and B are actually the same distance from the vehicle, and point C is farther off than point A and B.

HOW TO PARK WITH PREDICTIVE COURSE LINES

⚠ WARNING

- If the tires are replaced with different sized tires, the predictive course lines may be displayed incorrectly.
- On a snow-covered or slippery road, there may be a difference between the predictive course line and the actual course line.
- If the battery is disconnected or becomes discharged, the predictive course lines may be displayed incorrectly. If this occurs, please perform the following procedures:
 - Turn the steering wheel from lock to lock while the engine is running.
 - Drive the vehicle on a straight road for more than 5 minutes.
- When the steering wheel is turned with the ignition switch in the ON position, the predictive course lines may be displayed incorrectly.

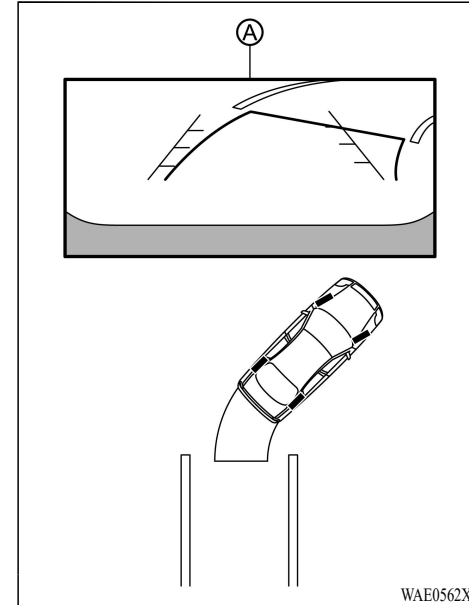

1. Visually check that the parking space is safe before parking your vehicle.
2. The rear view of the vehicle is displayed on the screen ① when the shift lever is moved to the R (Reverse) position.

4-6 Monitor, heater, air conditioner, audio and phone systems

Condition:

[Edit: 2021/ 2/ 10 Model: DG-D]

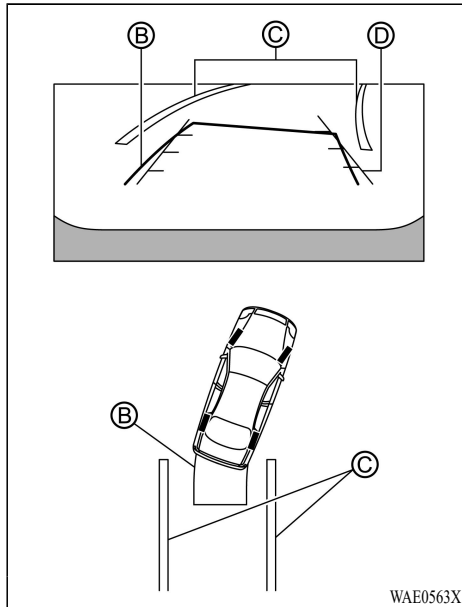

3. Slowly back up the vehicle adjusting the steering wheel so that the predictive course lines ② enter the parking space ③ .
4. Maneuver the steering wheel to make the vehicle width guide lines ④ parallel to the parking space ③ while referring to the predictive course lines.

5. When the vehicle is parked in the space completely, move the shift lever to the P (Park) position and apply the parking brake.

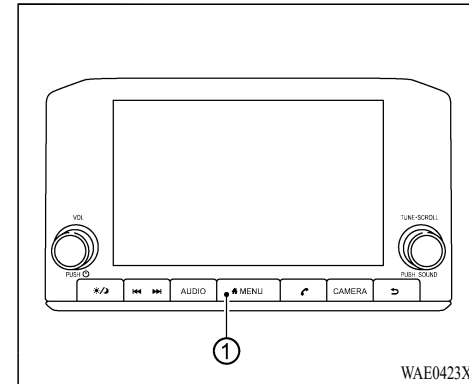

ADJUSTING THE SCREEN

1. Push the MENU button ①.
2. Touch the “Settings” key and then touch the “Camera” key.
3. Touch the “Display Settings” key.
4. Touch the “Brightness”, “Contrast”, “Tint”, “Color”, or “Black Level” key.
5. Adjust the item by touching the “+” or “-” key on the touch screen display.

NOTE:

Do not adjust any of the display settings of the Rearview camera while the vehicle is moving. Make sure the parking brake is firmly applied.

Monitor, heater, air conditioner, audio and phone systems 4-7

HOW TO TURN ON AND OFF PREDICTIVE COURSE LINES

To turn the predictive course lines on and off when the shift lever is in the P (Park) position, perform the following operation.

1. Push the MENU button
2. Touch the “Settings” key and then touch the “Camera” key.
3. Touch the “Predictive Course Lines” key to turn the feature ON or OFF.

Pushing the CAMERA button while the shift lever is in the R (Reverse) position can also turn on and off the predictive course lines.

REARVIEW CAMERA SYSTEM LIMITATIONS

WARNING

Listed below are the system limitations for Rearview camera. Failure to operate the vehicle in accordance with these system limitations could result in serious injury or death.

- The system cannot completely eliminate blind spots and may not show every object.
- Underneath the bumper and the corner areas of the bumper cannot be viewed on the Rearview camera because of its monitoring range limitation. The system will

not show small objects below the bumper, and may not show objects close to the bumper or on the ground.

- Objects viewed in the Rearview camera differ from actual distance because a wide-angle lens is used.
- Objects in the Rearview camera will appear visually opposite compared to when viewed in the rearview and door mirrors.
- Use the displayed lines as a reference. The lines are highly affected by the number of occupants, fuel level, vehicle position, road conditions and road grade.
- Make sure that the liftgate is securely closed when backing up.
- Do not put anything on the rearview camera. The rearview camera is installed above the license plate.
- When washing the vehicle with high-pressure water, be sure not to spray it around the camera. Otherwise, water may enter the camera unit causing water condensation on the lens, a malfunction, fire or an electric shock.
- Do not strike the camera. It is a precision instrument. Otherwise, it may malfunction or cause damage resulting in a fire or an electric shock.

The following are operating limitations and do

not represent a system malfunction:

- When the temperature is extremely high or low, the screen may not clearly display objects.
- When strong light directly shines on the camera, objects may not be displayed clearly.
- Vertical lines may be seen in objects on the screen. This is due to strong reflected light from the bumper.
- The screen may flicker under fluorescent light.
- The colors of objects on the Rearview camera may differ somewhat from the actual color of objects.
- Objects on the monitor may not be clear in a dark environment.
- There may be a delay when switching between views.
- If dirt, rain or snow accumulates on the camera, the Rearview camera may not display objects clearly. Clean the camera.
- Do not use wax on the camera lens. Wipe off any wax with a clean cloth dampened with a diluted mild cleaning agent, then wipe with a dry cloth.

MULTI AROUND MONITOR (if so equipped)

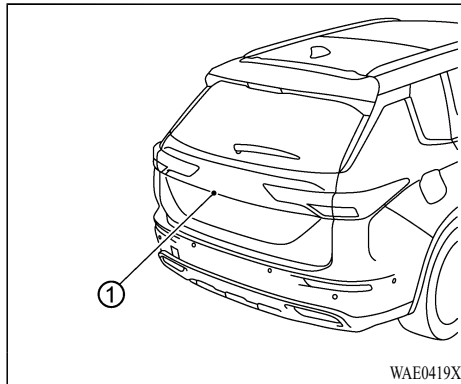

SYSTEM MAINTENANCE

CAUTION

- Do not use alcohol, benzine or thinner to clean the camera. This will cause discoloration.
- Do not damage the camera as the monitor screen may be adversely affected.

If dirt, rain or snow accumulates on the camera ①, Rearview camera may not display objects clearly. Clean the camera by wiping it with a cloth dampened with a diluted mild cleaning agent and then wiping it with a dry cloth.

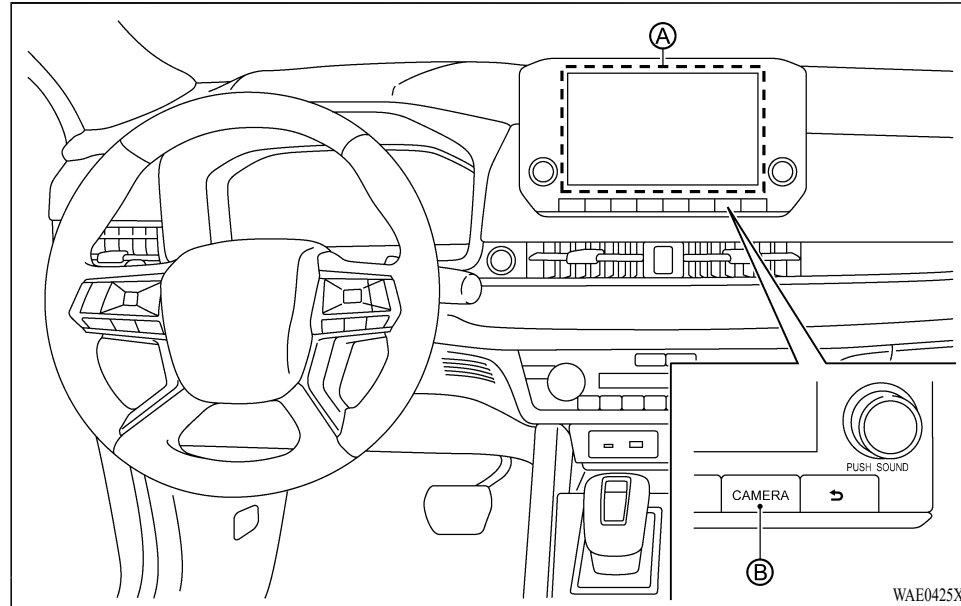

Ⓐ Smartphone-link Display Audio (SDA)

Ⓑ CAMERA button

WARNING

- Failure to follow the warnings and instructions for the proper use of the Multi Around Monitor system could result in serious injury or death.

Monitor, heater, air conditioner, audio and phone systems 4-9

- The Multi Around Monitor is a convenience feature and is not a substitute for proper vehicle operation because it has areas where objects cannot be viewed. The four corners of the vehicle in particular, are areas where objects do not always appear in the bird's-eye, front, or rear views. Always check your surroundings to be sure that it is safe to move before operating the vehicle. Always operate the vehicle slowly.
- The driver is always responsible for safety during parking and other maneuvers.

CAUTION

- If the camera lens gets dirty, a clear image cannot be obtained. As necessary, rinse the lens with clean water and gently wipe with a clean, soft cloth.
- To avoid damaging the camera;
 - Do not rub the cover excessively or polish it by using an abrasive compound.
 - Do not disassemble the camera.
 - Do not splash hot water directly on the lens.

- Do not spray the camera and its surroundings with high-pressure water.
- Make sure that the liftgate is securely closed when backing up.

The Multi Around Monitor system is designed as an aid to the driver in situations such as slot parking or parallel parking.

The monitor displays various views of the position of the vehicle in a split screen format. Not all views are available at all times.

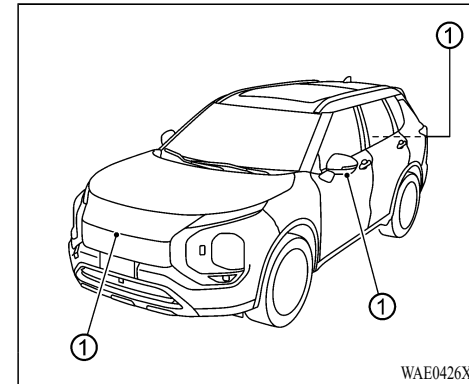

To display the multiple views, the Multi Around Monitor system uses cameras ① located in the front grille, on the vehicle's door mirrors and one just above the vehicle's license plate.

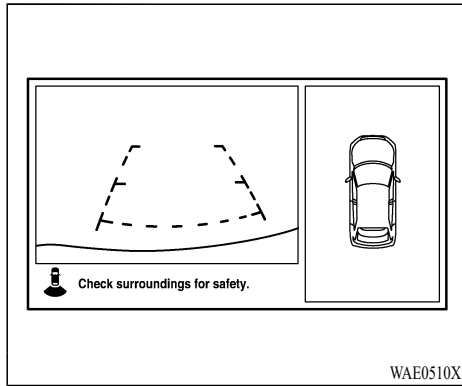

TYPES OF VIEWS OF THE MULTI AROUND MONITOR

Bird's eye-view/Rear-view mode

Views of the surroundings of the vehicle and behind the vehicle are displayed.

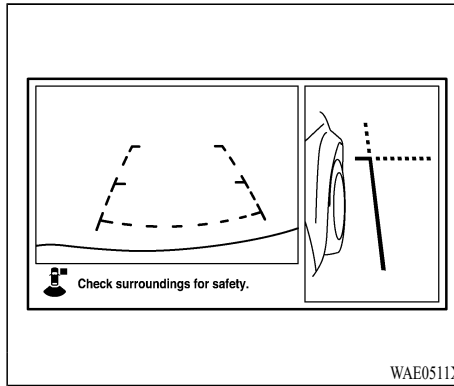

Side-view/Rear-view mode

Views of the passenger's side of the vehicle and behind the vehicle are displayed.

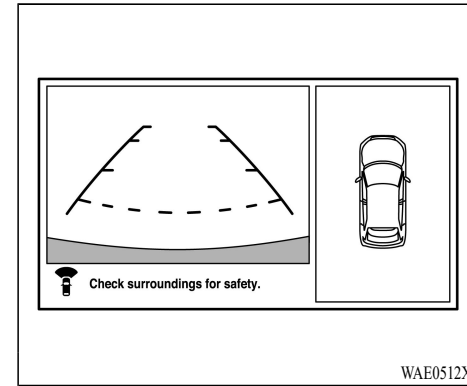

Bird's eye-view/Front-view mode

Views of the surroundings of the vehicle and the front of the vehicle are displayed.

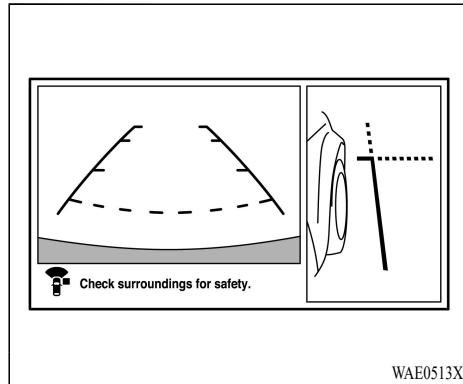

Side-view/Front-view mode

Views of the passenger's side of the vehicle and the front of the vehicle are displayed.

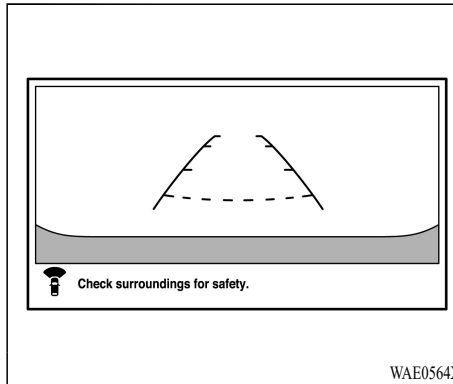

Front-wide view

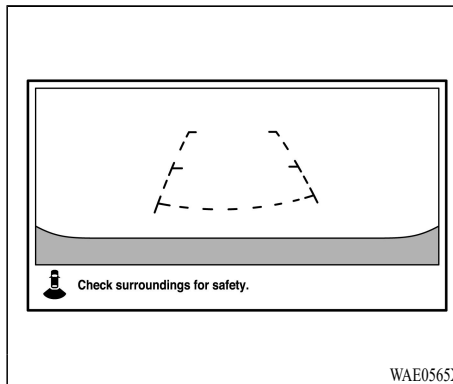

Rear-wide view

Front-wide/rear-wide view

Views of the front or rear of the vehicle are displayed.

CAUTION

The camera uses a special lens. As a result, images and distances shown on the screen are not exact.

NOTE:

- Because the cameras have a special lens, the lines on the ground between parking spaces may not look parallel on the screen.
- Under certain circumstances, it may become difficult to see an image on the screen, even when the system is functioning correctly.
 - In a dark area, such as at night.
 - When water drops or condensation are on the lens.
 - When sun light or headlights shine directly into the lens.
 - When a fluorescent light shines directly into the lens.
- If the atmospheric temperature is extremely hot or extremely cold, the camera images may not be clear. There is no

abnormality.

- If a wireless device is installed near the camera, the camera images may cause electrical system interference and the system may stop functioning properly.

MULTI AROUND MONITOR SYSTEM OPERATION

When the ignition switch is placed in the ON position, push the CAMERA button on the instrument panel or move the shift lever to the R (Reverse) position to operate the Multi Around Monitor.

The Multi Around Monitor images will be displayed on the Smartphone-link Display Audio (SDA) screen.

The screen displayed on the Multi Around Monitor will automatically return to the previous screen 3 minutes after the CAMERA button has been pushed with the shift lever in a position other than the R (Reverse) position.

Available views

WARNING

- The distance guide lines and the vehicle width guide lines should be used as a reference only when the vehicle is on a paved, level surface. The apparent distance

viewed on the monitor may be different than the actual distance between the vehicle and displayed objects.

- Use the displayed lines and the bird's-eye view as a reference. The lines and the bird's-eye view are greatly affected by the number of occupants, fuel level, vehicle position, road condition and road grade.
- If the tires are replaced with different sized tires, the predictive course lines and the bird's-eye view may be displayed incorrectly.
- When driving the vehicle up a hill, objects viewed in the monitor are farther than they appear. When driving the vehicle down a hill, objects viewed in the monitor are closer than they appear.
- Objects in the rear view will appear visually opposite compared to when viewed in the rearview and door mirrors.
- Use the mirrors or actually look to properly judge distances to other objects.
- On a snow-covered or slippery road, there may be a difference between the predictive course line and the actual course line.
- The vehicle width and predictive course lines are wider than the actual width and course.
- The displayed lines on the rear view will appear slightly off to the right because the rearview camera is not installed in the rear

center of the vehicle.

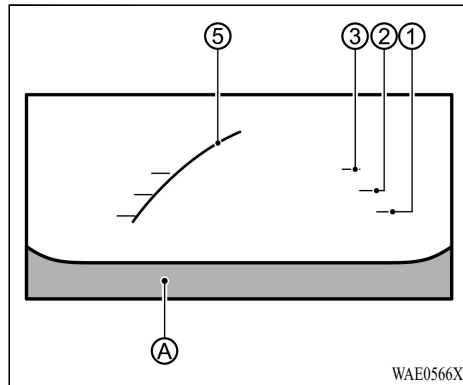

Front view

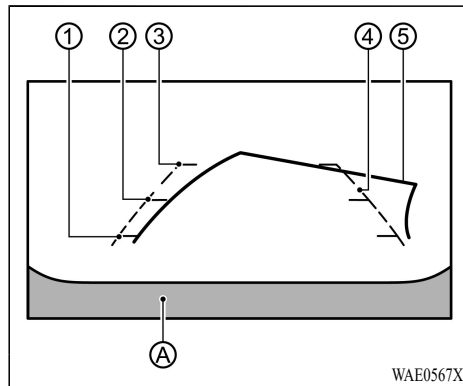

Rear view

Front and rear view:

Guiding lines that indicate the approximate vehicle width and distances to objects with reference to the vehicle body line ④, are displayed on the monitor.

Distance guide lines:

Indicate distances from the vehicle body.

- Red line ① : approximately 1.5 ft (0.5 m)
- Yellow line ② : approximately 3 ft (1 m)
- Green line ③ : approximately 7 ft (2 m)

Vehicle width guide lines ④ :

Indicate the vehicle width.

Predictive course lines ⑤ :

Indicate the predictive course when operating the vehicle. When the monitor displays the rear view, the predictive course lines will be displayed on the monitor if the steering wheel is turned. The predictive course lines will move depending on how much the steering wheel is turned and will not be displayed while the steering wheel is in the straight ahead position.

The front view will not be displayed when the vehicle speed is above 6 MPH (10 km/h).

NOTE:

- **When the monitor displays the front view and the steering wheel turns approximately 90 degrees or less from the straight ahead position, both the right**

and left predictive course lines ⑤ are displayed. When the steering wheel turns approximately 90 degrees or more, the predictive course line is displayed only on the opposite side of the turn.

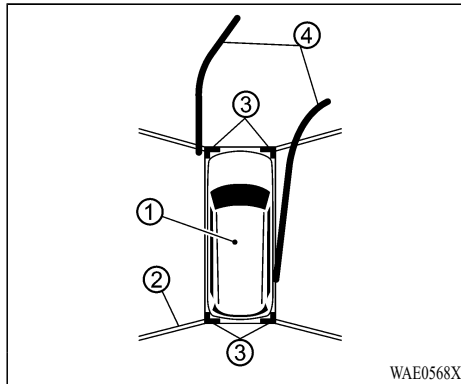

Bird's-eye view:

The bird's-eye view shows the overhead view of the vehicle which helps confirm the vehicle position and the predictive course to a parking space.

The vehicle icon ① shows the position of the vehicle. Note that the distance between objects viewed in the bird's-eye view differs from the actual distance.

The areas that the cameras cannot cover ② are indicated in black, if a parking sensor is not equipped.

After the ignition switch is placed in the ON position, the non-viewable area ② is highlighted in yellow for a few seconds after the bird's-eye

view is displayed.

The red markers ③ (if so equipped) are displayed when the parking sensor is turned off or the parking sensor is not available at the corner. Predictive course lines ④ indicate the predicted course when operating the vehicle.

WARNING

- Objects in the bird's-eye view will appear farther than the actual distance.
- Tall objects, such as a curb or vehicle, may be misaligned or not displayed at the seam of the views.
- Objects that are above the camera cannot be displayed.
- The view for the bird's-eye view may be misaligned when the camera position alters.
- A line on the ground may be misaligned and is not seen as being straight at the seam of the views. The misalignment will increase as the line proceeds away from the vehicle.

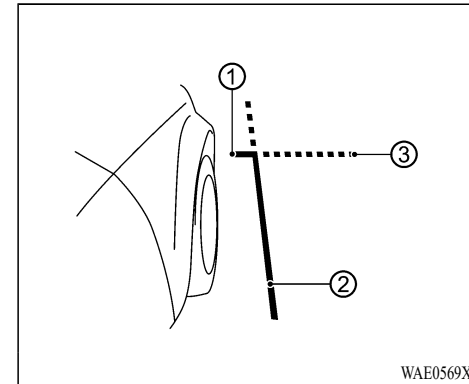

Front-side view:

Guiding lines:

Guiding lines that indicate the approximate width and the front end of the vehicle are displayed on the monitor.

The front-of-vehicle line ① shows the front part of the vehicle.

The side-of-vehicle line ② shows the vehicle width including the door mirrors.

The extensions ③ of both the front ① and side ② lines are shown with a green dotted line.

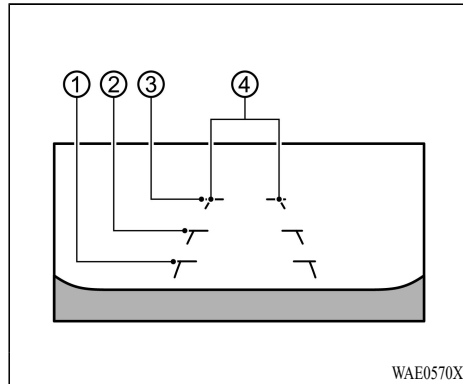

Front-wide view

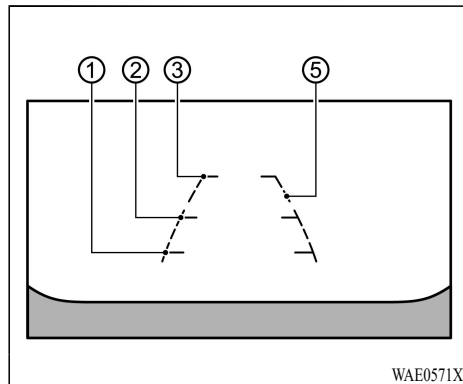

Rear-wide view

Front-wide/rear-wide view:

The front-wide view/rear-wide view shows a wider area on the entire screen and allows checking of the blind corners on the right and left sides. The front-wide view/rear-wide view displays an approximately 180-degree area while the front view and the rear view display an approximately 150-degree area. The predictive course lines are not displayed on the front-wide view /rear-wide view.

Distance guide lines ① - ③ :

Indicate distances from the vehicle body.

- Red line ① : approx. 1.5 ft (0.5 m)
- Yellow line ② : approx. 3 ft (1 m)
- Green line ③ : approx. 7 ft (2 m)

Vehicle width guide lines ④⑤ :

Indicate the approximate vehicle width.

DIFFERENCE BETWEEN PREDICTIVE AND ACTUAL DISTANCES

The displayed guidelines and their locations on the ground are for approximate reference only. Objects on uphill or downhill surfaces or projecting objects will be actually located at distances different from those displayed in the monitor relative to the guidelines (refer to illustrations). When in doubt, turn around and view the objects as you are backing up, or park and exit the vehicle to view the positioning of objects behind the vehicle.

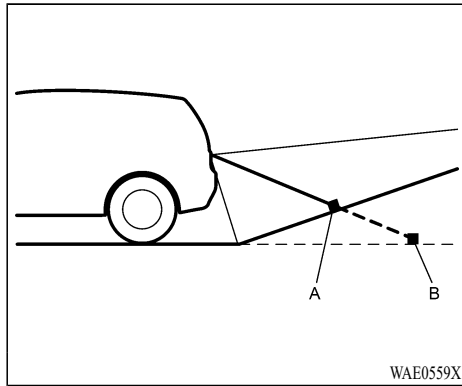

A: Actual objects
 B: Objects shown on the screen

Backing up on a steep uphill

When there is an upward slope behind the vehicle, objects shown on the screen will appear to be farther off than they actually are.

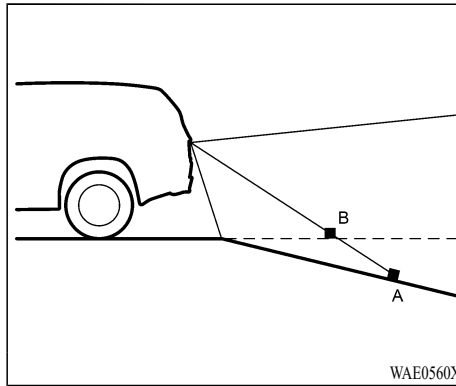

A: Actual objects
 B: Objects shown on the screen

Backing up on a steep downhill

When there is a downward slope behind the vehicle, objects shown on the screen will appear to be closer than they actually are.

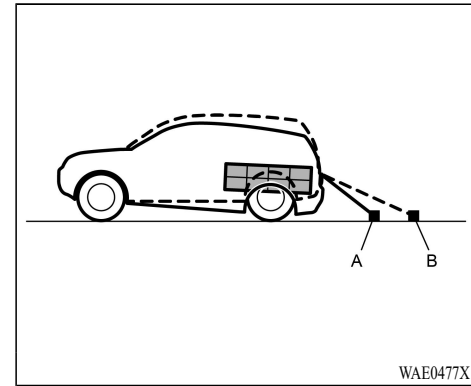

A: Actual objects
 B: Objects shown on the screen

Weighed down by weigh

When the rear of the vehicle is weighed down with the weight of passengers and luggage in the vehicle, objects shown on the screen will appear to be farther off than they actually are.

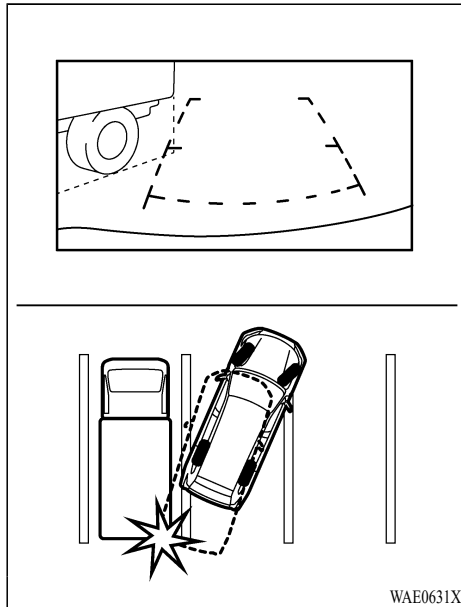

Backing up near a projecting object

When the vehicle is approaching a truck, the reference lines indicate that your vehicle will clear the truck. In reality, the truck is in your path.

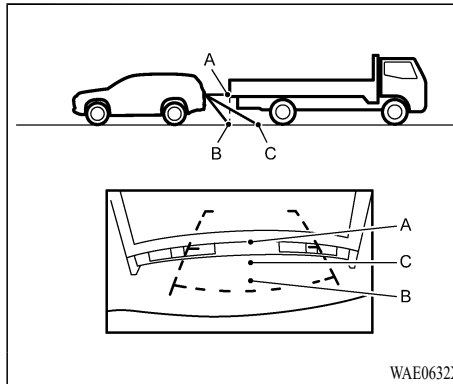

Backing up behind a projecting object

When there is an object behind the vehicle that has upper sections projecting in the direction of the vehicle, the reference lines on the screen will indicate that point A is the farthest point and point B is the closest point to the vehicle. In reality, point A and B are actually the same distance from the vehicle, and point C is farther off than point A and B.

HOW TO PARK WITH PREDICTIVE COURSE LINES

WARNING

- If the tires are replaced with different sized tires, the predictive course lines may be displayed incorrectly.
- On a snow-covered or slippery road, there may be a difference between the predictive course line and the actual course line.
- If the battery is disconnected or becomes discharged, the predictive course lines may be displayed incorrectly. If this occurs, please perform the following procedures:
 - Turn the steering wheel from lock to lock while the engine is running.
 - Drive the vehicle on a straight road for more than 5 minutes.
- When the steering wheel is turned with the ignition switch in the ON position, the predictive course lines may be displayed incorrectly.

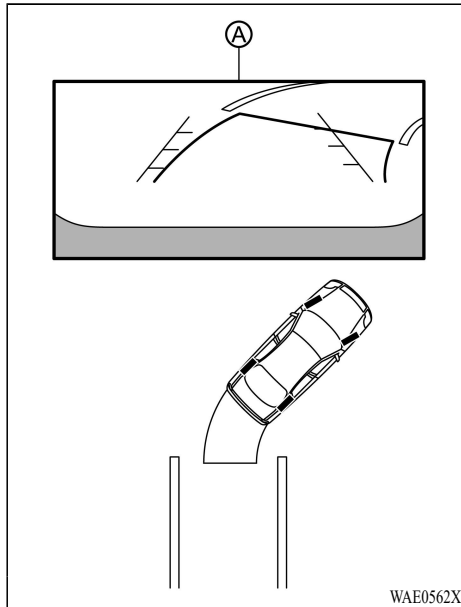

1. Visually check that the parking space is safe before parking your vehicle.
2. The rear view of the vehicle is displayed on the screen (A) when the shift lever is moved to the R (Reverse) position.

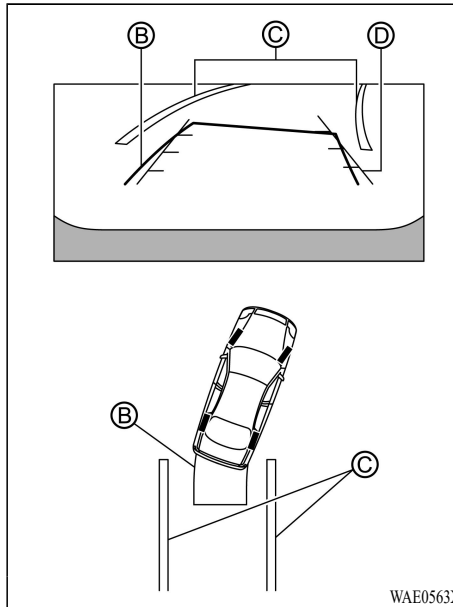

3. Slowly back up the vehicle adjusting the steering wheel so that the predictive course lines (B) enter the parking space (C).
4. Maneuver the steering wheel to make the vehicle width guide lines (D) parallel to the parking space (C) while referring to the predictive course lines.

5. When the vehicle is parked in the space completely, move the shift lever to the P (Park) position and apply the parking brake.

HOW TO SWITCH THE DISPLAY

With the ignition switch placed in the ON position, push the CAMERA button or move the shift lever to the R (Reverse) position to operate the Multi Around Monitor.

The Multi Around Monitor displays different split screen views depending on the position of the shift lever. Push the CAMERA button to switch between the available views.

If the shift lever is in the R (Reverse) position, the available views are:

- Rear view/bird's-eye view split screen
- Rear view/front-side view split screen
- Rear view

If the shift lever is in the out of R (Reverse) position, the available views are:

- Front view/bird's-eye view split screen
- Front view/front-side view split screen

The display will switch from the Multi Around Monitor screen when:

- The shift lever is in the D (Drive) position and the vehicle speed increases above approximately 6 MPH (10 km/h).

- A different screen is selected.

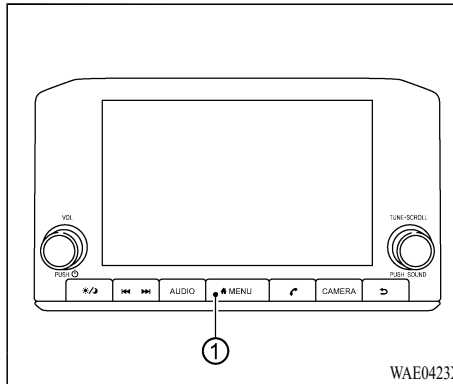

ADJUSTING THE SCREEN

1. Push the MENU button ①.
2. Touch the “Settings” key and then touch the “Camera” key.
3. Touch the “Display Settings” key.
4. Touch the “Brightness”, “Contrast”, “Tint”, “Color”, or “Black Level” key.
5. Adjust the item by touching the “+” or “-” key on the touch screen display.

NOTE:

Do not adjust the display settings of the Multi Around Monitor while the vehicle is moving. Make sure the parking brake is firmly applied.

HOW TO TURN ON AND OFF PREDICTIVE COURSE LINES

To turn the predictive course lines on and off when the shift lever is in the P (Park) position, perform the following operation.

1. Push the MENU button
2. Touch the “Settings” key and then touch the “Camera” key.
3. Touch the “Predictive Course Lines” key to turn the feature ON or OFF.

Pushing the CAMERA button while the shift lever is in the R (Reverse) position can also turn on and off the predictive course lines.

MULTI AROUND MONITOR SYSTEM LIMITATIONS

WARNING

Listed below are the system limitations for Multi Around Monitor. Failure to operate the vehicle in accordance with these system limitations could result in serious injury or death.

- Do not use the Multi Around Monitor with the door mirrors in the stored position, and make sure that the liftgate is securely closed when operating the vehicle using the Multi Around Monitor.

- The apparent distance between objects viewed on the Multi Around Monitor differs from the actual distance.
- The cameras are installed above the front grille, the door mirrors and above the rear license plate. Do not put anything on the cameras.
- When washing the vehicle with high-pressure water, be sure not to spray it around the cameras. Otherwise, water may enter the camera unit causing water condensation on the lens, a malfunction, fire or an electric shock.
- Do not strike the cameras. They are precision instruments. Doing so could cause a malfunction or cause damage resulting in a fire or an electric shock.

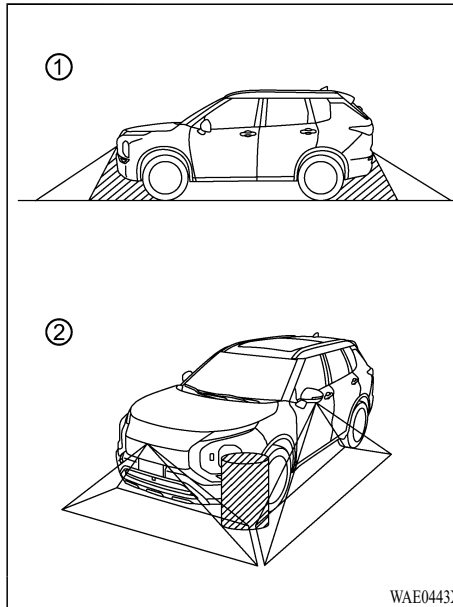

There are some areas where the system will not show objects and the system does not warn of moving objects. When in the front or the rear view display, an object below the bumper or on the ground may not be viewed ①. When in the bird's-eye view, a tall object near the seam ② of the camera viewing areas will not appear in the monitor.

The following are operating limitations and do not represent a system malfunction:

- There may be a delay when switching between views.
- When the temperature is extremely high or low, the screen may not display objects clearly.
- When strong light directly shines on the camera, objects may not be displayed clearly.
- The screen may flicker under fluorescent light.
- The colors of objects on the Multi Around Monitor may differ somewhat from the actual color of objects.
- Objects on the Multi Around Monitor may not be clear and the color of the object may differ in a dark environment.
- There may be differences in sharpness between each camera view of the bird's-eye view.
- Do not use wax on the camera lens. Wipe off any wax with a clean cloth that has been dampened with a diluted mild cleaning agent, then wipe with a dry cloth.

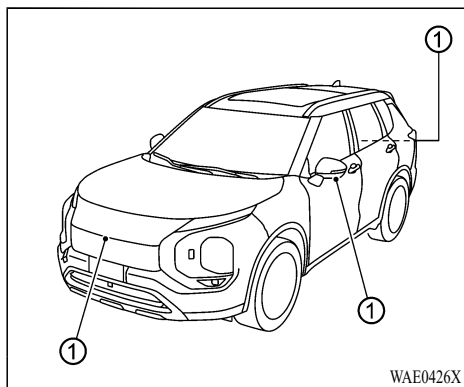

cloth.

SYSTEM MAINTENANCE

CAUTION

- Do not use alcohol, benzine or thinner to clean the camera. This will cause discoloration.
- Do not damage the camera as the monitor screen may be adversely affected.

If dirt, rain or snow accumulates on any of the cameras ①, the Multi Around Monitor may not display objects clearly. Clean the camera by wiping with a cloth dampened with a diluted mild cleaning agent and then wiping with a dry

4-22 Monitor, heater, air conditioner, audio and phone systems

MOVING OBJECT DETECTION (MOD) (if so equipped)

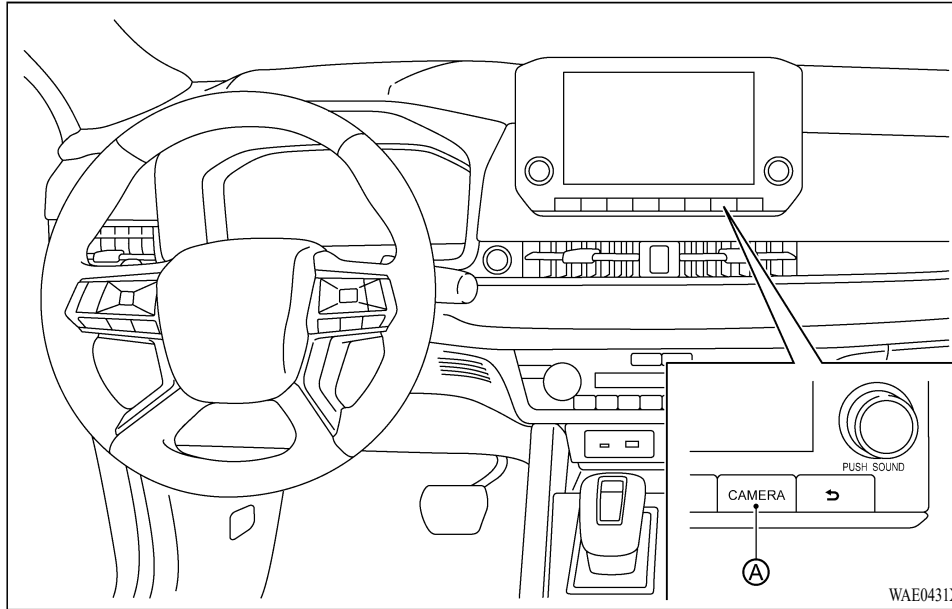

A CAMERA button

WARNING

- Failure to follow the warnings and instructions for proper use of the Moving Object Detection system could result in serious

injury or death.

- The MOD system is not a substitute for proper vehicle operation and is not designed to prevent contact with objects surrounding the vehicle. When maneuvering, always use the door mirror and rearview mirror and turn and check the

surroundings to ensure it is safe to maneuver.

- The system is deactivated at speeds above 6 MPH (10 km/h). It is reactivated at lower speeds.
- The MOD system is not designed to detect the surrounding stationary objects.

The MOD system can inform the driver of moving objects near the vehicle when driving out of garages, maneuvering in parking lots and in other such instances.

The MOD system detects moving objects by using image processing technology on the image shown in the display.

MOD SYSTEM OPERATION

The MOD system will turn on automatically under the following conditions:

- When the shift lever is in the R (Reverse) position.
- When the CAMERA button is pushed to activate the Multi Around Monitor system on the display.
- When vehicle speed decreases below approximately 6 MPH (10 km/h).

The MOD system operates in the following conditions when the camera view is displayed:

- When the shift lever is in the P (Park) or N (Neutral) position and the vehicle is stopped, the MOD system detects the moving objects in the bird's-eye view. The MOD system will not operate if either door is opened. If door mirrors are folded, MOD may not operate properly.
- When the shift lever is in the D (Drive) position, and the vehicle speed is below approximately 6 MPH (10 km/h), the MOD system detects moving objects in the front view.
- When the shift lever is in the R (Reverse) position and the vehicle speed is below approximately 6 MPH (10 km/h), the MOD system detects moving objects in the rear view. The MOD system will not operate if the liftgate is open.

The MOD system does not detect moving objects in the front-side view. The MOD icon is not displayed on the screen when in this view.

When the MOD system detects a moving object near the vehicle, the yellow frame will be displayed on the view where the object is detected and a chime will sound once. While the MOD system continues to detect moving objects, the yellow frame continues to be displayed.

NOTE:

While the RCTA chime is beeping, the MOD system does not chime.

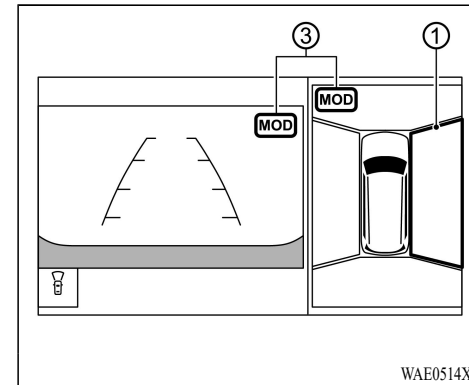

Front and bird's-eye views

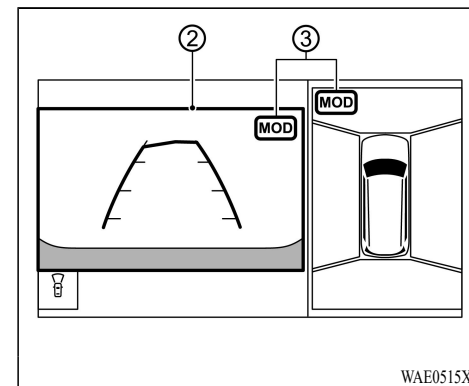

Rear and bird's-eye views

4-24 Monitor, heater, air conditioner, audio and phone systems

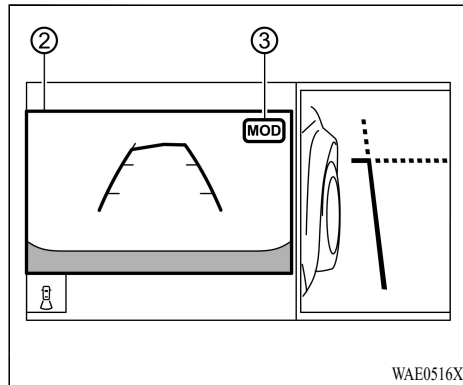

Rear and front-side views

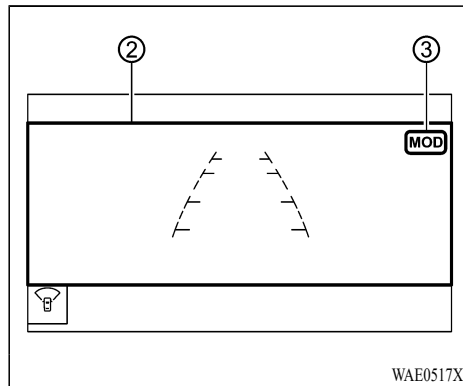

Front-wide view / rear-wide view

In the bird's-eye view, the yellow frame ① is displayed on each camera image (front, rear, right, left) depending on where moving objects are detected.

The yellow frame ② is displayed on each view in the front view and rear view modes.

A green MOD icon ③ is displayed in the view where the MOD system is operative. A gray MOD icon ③ is displayed in the view where the MOD system is not operative.

If the MOD system is turned off, the MOD icon ③ is not displayed.

TURNING MOD ON AND OFF

The MOD system can be turned on and off using the multi-information display. (See "Driver Assistance" (P.2-23).)

MOD SYSTEM LIMITATIONS

WARNING

Listed below are the system limitations for MOD. Failure to operate the vehicle in accordance with these system limitations could result in serious injury or death.

- Excessive noise (for example, audio system volume or open vehicle window) will interfere with the chime sound, and it may not be heard.

- The MOD system performance will be limited according to environmental conditions and surrounding objects such as:

- When there is low contrast between background and the moving objects.

- When there is blinking source of light.

- When strong light such as another vehicle's headlight or sunlight is present.

- When camera orientation is not in its usual position, such as when the door mirror is folded.

- When there is dirt, water drops or snow on the camera lens.

- When the position of the moving objects in the display is not changed.

- The MOD system might detect flowing water droplets on the camera lens, white smoke from the muffler, moving shadows, etc.

- The MOD system may not function properly depending on the speed, direction, distance or shape of the moving objects.

- If your vehicle sustains damage to the parts where the camera is installed, leaving

it misaligned or bent, the sensing zone may be altered and the MOD system may not detect objects properly.

- When the temperature is extremely high or low, the screen may not display objects clearly. This is not a malfunction.

NOTE:

The green MOD icon will change to orange if one of the following has occurred.

- When the system is malfunctioning.
- When the component temperature reaches a high level (icon will blink).
- When the rearview camera has detected a blockage (icon will blink).

If the icon light continues to illuminate in orange, have the MOD system checked. It is recommended that you visit an authorized Mitsubishi Motors dealer for this service.

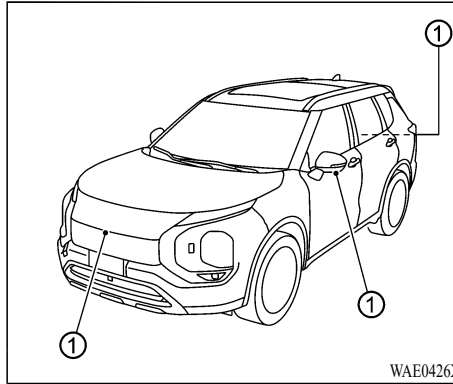

SYSTEM MAINTENANCE

CAUTION

- Do not use alcohol, benzine or thinner to clean the camera. This will cause discoloration.
- Do not damage the camera as the monitor screen may be adversely affected.

If dirt, rain or snow accumulates on any of the cameras ①, the MOD system may not operate properly. Clean the camera by wiping with a cloth dampened with a diluted mild cleaning agent and then wiping with a dry cloth.

VENTILATORS

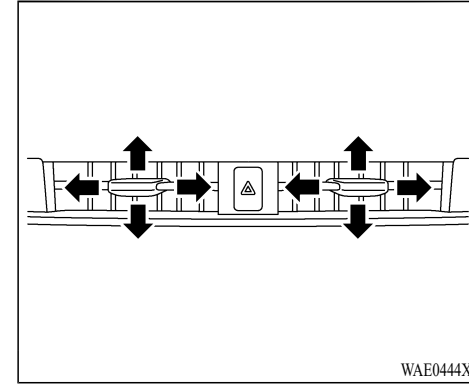

CENTER VENTILATORS

Adjust the air flow direction of the ventilators by moving the center knob (up/down, left/right) until the desired position is achieved.

To close the vent, fully move the knob to the outer side.

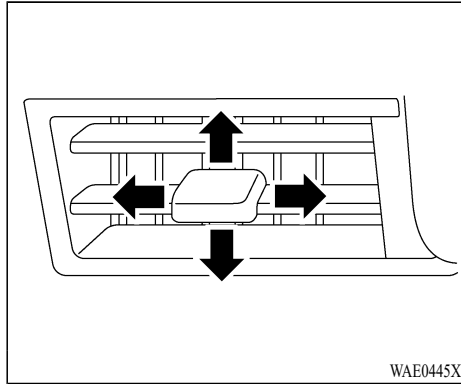

SIDE VENTILATORS

Adjust the air flow direction of the ventilators by moving the center knob (up/down, left/right) until the desired position is achieved.

To close the vent, fully move the knob to the outer side.

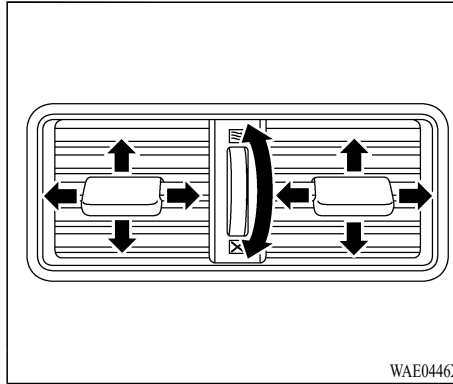

REAR VENTILATORS

Open/close the ventilators by moving the control to either direction.

- ☐ : This symbol indicates that the ventilators are open. Moving the side control to this direction will open the ventilators.
- ☒ : This symbol indicates that the ventilators are closed. Moving the side control to this direction will close the ventilators.

Adjust the air flow direction of the ventilators by moving the center knob (up/down, left/right) until the desired position is achieved.

HEATER AND AIR CONDITIONER

WARNING

- The heater and air conditioner operate only when the engine is running.
- Never leave children or adults who would normally require the support of others alone in the vehicle. Pets should not be left alone either. They could unknowingly activate switches or controls and inadvertently become involved in a serious accident and injure themselves. On hot, sunny days, temperatures in a closed vehicle could quickly become high enough to cause severe or possibly fatal injuries to people or animals.
- Do not use the recirculation mode for long periods as it may cause the interior air to become stale and the windows to fog up.
- Do not adjust the heating and air conditioning controls while driving so that full attention may be given to vehicle operation.

CAUTION

The engine speed may increase when the air conditioning is operating. With an increased engine speed, a Continuously Variable Transmission (CVT) vehicle will creep to a greater





degree than with a lower engine speed. Fully depress the brake pedal to prevent the vehicle from creeping.

The heater and air conditioner operate when the engine is running. The air blower will operate even if the engine is turned off and the ignition switch is placed in the ON position.

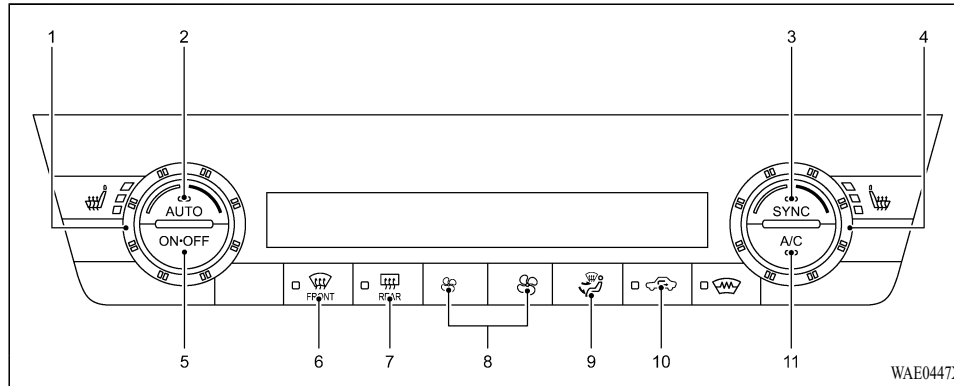
NOTE:

- Odors from inside and outside the vehicle can build up in the air conditioner unit. Odor can enter the passenger compartment through the ventilators.
- When parking, set the heater and air conditioner controls to turn off air recirculation to allow fresh air into the passenger compartment. This should help reduce odors inside the vehicle.



1. Temperature control dial (driver's side)
2. AUTO (automatic) button
3. SYNC (synchronize) button
4. Temperature control dial (passenger's side)
5. ON-OFF button
6.  (front defroster) button
7.  (electric rear window defroster) button
(See "Electric rear window and door mirror defroster switch" (P.2-52).)
8.  (fan speed control) buttons
9.  (air flow control) button
10.  (air recirculation) button
11. A/C (air conditioner) button

DUAL-ZONE AUTOMATIC CLIMATE CONTROL

Automatic operation

Cooling and/or dehumidified heating (AUTO):

This mode may be used all year round as the system automatically works to keep a constant temperature. Air flow distribution and fan speed are also controlled automatically.

1. Push the AUTO button on. (The indicator on the button will illuminate.)
2. Turn the temperature control dial on the corresponding side to set the desired

temperature.

- You can individually set temperatures for the driver's side and front passenger's side when the indicator light on the SYNC button is not illuminated.

A visible mist may be seen coming from the ventilators in hot, humid conditions as the air is cooled rapidly. This does not indicate a malfunction.

Heating (A/C OFF):



The air conditioner does not activate in this mode. Use this mode when you only need to heat.

1. Push the AUTO button on. (The indicator on the button will illuminate.)
2. Push the A/C button. (The indicator light will turn off.)
3. Turn the temperature control dial on the corresponding side to set the desired temperature.
 - You can individually set temperatures for the driver's side and front passenger's side when the indicator light on the SYNC button is not illuminated.
 - The temperature of the passenger compartment will be maintained automatically. Air flow distribution and fan speed are also controlled automatically.

NOTE:

- **Do not set the temperature lower than the outside air temperature or the system may not work properly.**
- **Not recommended if windows fog up.**

Dehumidified defrosting or defogging:

1. Push the  button on. (The indicator light on the button will come on.)
2. Turn the temperature control dial on the corresponding side to set the desired temperature.
 - As soon as possible after the windshield is clean, push the AUTO button to return to the automatic mode.
 - When the  button is pushed, the air conditioner will automatically be turned on at outside temperatures above 35°F (2°C). The air recirculation mode automatically turns off, allowing outside air to be drawn into the passenger compartment to further improve the defogging performance.

Manual operation**Fan speed control:**

Push the  buttons to manually control the fan speed.





Air intake control:

The air intake control mode will change each time the  button is pushed.

- When the indicator light is turned on, the air recirculates inside the vehicle.
- When the indicator light is turned off, the air flow is drawn from outside the vehicle.
- To switch to automatic control mode, push and hold the  button for approximately 2 seconds. The indicator light will flash twice, and then the air intake will be controlled automatically.

Air flow control:

Pushing the  button manually controls air flow and selects the air outlet:

-  — Air flows mainly from center and side ventilators.
-  — Air flows mainly from center and side ventilators and foot outlets.
-  — Air flows mainly from the foot outlet and partly from the defroster.
-  — Air flows mainly from the defroster and foot outlets.
-  — Air flows mainly from the defroster.

Synchronize temperature settings:

Push the SYNC button to synchronize the driver's and passenger's side temperature settings. The sync indicator light will turn on.

When the SYNC mode is active, the driver's side temperature control dial will control the driver's and front passenger's side temperatures.

To exit the SYNC mode, push the SYNC button again or turn the passenger's side temperature control dial.

To turn the system off

Push the ON·OFF button.

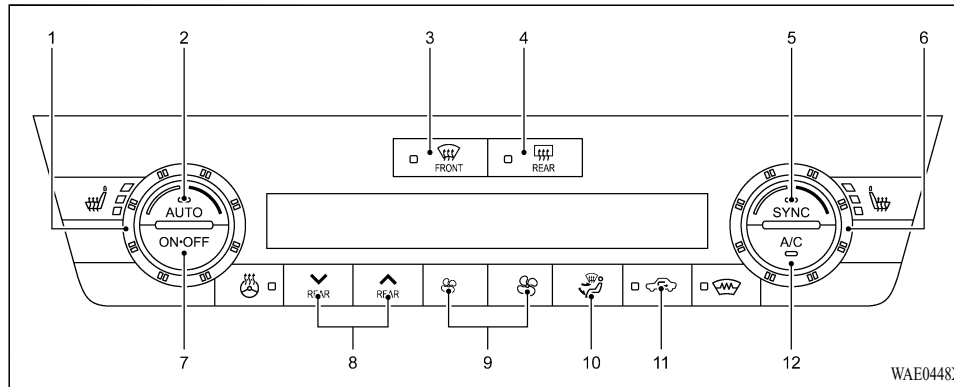

1. Temperature control dial (driver's side)
2. AUTO (automatic) button
3. (front defroster) button
4. (electric rear window defroster) button
(See "Electric rear window and door mirror defroster switch" (P.2-52).)
5. SYNC (synchronize) button
6. Temperature control dial (passenger's side)
7. ON·OFF button
8. Rear temperature control buttons
9. (fan speed control) buttons
10. (air flow control) button
11. (air recirculation) button
12. A/C (air conditioner) button

3-ZONE AUTOMATIC CLIMATE CONTROL

Automatic operation

Cooling and/or dehumidified heating (AUTO):

This mode may be used all year round as the system automatically works to keep a constant temperature. Air flow distribution and fan speed are also controlled automatically.

1. Push the AUTO button on. (The indicator on the button will illuminate.)
2. Turn the temperature control dial on the corresponding side to set the desired

temperature.

- You can individually set temperatures for the driver's side and front passenger's side when the indicator light on the SYNC button is not illuminated.

A visible mist may be seen coming from the ventilators in hot, humid conditions as the air is cooled rapidly. This does not indicate a malfunction.

Heating (A/C OFF):



The air conditioner does not activate in this mode. Use this mode when you only need to heat.

1. Push the AUTO button on. (The indicator on the button will illuminate.)
2. Push the A/C button. (The indicator light will turn off.)
3. Turn the temperature control dial on the corresponding side to set the desired temperature.
 - You can individually set temperatures for the driver's side and front passenger's side when the indicator light on the SYNC button is not illuminated.
 - The temperature of the passenger compartment will be maintained automatically. Air flow distribution and fan speed are also controlled automatically.

NOTE:

- **Do not set the temperature lower than the outside air temperature or the system may not work properly.**
- **Not recommended if windows fog up.**

Dehumidified defrosting or defogging:

1. Push the  button on. (The indicator light on the button will come on.)
2. Turn the temperature control dial on the corresponding side to set the desired temperature.
 - As soon as possible after the windshield is clean, push the AUTO button to return to the automatic mode.
 - When the  button is pushed, the air conditioner will automatically be turned on at outside temperatures above 35°F (2°C). The air recirculation mode automatically turns off, allowing outside air to be drawn into the passenger compartment to further improve the defogging performance.

Manual operation**Fan speed control:**

Push the  buttons to manually control the fan speed.





Air intake control:

The air intake control mode will change each time the  button is pushed.

- When the indicator light is turned on, the air recirculates inside the vehicle.
- When the indicator light is turned off, the air flow is drawn from outside the vehicle.
- To switch to automatic control mode, push and hold the  button for approximately 2 seconds. The indicator light will flash twice, and then the air intake will be controlled automatically.

Air flow control:

Pushing the  button manually controls air flow and selects the air outlet:

-  — Air flows mainly from center and side ventilators.
-  — Air flows mainly from center and side ventilators and foot outlets.
-  — Air flows mainly from the foot outlet and partly from the defroster.
-  — Air flows mainly from the defroster and foot outlets.
-  — Air flows mainly from the defroster.

Synchronize temperature settings:

Push the SYNC button to synchronize the driver's side, passenger's side and rear temperature settings. The indicator light on the SYNC button will turn on.

When the SYNC mode is active, the driver's side temperature control dial will control the driver's side, front passenger's side and rear temperatures.

To exit the SYNC mode, push the SYNC button again or turn the passenger's side temperature control dial.

To turn the system off

Push the ON·OFF button.

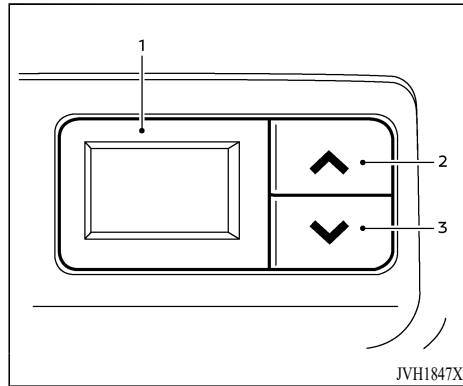

1. Rear temperature display
2. “ ^ ” Rear temperature increase button
3. “ v ” Rear temperature decrease button

Rear temperature control

You can adjust the temperature for rear seat passengers using the buttons located on the rear console.

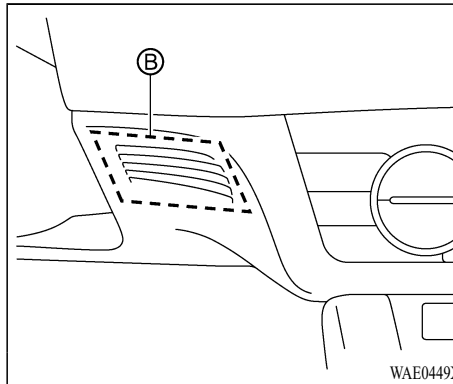
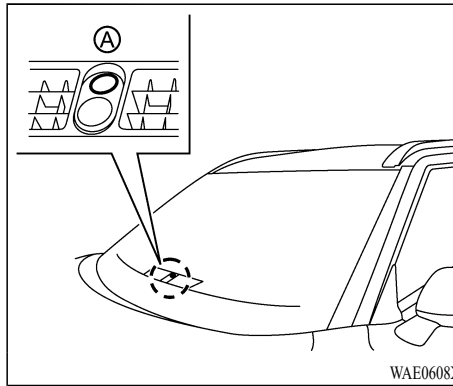

OPERATING TIPS

When the engine coolant temperature and outside air temperature are low, the air flow from the foot outlets may not operate. However, this is not a malfunction. After the coolant temperature warms up, air flow from the foot outlets will operate normally.

The sensors **A** and **B**, located on the instrument panel, help maintain a constant temperature. Do not put anything on or around the sensors.

SERVICING AIR CONDITIONER

WARNING

The air conditioner system contains refrigerant under high pressure. To avoid personal injury, any air conditioner service should be done only by an experienced technician with the proper equipment.

The air conditioner system in your vehicle is charged with a refrigerant designed with the environment in mind.

This refrigerant will not harm the earth's ozone layer. However, it may contribute in a small part to global warming.

Special charging equipment and lubricant are

ANTENNA

required when servicing your vehicle's air conditioner. Using improper refrigerants or lubricants will cause severe damage to the air conditioner system. (See "Air conditioning system refrigerant and lubricant recommendations" (P.10-6).)

A authorized Mitsubishi Motors dealer will be able to service your environmentally friendly air conditioner system.

Micron air filtration

The air conditioner system is equipped with a Micron air filtration. To make sure the air conditioner heats, defogs, and ventilates efficiently, replace the filter according the specified maintenance intervals. It is recommended to visit an authorized Mitsubishi Motors dealer to replace the filter.

The filter should be replaced if the air flow decreases significantly or if windows fog up easily when operating the heater or air conditioner.

SHARK FIN ANTENNA

The shark fin antenna is located on the rear part of the vehicle roof.

CAR PHONE OR CB RADIO

When installing a car phone or a CB radio in your vehicle, be sure to observe the following precautions, otherwise the new equipment may adversely affect the electronic control modules and electronic control system harness.

WARNING

- A cellular phone should not be used for any purpose while driving so full attention may be given to vehicle operation. Some jurisdictions prohibit the use of cellular phones while driving.
- If you must make a call while your vehicle is in motion, the hands-free cellular phone operational mode (if so equipped) is highly recommended. Exercise extreme caution at all times so full attention may be given to vehicle operation.
- If a conversation in a moving vehicle requires you to take notes, pull off the road to a safe location and stop your vehicle before doing so.

CAUTION

- Keep the antenna as far away as possible from the electronic control modules.

- **Keep the antenna wire more than 8 in (20 cm) away from the electronic control system harness. Do not route the antenna wire next to any harness.**
- **Adjust the antenna standing-wave ratio as recommended by the manufacturer.**
- **Connect the ground wire from the CB radio chassis to the body.**
- **For details, it is recommended you visit an authorized Mitsubishi Motors dealer.**

(250,1)

MEMO

4-36 Monitor, heater, air conditioner, audio and phone systems

Condition:

[Edit: 2021/ 2/ 10 Model: DG-D]

5 Starting and driving

Precautions when starting and driving	5-5	Brake Auto Hold	5-25
Exhaust gas (carbon monoxide)	5-5	How to activate/deactivate the Brake Auto	
Three-way catalyst	5-5	Hold function	5-26
Tire Pressure Monitoring System (TPMS)	5-6	How to use the Brake Auto Hold function	5-27
Avoiding collision and rollover	5-9	Drive Mode Selector	5-28
On-pavement and off-road driving precautions	5-10	NORMAL mode	5-29
Off-road recovery	5-10	ECO mode	5-29
Rapid air pressure loss	5-10	TARMAC mode	5-30
Drinking alcohol/drugs and driving	5-11	GRAVEL mode	5-30
Driving safety precautions	5-11	SNOW mode	5-30
Push-button ignition switch	5-13	MUD mode (AWC model)	5-30
Operating range for engine start function	5-13	Traffic Sign Recognition (TSR) (if so equipped)	5-30
Push-button ignition switch operation	5-14	System operation	5-31
Push-button ignition switch positions	5-14	How to enable/disable the TSR system	5-32
Emergency engine shut off	5-15	System temporarily unavailable	5-32
F.A.S.T.-key battery discharge	5-15	System malfunction	5-32
Before starting the engine	5-16	System maintenance	5-33
Starting the engine	5-16	Lane Departure Warning (LDW)	5-33
Driving the vehicle	5-17	LDW system operation	5-34
Continuously Variable Transmission (CVT)	5-17	How to enable/disable the LDW system	5-35
Parking brake	5-23	LDW system limitations	5-35
Automatic operation	5-24	System temporarily unavailable	5-36
Manual operation	5-24	System malfunction	5-37
		System maintenance	5-37

Lane Departure Prevention (LDP) (if so equipped)	5-38	System temporarily unavailable	5-67
LDP system operation	5-39	System malfunction	5-68
How to enable/disable the LDP system	5-40	System maintenance	5-68
LDP system limitations	5-40	Cruise control (if so equipped)	5-69
System temporarily unavailable	5-42	Precautions on cruise control	5-69
System malfunction	5-42	Cruise control operations	5-70
System maintenance	5-43	Adaptive Cruise Control System (ACC) (if	
Blind Spot Warning (BSW)	5-43	so equipped)	5-71
BSW system operation	5-45	How to select the cruise control mode	5-73
How to enable/disable the BSW system	5-46	Vehicle-to-vehicle distance control mode	5-73
BSW system limitations	5-46	Conventional (fixed speed) cruise	
BSW driving situations	5-47	control mode	5-87
System temporarily unavailable	5-50	MI-PILOT Assist (if so equipped)	5-90
System malfunction	5-50	MI-PILOT Assist system operation	5-92
System maintenance	5-50	MI-PILOT Assist switches	5-94
Active Blind Spot Assist (ABSA) (if so equipped)	5-51	MI-PILOT Assist system display	
ABSA system operation	5-53	and indicators	5-95
How to enable/disable the ABSA system	5-54	Turning the conventional (fixed speed) cruise	
ABSA system limitations	5-55	control mode ON	5-97
ABSA driving situations	5-56	Operating MI-PILOT Assist	5-98
System temporarily unavailable	5-60	How to enable/disable the Lane Keep	
System malfunction	5-60	Assist (LKA)	5-102
System maintenance	5-61	How to cancel the MI-PILOT Assist system	5-103
Rear Cross Traffic Alert (RCTA)	5-62	Adaptive Cruise Control System (ACC) with	
RCTA system operation	5-63	Stop & Go	5-103
How to enable/disable the RCTA system	5-65	Lane Keep Assist (LKA)	5-117
RCTA system limitations	5-66	Conventional (fixed speed) cruise	
		control mode	5-122

Forward Collision Mitigation System (FCM)	5-126	S-AWC (Super-All Wheel Control) (if so equipped)	5-153
FCM system operation	5-127	Electronically Controlled AWC	5-153
Turning the FCM system ON/OFF	5-128	Active Yaw Control (AYC)	5-153
FCM system limitations	5-129	S-AWC operation display	5-153
System temporarily unavailable	5-132	Parking/parking on hills	5-155
System malfunction	5-133	Electric power steering	5-156
System maintenance	5-133	Brake system	5-156
Predictive Forward Collision Warning (PFCW)	5-135	Braking precautions	5-156
PFCW system operation	5-137	Brake assist	5-157
Turning the PFCW system ON/OFF	5-138	Brake assist	5-157
PFCW system limitations	5-140	Anti-lock Braking System (ABS)	5-157
System temporarily unavailable	5-141	Active stability control (ASC)	5-159
System malfunction	5-142	How to turn off the ASC	5-160
System maintenance	5-142	Chassis control	5-160
Driver Attention Alert (DAA)	5-143	Active Yaw Control (AYC)	5-160
DAA system operation	5-144	Active Ride Control	5-161
How to enable/disable the DAA system	5-145	Hill Start Assist (HSA)	5-161
DAA system limitations	5-145	Hill Descent Control (HDC)	5-162
Rear Automatic Emergency Braking (Rear AEB)	5-146	To operate	5-163
Rear AEB system operation	5-147	To deactivate	5-163
Turning the Rear AEB system ON/OFF	5-148	Parking sensor system (if so equipped)	5-164
Rear AEB system limitations	5-148	System operation	5-165
System malfunction	5-150	How to enable/disable the parking sensor system	5-166
System maintenance	5-151	Parking sensor system limitations	5-167
Break-in schedule	5-151	System temporarily unavailable	5-167
Fuel Efficient Driving Tips	5-152	System maintenance	5-168
Increasing fuel economy	5-153		

Rear parking sensor system (if so equipped)	5-169	Cold weather driving	5-173
System operation	5-170	Freeing a frozen door lock	5-173
How to enable/disable the rear parking sensor	5-171	Anti-freeze	5-173
Rear parking sensor limitations	5-172	Battery	5-173
System temporarily unavailable	5-172	Draining of coolant water	5-173
System maintenance	5-173	Tire equipment	5-174
		Special winter equipment	5-174
		Driving on snow or ice	5-174

PRECAUTIONS WHEN STARTING AND DRIVING

WARNING

- Do not leave children or adults who would normally require the support of others alone in your vehicle. Pets should not be left alone either. They could accidentally injure themselves or others through inadvertent operation of the vehicle. Also, on hot, sunny days, temperatures in a closed vehicle could quickly become high enough to cause severe or possibly fatal injuries to people or animals.
- Properly secure all cargo with ropes or straps to help prevent it from sliding or shifting. Do not place cargo higher than the seatbacks. In a sudden stop or collision, unsecured cargo could cause personal injury.

EXHAUST GAS (carbon monoxide)

WARNING

- Do not breathe exhaust gas; it contains colorless and odorless carbon monoxide. Carbon monoxide is dangerous. It can cause unconsciousness or death.

- If you suspect that exhaust fumes are entering the vehicle, drive with all windows fully open, and have the vehicle inspected immediately.
- Do not run the engine in closed spaces such as a garage.
- Do not park the vehicle with the engine running for an extended period of time.
- Keep the liftgate closed while driving, otherwise exhaust gas could be drawn into the passenger compartment. If you must drive with the liftgate open, follow these precautions:
 - Open all the windows.
 - Turn the air recirculation mode off and set the fan speed control to the highest level to circulate the air.
- If a special body or other equipment is added for recreational or other usage, follow the manufacturer's recommendation to prevent carbon monoxide entry into the vehicle. (Some recreational vehicle appliances such as stoves, refrigerators, heaters, etc. may also generate carbon monoxide.)
- The exhaust system and body should be inspected by a qualified mechanic whenever:

- Your vehicle is raised while being serviced.
- You suspect that exhaust fumes are entering into the passenger compartment.
- You notice a change in the sound of the exhaust system.
- You have had an accident involving damage to the exhaust system, underbody, or rear of the vehicle.

THREE-WAY CATALYST

The three-way catalyst is an emission control device installed in the exhaust system. Exhaust gases in the three-way catalyst are burned at high temperatures to help reduce pollutants.

WARNING

- The exhaust gas and the exhaust system are very hot. Keep people, animals and flammable materials away from the exhaust system components.
- Do not stop or park the vehicle over flammable materials such as dry grass, wastepaper or rags. They may ignite and cause a fire.

CAUTION

- Do not use leaded gasoline. Deposits from leaded gasoline will seriously reduce the three-way catalyst's ability to help reduce exhaust pollutants.
- Keep your engine tuned up. Malfunctions in the ignition, fuel injection, or electrical systems can cause overrich fuel flow into the three-way catalyst, causing it to overheat. Do not keep driving if the engine misfires, or if noticeable loss of performance or other unusual operating conditions are detected. Have the vehicle inspected. It is recommended you visit an authorized Mitsubishi Motors dealer for this service.
- Avoid driving with an extremely low fuel level. Running out of fuel could cause the engine to misfire, damaging the three-way catalyst.
- Do not race the engine while warming it up.
- Do not push or tow your vehicle to start the engine.

TIRE PRESSURE MONITORING SYSTEM (TPMS)



Low tire pressure warning light

Each tire, including the spare (if provided), should be checked monthly when cold and inflated to the inflation pressure recommended by the vehicle manufacturer on the vehicle placard or tire inflation pressure label. (If your vehicle has tires of a different size than the size indicated on the vehicle placard or tire inflation pressure label, you should determine the proper tire inflation pressure for those tires.)

As an added safety feature, your vehicle has been equipped with a tire pressure monitoring system (TPMS) that illuminates a low tire pressure telltale when one or more of your tires is significantly under-inflated. Accordingly, when the low tire pressure telltale illuminates, you should stop and check your tires as soon as possible, and inflate them to the proper pressure. Driving on a significantly under-inflated tire causes the tire to overheat and can lead to tire failure. Under-inflation also reduces fuel efficiency and tire tread life, and may affect the vehicle's handling and stopping ability.

Please note that the TPMS is not a substitute for proper tire maintenance, and it is the driver's responsibility to maintain correct tire pressure,

even if under-inflation has not reached the level to trigger illumination of the TPMS low tire pressure telltale.

Your vehicle has also been equipped with a TPMS malfunction indicator to indicate when the system is not operating properly. The TPMS malfunction indicator is combined with the low tire pressure telltale. When the system detects a malfunction, the telltale will flash for approximately one minute and then remain continuously illuminated. This sequence will continue upon subsequent vehicle start-ups as long as the malfunction exists. When the malfunction indicator is illuminated, the system may not be able to detect or signal low tire pressure as intended. TPMS malfunctions may occur for a variety of reasons, including the installation of replacement or alternate tires or wheels on the vehicle that prevent the TPMS from functioning properly. Always check the TPMS malfunction telltale after replacing one or more tires or wheels on your vehicle to ensure that the replacement or alternate tires and wheels allow the TPMS to continue to function properly.

Whenever the tires and wheels are replaced with new ones

If new wheels with new tire inflation pressure sensors are installed, their ID codes must be programmed into the tire pressure monitoring system. Have tire and wheel replacement performed by an authorized Mitsubishi Motors dealer to avoid the risk of damaging the tire inflation pressure sensors. If the wheel replacement is not done by an authorized Mitsubishi Motors dealer, it is not covered by your warranty.

Additional information

- The TPMS will activate only when the vehicle is driven at speeds above 16 MPH (25 km/h). Also, this system may not detect a sudden drop in tire pressure (for example a flat tire while driving).
- The low tire pressure warning light does not automatically turn off when the tire pressure is adjusted. After the tire is inflated to the recommended pressure, the vehicle must be driven at speeds above 16 MPH (25 km/h) to activate the TPMS and turn off the low tire pressure warning light. Use a tire pressure gauge to check the tire pressure.
- The “Tire Pressure Low - Add Air”/“Tire Pressure Low - Check Cold Tire” warning appears in the multi-information display

when the low tire pressure warning light is illuminated and low tire pressure is detected. The “Tire Pressure Low - Add Air”/“Tire Pressure Low - Check Cold Tire” warning turns off when the low tire pressure warning light turns off.

The “Tire Pressure Low - Add Air”/“Tire Pressure Low - Check Cold Tire” warning does not appear if the low tire pressure warning light illuminates to indicate a TPMS malfunction.

- Tire pressure rises and falls depending on the heat caused by the vehicle’s operation and the outside temperature. Do not reduce the tire pressure after driving because the tire pressure rises after driving. Low outside temperature can lower the temperature of the air inside the tire which can cause a lower tire inflation pressure. This may cause the low tire pressure warning light to illuminate. If the warning light illuminates in low ambient temperature, check the tire pressure for all four tires.
- You can also check the tire pressure of all tires in the multi-information display. (See “Trip computer” (P.2-41).)

For additional information, see “Low tire pressure warning light” (P.2-17) and “Tire Pressure Monitoring System (TPMS)” (P.6-3).

WARNING

- If the low tire pressure warning light illuminates while driving, avoid sudden steering maneuvers or abrupt braking, reduce vehicle speed, pull off the road to a safe location and stop the vehicle as soon as possible. Driving with under-inflated tires may permanently damage the tires and increase the likelihood of tire failure. Serious vehicle damage could occur and may lead to an accident and could result in serious personal injury. Check the tire pressure for all four tires. Adjust the tire pressure to the recommended COLD tire pressure shown on the Tire and Loading Information placard to turn the low tire pressure warning light OFF. If you have a flat tire, repair it with the tire repair kit as soon as possible. (See “Flat tire” (P.6-3) for repairing a tire.)

If no tire is flat and all tires are properly inflated, it is recommended you consult an authorized Mitsubishi Motors dealer.

- When replacing a wheel without the TPMS, the TPMS will not function and the low tire pressure warning light will flash for approximately 1 minute. The light will remain on after 1 minute. Have your tires replaced and/or TPMS system reset as soon as possible. It is recommended you visit an authorized Mitsubishi Motors

dealer for these services.

CAUTION

- The TPMS may not function properly when the wheels are equipped with tire chains or the wheels are buried in snow.
- Do not place metalized film or any metal parts (antenna, etc.) on the windows. This may cause poor reception of the signals from the tire pressure sensors, and the TPMS will not function properly.

Some devices and transmitters may temporarily interfere with the operation of the TPMS and cause the low tire pressure warning light to illuminate. Some examples are:

- Facilities or electric devices using similar radio frequencies are near the vehicle.
- If a transmitter set to similar frequencies is being used in or near the vehicle.
- If a computer (or similar equipment) or a DC/AC converter is being used in or near the vehicle.

Low tire pressure warning light may illuminate in the following cases.

- If the vehicle is equipped with a wheel and tire without TPMS.

- If the TPMS has been replaced and the ID has not been registered.
- If the wheel is not originally specified by Mitsubishi Motors.

FCC Notice:

For USA:

Tire Pressure Monitoring System (TPMS) transmitter

FCC ID: KR5TIS-10DL

Body Control Module (BCM)



40406556

Continental

This device complies with Part 15 of the FCC Rules. Operation is subject to the following two conditions: (1) This device may not cause harmful interference, and (2) this device must accept any interference received, including interference that may cause undesired operation.

Note: Changes or modifications not expressly approved by the party responsible for compliance could void the user's authority to operate the equipment.

For Canada:

Tire Pressure Monitoring System (TPMS) transmitter

Continental

Model: TIS-10DL

IC: 7812D-TIS10DL

Body Control Module (BCM)

Model: 40406556

IC: 7812D-5235RXDP

Continental

This device complies with Industry Canada licence-exempt RSS standard(s). Operation is subject to the following two conditions: (1) this device may not cause interference, and (2) this device must accept any interference, including interference that may cause undesired operation of the device.

Le présent appareil est conforme aux CNR d'Industrie Canada applicables aux appareils radio exempts de licence. L'exploitation est autorisée aux deux conditions suivantes : (1) l'appareil ne doit pas produire de brouillage, et (2) l'utilisateur de l'appareil doit accepter tout brouillage radioélectrique subi, même si le brouillage est susceptible d'en compromettre le fonctionnement.

5-8 Starting and driving

TPMS with Tire fill notification

WARNING

After rotating the tires, do not use the Tire fill notification to adjust the tire pressure. Instead use a gauge to adjust the tires to the correct pressure in accordance with Tire ad Loading Information placard.

When adding air to an under-inflated tire, the TPMS with Tire fill notification provides visual and audible signals outside the vehicle to help you inflate the tires to the recommended COLD tire pressure.

Vehicle set-up:

1. Park the vehicle in a safe and level place.
2. Apply the parking brake and push the park button to shift to the P (Park) position.
3. Place the ignition switch in the ON position. Do not start the engine.

Operation:

1. Add air to the tire.
2. After a few seconds, the hazard indicators will start flashing.
3. When the designated pressure is reached, the horn beeps once and the hazard indicators stop flashing.

4. Perform the above steps for each tire.
 - If the tire is over-inflated more than approximately 4 psi (30 kPa), the horn beeps and the hazard indicators flash 3 times. To correct the pressure, push the core of the valve stem on the tire briefly to release pressure. When the pressure reaches the designated pressure, the horn beeps once.
 - If the hazard indicator does not flash within approximately 15 seconds after starting to inflate the tire, it indicates that the TPMS with Tire fill notification is not operating.
 - The TPMS will not activate the Tire fill notification under the following conditions:
 - If there is interference from an external device or transmitter
 - The air pressure from the inflation device such as those using a power socket is not sufficient to inflate the tire
 - If an electrical equipment is being used in or near the vehicle
 - There is a malfunction in the TPMS system
 - There is a malfunction in the horn or hazard indicators
 - If the TPMS with Tire fill notification does not operate due to TPMS interference, move the vehicle about 3 ft (1m) backward or forward and try again.

If the TPMS with Tire fill notification is not working, use a tire pressure gauge.

AVOIDING COLLISION AND ROLLOVER

WARNING

Failure to operate this vehicle in a safe and prudent manner may result in loss of control or an accident.

Be alert and drive defensively at all times. Obey all traffic regulations. Avoid excessive speed, high speed cornering, or sudden steering maneuvers, because these driving practices could cause you to lose control of your vehicle. **As with any vehicle, a loss of control could result in a collision with other vehicles or objects, or cause the vehicle to rollover, particularly if the loss of control causes the vehicle to slide sideways.** Be attentive at all times, and avoid driving when tired. Never drive when under the influence of alcohol or drugs (including prescription or over-the-counter drugs which may cause drowsiness). Always wear your seat belt as outlined in “Seat belts” (P.1-16) of this manual, and also instruct your passengers to do so.

Seat belts help reduce the risk of injury in

Starting and driving 5-9

collisions and rollovers. **In a rollover crash, an unbelted person is significantly more likely to die than a person wearing a seat belt.**

ON-PAVEMENT AND OFF-ROAD DRIVING PRECAUTIONS

Utility vehicles have a significantly higher rollover rate than other types of vehicles.

They have higher ground clearance than passenger cars to make them capable of performing in a variety of on-pavement and off-road applications. This gives them a higher center of gravity than ordinary cars. An advantage of higher ground clearance is a better view of the road, allowing you to anticipate problems. However, they are not designed for cornering at the same speeds as conventional passenger cars any more than low-slung sports cars are designed to perform satisfactorily under off-road conditions. If at all possible, avoid sharp turns or abrupt maneuvers, particularly at high speeds. As with other vehicles of this type, failure to operate this vehicle correctly may result in loss of control or vehicle rollover. Seat belts help reduce the risk of injury in collisions and rollovers. In a rollover crash, an unbelted person is significantly more likely to die than a person wearing a seat belt.

Be sure to read “Driving safety precautions”

(P.5-11).

OFF-ROAD RECOVERY

If the right side or left side wheels leave the road surface, maintain control of the vehicle by following the procedure below. Please note that this procedure is only a general guide. The vehicle must be driven as appropriate based on the conditions of the vehicle, road and traffic.

1. Remain calm and do not overreact.
2. Do not apply the brakes.
3. Maintain a firm grip on the steering wheel with both hands and try to hold a straight course.
4. When appropriate, slowly release the accelerator pedal to gradually slow the vehicle.
5. If there is nothing in the way, steer the vehicle to follow the road while the vehicle speed is reduced. Do not attempt to drive the vehicle back onto the road surface until vehicle speed is reduced.
6. When it is safe to do so, gradually turn the steering wheel until both tires return to the road surface. When all tires are on the road surface, steer the vehicle to stay in the appropriate driving lane.
 - If you decide that it is not safe to return the vehicle to the road surface based on vehicle, road or traffic conditions, gra-

dually slow the vehicle to a stop in a safe place off the road.

RAPID AIR PRESSURE LOSS

Rapid air pressure loss or a “blow-out” can occur if the tire is punctured or is damaged due to hitting a curb or pothole. Rapid air pressure loss can also be caused by driving on under-inflated tires.

Rapid air pressure loss can affect the handling and stability of the vehicle, especially at highway speeds.

Help prevent rapid air pressure loss by maintaining the correct air pressure and visually inspect the tires for wear and damage. See “Tires” (P.8-24) of this manual.

If a tire rapidly loses air pressure or “blows-out” while driving, maintain control of the vehicle by following the procedure below. Please note that this procedure is only a general guide. The vehicle must be driven as appropriate based on the conditions of the vehicle, road and traffic.

WARNING

The following actions can increase the chance of losing control of the vehicle if there is a sudden loss of tire air pressure. Losing control of the vehicle may cause a collision and result in personal injury.

5-10 Starting and driving

- The vehicle generally moves or pulls in the direction of the flat tire.
- Do not rapidly apply the brakes.
- Do not rapidly release the accelerator pedal.
- Do not rapidly turn the steering wheel.

1. Remain calm and do not overreact.
2. Maintain a firm grip on the steering wheel with both hands and try to hold a straight course.
3. When appropriate, slowly release the accelerator pedal to gradually slow the vehicle.
4. Gradually steer the vehicle to a safe location off the road and away from traffic if possible.
5. Lightly apply the brake pedal to gradually stop the vehicle.
6. Turn on the hazard warning flashers and either contact a roadside emergency service to change the tire or see “Tire repair kit” (P.6-3) of this Owner’s Manual.

DRINKING ALCOHOL/DRUGS AND DRIVING

WARNING

Never drive under the influence of alcohol or drugs. Alcohol in the bloodstream reduces coordination, delays reaction time and impairs judgment. Driving after drinking alcohol increases the likelihood of being involved in an accident injuring yourself and others. Additionally, if you are injured in an accident, alcohol can increase the severity of the injury.

Mitsubishi Motors is committed to safe driving. However, you must choose not to drive under the influence of alcohol. Every year thousands of people are injured or killed in alcohol-related accidents. Although the local laws vary on what is considered to be legally intoxicated, the fact is that alcohol affects all people differently and most people underestimate the effects of alcohol.

Remember, drinking and driving don’t mix! And that is true for drugs, too (over-the-counter, prescription, and illegal drugs). Don’t drive if your ability to operate your vehicle is impaired by alcohol, drugs, or some other physical condition.

DRIVING SAFETY PRECAUTIONS

Your vehicle has been designed for both normal and occasional off-road use. However, avoid driving the vehicle through areas where the tires may get stuck in deep sand or mud as your vehicle is designed primarily for use on pavement, unlike a conventional off-road vehicle.

Keep in mind that 2-wheel drive vehicles are less capable than 4-wheel drive vehicles for driving on muddy, slippery, wet or snow-covered roads.

Please observe the following precautions:

WARNING

- Drive carefully when off the road and avoid dangerous areas. Every person who drives or rides in this vehicle should be seated with their seat belt fastened. This will keep you and your passengers in position when driving over rough terrain.
- Do not drive across steep slopes. Instead drive either straight up or straight down the slopes. Off-road vehicles can tip over sideways much more easily than they can forward or backward.

- Many hills are too steep for any vehicle. If you drive up them, you may stall. If you drive down them, you may not be able to control your speed. If you drive across them, you may roll over.
- Do not shift ranges while driving on downhill grades as this could cause loss of control of the vehicle.
- Stay alert when driving to the top of a hill. At the top there could be a drop-off or other hazard that could cause an accident.
- If your engine stalls or you cannot make it to the top of a steep hill, never attempt to turn around. Your vehicle could tip or roll over. Always back straight down in R (Reverse) range. Never back down in N (Neutral), using only the brake, as this could cause loss of control.
- Heavy braking going down a hill could cause your brakes to overheat and fade, resulting in loss of control and an accident. Apply brakes lightly and use a low range to control your speed.
- Unsecured cargo can be thrown around when driving over rough terrain. Properly secure all cargo so it will not be thrown forward and cause injury to you or your passengers.
- To avoid raising the center of gravity excessively, do not exceed the rated capacity of the roof rail (if so equipped) and evenly distribute the load. Secure heavy

- loads in the cargo area as far forward and as low as possible. Do not equip the vehicle with tires larger than specified in this manual. This could cause your vehicle to roll over.
- Do not grip the inside or spokes of the steering wheel when driving off-road. The steering wheel could move suddenly and injure your hands. Instead drive with your fingers and thumbs on the outside of the rim.
- Before operating the vehicle, ensure that the driver and all passengers have their seat belts fastened.
- Always drive with the floor mats in place as the floor may become hot.
- Lower your speed when encountering strong crosswinds. With a higher center of gravity, your vehicle is more affected by strong side winds. Slower speeds ensure better vehicle control.
- Do not drive beyond the performance capability of the tires, even with AWC engaged.
- For AWC equipped vehicles, do not attempt to raise two wheels off the ground and shift the transmission to any drive or reverse position with the engine running. Doing so may result in drivetrain damage or unexpected vehicle movement which could result in serious vehicle damage or personal injury.

- Do not attempt to test an AWC equipped vehicle on a 2-wheel dynamometer (such as the dynamometers used by some states for emissions testing), or similar equipment even if the other two wheels are raised off the ground. Make sure you inform test facility personnel that your vehicle is equipped with AWC before it is placed on a dynamometer. Using the wrong test equipment may result in drivetrain damage or unexpected vehicle movement which could result in serious vehicle damage or personal injury.
- When a wheel is off the ground due to an unlevel surface, do not spin the wheel excessively (AWC model).
- Accelerating quickly, sharp steering maneuvers or sudden braking may cause loss of control.
- If at all possible, avoid sharp turning maneuvers, particularly at high speeds. Your vehicle has a higher center of gravity than a conventional passenger car. The vehicle is not designed for cornering at the same speeds as conventional passenger cars. Failure to operate this vehicle correctly could result in loss of control and/or a rollover accident.
- Always use tires of the same type, size, brand, construction (bias, bias-belted or radial), and tread pattern on all four wheels. Install traction devices on the front wheels when driving on slippery roads and

5-12 Starting and driving

PUSH-BUTTON IGNITION SWITCH

drive carefully.

- Be sure to check the brakes immediately after driving in mud or water. See “Brake system” (P.5-156) for wet brakes.
- Avoid parking your vehicle on steep hills. If you get out of the vehicle and it rolls forward, backward or sideways, you could be injured.
- Whenever you drive off-road through sand, mud or water as deep as the wheel hub, more frequent maintenance may be required.
- Spinning the front wheels on slippery surfaces may cause the AWC warning message to display and the AWC system to automatically switch from the AWC mode to the FWD mode. This could reduce traction. (AWC models)



WARNING

Do not operate the push-button ignition switch while driving the vehicle except in an emergency. (The engine will stop when the ignition switch is pushed 3 consecutive times or the ignition switch is pushed and held for more than 2 seconds.) If the engine stops while the vehicle is being driven, this could lead to a crash and serious injury.

Before operating the push-button ignition switch, be sure to push the park button to shift to the P (Park) position.

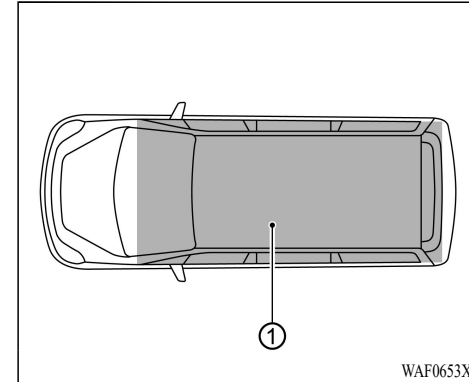

OPERATING RANGE FOR ENGINE START FUNCTION

The Free-hand Advanced Security Transmitter (F.A.S.T.-key) can only be used for starting the engine when the F.A.S.T.-key is within the specified operating range ①.

When the F.A.S.T.-key battery is almost discharged or strong radio waves are present near the operating location, the operating range becomes narrower and may not function properly.

If the F.A.S.T.-key is within the operating range, it is possible for anyone, even someone who does not carry the F.A.S.T.-key, to push the ignition switch to start the engine.

Starting and driving 5-13

- If the F.A.S.T.-key is placed on the instrument panel, inside the glove box or door pocket, the F.A.S.T.-key may not function.
- If the F.A.S.T.-key is placed near the door or window outside the vehicle, the F.A.S.T.-key may function.

PUSH-BUTTON IGNITION SWITCH OPERATION

CAUTION

- Do not leave the vehicle for extended periods of time when the ignition switch is in the ON position and the engine is not running. This can discharge the battery.
- Use electrical accessories with the engine running to avoid discharging the vehicle battery. If you must use accessories while the engine is not running, do not use them for extended periods of time and do not use multiple electrical accessories at the same time.

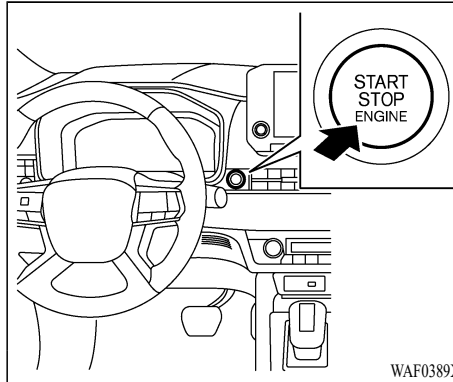

When the ignition switch is pushed without depressing the brake pedal, the ignition switch will illuminate.

Push the ignition switch center:

- once to change to ON.
- two times to change to OFF.

The ignition switch will automatically return to the LOCK position when any door is either opened or closed with the switch in the OFF position.

The ignition lock is designed so that the ignition switch position cannot be switched to OFF until the shift lever is moved to the P (Park) position.

When the ignition switch cannot be pushed toward the OFF position, proceed as follows:

1. Push the park button to shift to the P (Park) position.
2. Push the ignition switch. The ignition switch position will change to the ON position.
3. Push the ignition switch again to the OFF position.

The shift lever can be moved from the P (Park) position if the ignition switch is in the ON position and the brake pedal is depressed.

PUSH-BUTTON IGNITION SWITCH POSITIONS

LOCK (Normal parking position)

The ignition switch can only be locked at this position.

The ignition switch will lock when any door is opened or closed with the ignition switched off.

ON (Normal operating position)

The ignition system and the electrical accessory power activate at this position without the engine turned on.

The ON position has a battery saver feature that will place the ignition switch in the OFF position, if the vehicle is not running, after some time under the following conditions:

- all doors are closed.
- vehicle is in P (Park) position.

The battery saver feature will be cancelled if any of the following occur:

- any door is opened.
- shift lever is moved out of the P (Park) position.
- ignition switch changes position.

OFF position

The engine is turned off in this position.

Auto ACC position

With the vehicle in the P (Park) position, the F. A.S.T.-key with you and the ignition placed from ON to OFF, the radio can still be used for a period of time, or until the driver's door is opened. After a period of time, functions such as radio, navigation (if so equipped), and Bluetooth® Hands-Free Phone System may be restarted by turning on the audio system (see the separate Smartphone-link Display Audio (SDA) Owner's Manual), or by pushing the UNLOCK button on the F.A.S.T.-key for up to a total of 30 minutes.

EMERGENCY ENGINE SHUT OFF

To shut off the engine in an emergency situation while driving, perform the following procedure:

- Rapidly push the push-button ignition switch 3 consecutive times in less than 1.5 seconds, or
- Push and hold the push-button ignition switch for more than 2 seconds.

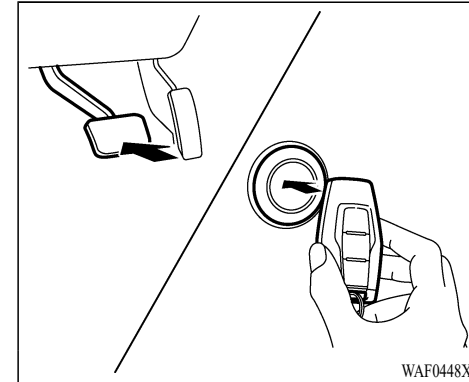

F.A.S.T.-KEY BATTERY DISCHARGE

If the battery of the F.A.S.T.-key is discharged, or environmental conditions interfere with the F.A.S.T.-key operation, start the engine according to the following procedure:

1. Push the park button to shift to the P (Park) position.
2. Firmly apply the foot brake.
3. Touch the ignition switch with the F.A.S.T.-key as illustrated. (A chime will sound.)
4. Push the ignition switch while depressing the brake pedal within 10 seconds after the chime sounds. The engine will start.

Starting and driving 5-15

BEFORE STARTING THE ENGINE STARTING THE ENGINE

After step 3 is performed, when the ignition switch is pushed without depressing the brake pedal, the ignition switch position will change to ACC.

NOTE:

- **When the ignition switch is pushed to the ON position or the engine is started by the above procedures, the “Key Battery Low” warning appears (on the multi-information display) even if the F.A.S.T.-key is inside the vehicle. This is not a malfunction. To turn off the warning, touch the ignition switch with the F.A.S.T.-key again.**
- **If the “Key Battery Low” warning appears (on the multi-information display), replace the battery as soon as possible. (See “F.A.S.T.-key battery replacement” (P.8-20).)**

- Make sure the area around the vehicle is clear.
- Check fluid levels such as engine oil, coolant, brake fluid, and window washer fluid as frequently as possible, or at least whenever you refuel.
- Check that all windows and lights are clean.
- Visually inspect tires for their appearance and condition. Also check tires for proper inflation.
- Lock all doors.
- Position seat and adjust head restraints.
- Adjust inside and door mirrors.
- Fasten seat belts and ask all passengers to do likewise.
- Check the operation of warning lights when the ignition switch is placed in the ON position. (See “Warning lights, indicator lights and audible reminders” (P.2-12).)

1. Apply the parking brake.
2. Confirm that the vehicle is in the P (Park) position.

The F.A.S.T.-key must be carried when operating the ignition switch.

3. Push the ignition switch to the ON position. Depress the brake pedal and push the ignition switch to start the engine.

To start the engine immediately, push and release the ignition switch while depressing the brake pedal with the ignition switch in any position.

- If the engine is very hard to start in extremely cold weather or when restarting, depress the accelerator pedal a little (approximately 1/3 to the floor) and while holding, crank the engine. Release the accelerator pedal when the engine starts.
- If the engine is very hard to start because it is flooded, depress the accelerator pedal all the way to the floor and hold it. Push the ignition switch to the ON position to start cranking the engine. After 5 or 6 seconds, stop cranking by pushing the ignition switch to OFF. After cranking the engine, release the accelerator pedal. Crank the engine **with your foot off the accelerator pedal** by depressing the brake pedal and pushing

the push-button ignition switch to start the engine. If the engine starts, but fails to run, repeat the above procedure.

CAUTION

Do not operate the starter for more than 15 seconds at a time. If the engine does not start, push the ignition switch to OFF and wait 10 seconds before cranking again, otherwise the starter could be damaged.

4. Warm-up

Allow the engine to idle for at least 30 seconds after starting. Do not race the engine while warming it up. Drive at moderate speed for a short distance first, especially in cold weather. In cold weather, keep the engine running for a minimum of 2 - 3 minutes before shutting it off. Starting and stopping the engine over a short period of time may make the vehicle more difficult to start.

When the engine is racing with no load and cold, the engine speed is limited to about 4,500 rpm.

- To stop the engine, push the park button to shift to the P (Park) position, and push the ignition switch to the OFF position.

NOTE:

Care should be taken to avoid situations that can lead to potential battery discharge and potential no-start conditions such as:

- Installation or extended use of electronic accessories that consume battery power when the engine is not running (Phone chargers, GPS, DVD players, etc.)**
- Vehicle is not driven regularly and/or only driven short distances.**

In these cases, the battery may need to be charged to maintain battery health.

DRIVING THE VEHICLE

CONTINUOUSLY VARIABLE TRANSMISSION (CVT)

The CVT in your vehicle is electronically controlled to produce maximum power and smooth operation.

The recommended operating procedures for this transmission are shown on the following pages. Follow these procedures for maximum vehicle performance and driving enjoyment.

Engine power may be automatically reduced to protect the CVT if the engine speed increases quickly when driving on slippery roads or while being tested on some dynamometers.

WARNING

- Do not depress the accelerator pedal while shifting from “P” (Park) or “N” (Neutral) to “R” (Reverse), “D” (Drive), or “M” (Manual shift mode). Always depress the brake pedal until shifting is completed. Failure to do so could cause you to lose control and have an accident.**
- Cold engine idle speed is high, so use caution when shifting into a forward or reverse gear before the engine has warmed up.**

- Do not downshift abruptly on slippery roads. This may cause a loss of control.
- Never shift to either the “P” (Park) or “R” (Reverse) position while the vehicle is moving forward and “P” (Park) or “D” (Drive) position while the vehicle is reversing. This could cause an accident or damage the transmission.
- Except in an emergency, do not shift to the “N” (Neutral) position while driving. Coasting with the transmission in the “N” (Neutral) position may cause serious damage to the transmission.

CAUTION

- To avoid possible damage to your vehicle, when stopping the vehicle on an uphill grade, do not hold the vehicle by depressing the accelerator pedal. The foot brake should be used for this purpose.
- Do not hang, attach or place any object, pouch or bag around the selector lever. The selector lever may unintentionally move resulting in an accident.

Starting the vehicle

1. After starting the engine, fully depress the foot brake pedal before attempting to move the shift lever out of the “P” (Park) position. **This CVT is designed so that the foot brake pedal must be depressed before shifting from “P” (Park) to any driving position while the ignition switch is in the “ON” position. The shift lever cannot be moved out of the “P” (Park) position and into any of the other positions if the ignition switch is placed in the “OFF” position.**
2. Keep the foot brake pedal depressed and move the shift lever into a driving position.
3. Release the parking brake, the foot brake pedal, and then gradually start the vehicle in motion.

CAUTION

- **DEPRESS THE FOOT BRAKE PEDAL -** Shifting the shift lever to “D” (Drive), “R” (Reverse) or “M” (Manual shift mode) without depressing the foot brake pedal causes the vehicle to move slowly when the engine is running. Make sure the foot brake pedal is depressed fully and the vehicle is stopped before shifting the shift lever.

- **MAKE SURE OF THE SHIFT LEVER POSITION -** Make sure the shift lever is in the desired position. “D” and manual shift mode are used to move forward and “R” to back up.
- **WARM UP THE ENGINE -** Due to the higher idle speeds when the engine is cold, extra caution must be exercised when shifting the shift lever into the driving position immediately after starting the engine.

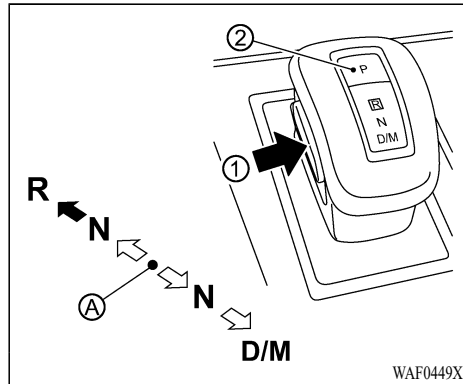

Ⓐ Home position (central position)

Shifting

To move the shift lever,

- ➡: Push the button ① to shift.
- ⇨: Shift without pushing the button ①.

Push the park button ② to shift to the P (Park) position.

After starting the engine, fully depress the brake pedal, push the shift lever button ① and move the shift lever from the P (Park) position ② to any of the desired shift positions.

Confirm that the vehicle is in the desired shift position by checking the shift indicator located

on the shift lever or on the multi-information display.

⚠ WARNING

Apply the electric parking brake if the shift lever is in any position while the engine is not running. Failure to do so could cause the vehicle to move unexpectedly or roll away and result in serious personal injury or property damage.

⚠ CAUTION

- Use the P (Park), R (Reverse) or D (Drive) position only when the vehicle is completely stopped.
- When switching to the desired shift position by operating the shift lever, check that the shift lever returns to the central position by releasing your hand from the lever. Holding the shift lever in a mid-way position may also damage the shift control system.
- Do not operate the shift lever while the accelerator pedal is depressed. This may cause a sudden start which could result in an accident.

- The following operations are not allowed because excessive force would be applied to the transmission and this may result in damage to the vehicle:

- Moving the shift lever to the R (Reverse) position when driving forward
- Moving the shift lever to the D (Drive) position when reversing

If these operations are attempted, a chime sounds and the vehicle shifts to the N (Neutral) position.

P (Park):

⚠ CAUTION

- To prevent transmission damage, use the P (Park) position only when the vehicle is completely stopped.
- Do not slide the shift lever while pushing the park button. This may damage the shift control system.

NOTE:

When the shift is in the P position, an operational noise may be heard from the lower part of the vehicle due to the evacuation operation of the vehicle. This is not a

malfunction.

Use this position when the vehicle is parked or starting the engine. Always make sure that the vehicle is completely stopped before pressing the park button  to engage the P (Park) position. For maximum safety, the brake pedal must be depressed before engaging the P (Park) position. Use this position together with the parking brake. When parking on a hill, first depress the brake pedal, apply the parking brake and then engage the P (Park) position. The parking lock should not be used as a brake when parking. In order to secure the vehicle, always apply the electric parking brake in addition to the parking lock.

In the event of a malfunction of the vehicle's electronics, the transmission may lock in the P (Park) position. Have the vehicle's electronics checked immediately. It is recommended that you visit an authorized Mitsubishi Motors dealer for this service.

The P (Park) position is automatically engaged if:

- You switch off the ignition switch.
- You unfasten the driver's seat belt and open the driver side door when the vehicle is stationary or driving at very low speed and the transmission is in the D (Drive) position or the R (Reverse) position.

R (Reverse):

To prevent transmission damage, use the R (Reverse) position only when the vehicle is completely stopped.

Use the R (Reverse) position to back up. Make sure the vehicle is completely stopped before selecting the R (Reverse) position. **The brake pedal must be depressed and the shift lever button pressed to move the shift lever from the idle position to R (Reverse). If the vehicle is placed in the R (Reverse) position while the vehicle is moving forward, the chime will sound and the vehicle will switch into the N (Neutral) position.**

N (Neutral):

Neither the forward nor reverse gear is engaged. The engine can be started in this position. You may shift to the N (Neutral) position and restart a stalled engine while the vehicle is moving.

You can select this position by holding the shift lever at this position for 0.5 seconds.

D (Drive):

Use this position for all normal forward driving. The CVT changes gears automatically. All

forward gears are available. **If the vehicle is placed in the D (Drive) position while the vehicle is reversing, the chime will sound and the vehicle will switch into the N (Neutral) position.**

Neutral hold mode function

This function enables you to turn off the engine with the vehicle in the N (Neutral) position. While this function is activated, the vehicle can be moved by pushing with hand (when car washing) even if the ignition switch is in the OFF position.



- Use this function on a level surface only. Failure to do so may cause the vehicle to move accidentally and could result in a collision or serious personal injury.
- Do not use this function for a purpose other than car washing.
- When the ignition switch is placed in the ON position after activated this function, depress the brake pedal to stop the vehicle because the shift position is in the N (Neutral) position.
- The shift lever cannot be moved from N (Neutral) position into R (Reverse) position. In order to shift to R (Reverse) position, the shift lever must shift to the

P (Park) position or the D (Drive) position once.

- **If this function is not activated regardless of proper operation, transmission may be a malfunction. It is recommended that you visit an authorized Mitsubishi Motors dealer for this service or a repair facility of your choice immediately.**

To activate the Neutral hold mode, perform the following operations.

1. Push the ignition switch to start the engine.
2. Release the electronic parking brake.
3. Depress and hold the brake pedal.
4. Push the P position switch.
5. Slide the shift lever to the N (Neutral) position, and hold it for 0.5 second until “N” appears in the multi-information display.
6. Slide the shift lever to the N (Neutral) position again, and hold it for 0.5 second, until a message “Neutral Hold Mode has been activated” appears in the multi-information display. (See “51. Neutral hold mode activated indicator” (P.2-39).)
7. Place the ignition switch in the OFF position. The engine will turn off with holding the N (Neutral) position.

To exit the Neutral hold mode, place the vehicle

in other than N (Neutral) position.

NOTE:

- **It is necessary to perform the steps 4 through 6 within approximately 5 seconds to prevent incorrect operation.**
- **When the ignition switch is placed in the OFF position while the shift lever is in the N (Neutral) position, a message will appear in the multi-information display. (See “50. Neutral hold mode guidance indicator” (P.2-39).)**
- **If the Neutral hold mode is unavailable, a message will appear in the multi-information display. (See “52. Neutral hold mode was not activated indicator” (P.2-39).) To activate the Neutral hold mode, wait for a while without shifting operation and then perform the operations again.**

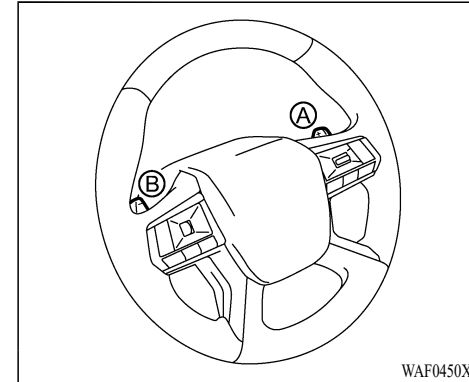

Steering wheel paddle shifter

When the shift lever is moved to the D (Drive) position again with the vehicle in the D (Drive) position while driving, the transmission enters the M (Manual) shift mode. Shift range can be selected manually.

When shifting up, pull the right-side paddle shifter (+) ④. The transmission shifts to the higher range.

When shifting down, pull the left-side paddle shifter (-) ⑤. The transmission shifts to the lower range.

When canceling the manual shift mode, move the shift lever to the D (Drive) position again.

The transmission returns to the normal driving mode.

When you pull the paddle shifter while in the D (Drive) position, the transmission will shift to the upper or lower range temporarily. The transmission will automatically return to the D (Drive) position after a short period of time. If you want to return to the D (Drive) position manually, pull and hold the right-side paddle shifter (+)  for approximately 1.5 seconds.

In the manual shift mode, the shift range is displayed in the multi-information display.

Shift ranges up or down one by one (1M to 8M).

8^M (8th):

Use this position for all normal forward driving at highway speeds.

7^M (7th), 6^M (6th) and 5^M (5th):

Use these positions when driving up long slopes, or for engine braking when driving down long slopes.

4^M (4th), 3^M (3rd) and 2^M (2nd):

Use these positions for hill climbing or engine braking on downhill grades.

1^M (1st):

Use this position when climbing steep hills slowly or driving slowly through deep snow, or for maximum engine braking on steep downhill

grades.

- Remember not to drive at high speeds for extended periods of time in lower than 8th gear. This reduces fuel economy.
- Pulling the same paddle shifter twice will shift the ranges in succession. However, if this motion is rapidly done, the second shifting may not be completed properly.
- **In the manual shift mode, the transmission may not shift to the selected gear. This helps maintain driving performance and reduces the chance of vehicle damage or loss of control.**
- **When this situation occurs, the Continuously Variable Transmission (CVT) position indicator will blink and the chime will sound.**
- **In the manual shift mode, the transmission may shift up automatically to a higher range than selected if the engine speed is too high. When the vehicle speed decreases, the transmission automatically shifts down and shifts to 1st gear before the vehicle comes to a stop.**
- CVT operation is limited to automatic drive mode when CVT fluid temperature is extremely low even if manual shift mode is selected. This is not a malfunction. When CVT fluid warms up, manual shift mode can be selected.

- When the CVT fluid temperature is high, the shift range may upshift in lower rpm than usual. This is not a malfunction.

Accelerator downshift - in D (Drive) position -

For passing or climbing hills, depress the accelerator pedal to the floor. This shifts the transmission down into a lower gear, depending on the vehicle speed.

High fluid temperature protection mode

This transmission has a high fluid temperature protection mode. If the fluid temperature becomes too high, (for example, when climbing steep grades in high temperatures with heavy loads), engine power and, under some conditions, vehicle speed will be decreased automatically to reduce the chance of transmission damage. Vehicle speed can be controlled with the accelerator pedal, but the engine and vehicle speed may be limited.

Fail-safe

When the fail-safe operation occurs, the Continuously Variable Transmission will not be shifted into the selected driving position.

If the vehicle is driven under extreme conditions, such as excessive wheel spinning

5-22 Starting and driving

and subsequent hard braking, the fail-safe system may be activated. The Malfunction Indicator Light (MIL) may come on to indicate the fail-safe mode is activated. For additional information, refer to “Malfunction Indicator Light (MIL)” (P.2-18). This will occur even if all electrical circuits are functioning properly. In this case, place the ignition switch in the “OFF” position and wait for 10 seconds. Then place the ignition switch back in the “ON” position. The vehicle should return to its normal operating condition. (The MIL may be illuminated even when the vehicle has returned to its normal operating condition.) If it does not return to its normal operating condition, have the transmission checked and repaired, if necessary, by an authorized Mitsubishi Motors dealer or a repair facility of your choice immediately.

WARNING

When the high fluid temperature protection mode or fail-safe operation occurs, vehicle speed may be gradually reduced. The reduced speed may be lower than other traffic, which could increase the chance of a collision. Be especially careful when driving. If necessary, pull to the side of the road at a safe place and allow the transmission to return to normal

operation, or have it repaired if necessary.

PARKING BRAKE

WARNING

- Never drive the vehicle with the parking brake applied. The brake will overheat and fail to operate and will lead to an accident.
- Never release the parking brake from outside the vehicle. If the vehicle moves, it will be impossible to push the foot brake pedal and will lead to an accident.
- Never use the shift lever in place of the parking brake. When parking, be sure the parking brake is fully applied.
- To help avoid risk of injury or death through unintended operation of the vehicle and/or its systems, do not leave children, people who require the assistance of others or pets unattended in your vehicle. Additionally, the temperature inside a closed vehicle on a warm day can quickly become high enough to cause a significant risk of injury or death to people and pets.

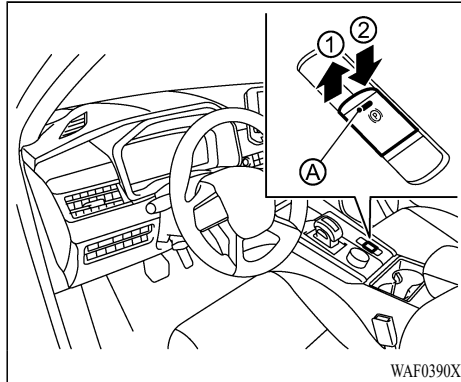

The electric parking brake can be released automatically or by operating the parking brake switch.

AUTOMATIC OPERATION

The electric parking brake is automatically released as soon as the vehicle starts while the accelerator pedal is depressed under the following conditions.

- while the engine is running.
- when the shift lever is in the D (Drive) or R (Reverse) position.
- when the driver's door is closed.

5-24 Starting and driving

WARNING

Before leaving the vehicle, move the shift lever to the P (Park) position and check that the electric parking brake warning light is illuminated to confirm that the electric parking brake is applied. The electric parking brake warning light will remain on for a period of time after the driver's door is locked.

CAUTION

- When parking in an area where the outside temperature is below 32°F (0°C), do not apply the parking brake to prevent it from freezing.

For safe parking, place the shift lever in the P (Park) position and securely block the wheels.

NOTE:

- If a malfunction occurs in the electric parking brake system (for example, due to battery discharge), it is recommended to contact an authorized Mitsubishi Motors dealer.
- If the shift lever is moved to the P (Park) position when the brake force is maintained by the Brake Auto Hold function,

the electric parking brake will apply automatically.

- If the driver's seat belt is unfastened when the brake force is maintained by the Brake Auto Hold function, the electric parking brake will apply automatically.
- If the ignition switch is placed in the OFF position when the brake force is maintained by the Brake Auto Hold function, the electric parking brake will apply automatically.
- Before driving, make sure that the electric parking brake warning light (yellow) is OFF.

MANUAL OPERATION

To apply: When the vehicle is stopped, pull the switch up ①. (The electric parking brake will apply even if the ignition switch is placed in the "OFF" position.) The indicator light ④ and the electric parking brake warning light (red) will illuminate.

To release: With the ignition switch in the ON position, depress the brake pedal and push the switch down ②. The indicator light ④ and the electric parking brake warning light (red) will turn off.

Before driving, check that the electric parking brake warning light (red) goes out. For addi-

tional information, see “Warning lights, indicator lights and audible reminders” (P.2-12).

NOTE:

- A chime will sound if the vehicle is driven without releasing the parking brake. See “Audible reminders” (P.2-20).
- While the electric parking brake is applied or released, an operating sound is heard from the lower side of the rear seat. This is normal and does not indicate a malfunction.
- When the electric parking brake is frequently applied and released in a short period of time, the electric parking brake warning light (yellow) may blink and the parking brake may not operate in order to prevent the parking brake system from overheating. If this occurs, operate the electric parking brake switch again after waiting approximately 1 minute.
- If the electric parking brake must be applied while driving in an emergency, pull up and hold the parking brake switch. When you release the parking brake switch, the parking brake will be released.
- While pulling up the electric parking brake switch during driving, the parking brake is applied and a chime sounds. The electric parking brake warning light in

the meter and in the parking brake switch illuminate. This does not indicate a malfunction. The electric parking brake warning light in the meter and in the parking brake switch turn off when the parking brake is released.

- When pulling the electric parking brake switch up with the ignition switch in the OFF or ACC position, the parking brake switch indicator light will continue to illuminate for a short period of time.

Depending on the weight of the vehicle and trailer and the steepness of the slope, there may be a tendency for the vehicle to move backwards when starting from a standstill. When this occurs, you can use the parking brake switch in the same way as a conventional lever type parking brake.

Before starting on sloping roads when towing a trailer, be sure to read the following to prevent the vehicle from moving backward unintentionally.

- Push the switch down to release the parking brake switch as soon as the engine is delivering enough torque to the wheels.

BRAKE AUTO HOLD

The Brake Auto Hold function maintains the braking force without the driver having to depress the brake pedal when the vehicle is stopped at a traffic light or intersection. As soon as the driver depresses the accelerator pedal again, the Brake Auto Hold function is deactivated and the braking force is released. The operating status of the Brake Auto Hold can be displayed on the multi-information display.



WARNING

- The Brake Auto Hold function is not designed to hold the vehicle on a steep hill or slippery road. Never use the Brake Auto Hold when the vehicle is stopped on a steep hill or slippery road. Failure to do so may cause the vehicle to move.
- When the Brake Auto Hold function is activated but fails to maintain the vehicle at a standstill, depress the brake pedal to stop the vehicle. If the vehicle unexpectedly moves due to outside conditions, the chime may sound and Brake Auto Hold warning may illuminate in the multi-information display.
- Be sure to deactivate the Brake Auto Hold function when using a car wash or towing your vehicle.

- Make sure to push the park button to shift to the P (Park) position and apply the parking brake when parking your vehicle, riding on or off the vehicle, or loading luggage. Failure to do so could cause the vehicle to move or roll away unexpectedly and result in serious personal injury or property damage.
- If any of the following conditions occur, the Brake Auto Hold function may not function. Have the system checked promptly. It is recommended that you visit an authorized Mitsubishi Motors dealer for this service. Failure to operate the vehicle in accordance with these conditions could cause the vehicle to move or roll away unexpectedly and result in serious personal injury or property damage.
 - A warning message appears in the multi-information display.
 - The indicator light on the Brake Auto Hold switch does not illuminate when the switch is pushed.
- The Brake Auto Hold function will not be activated if the Active stability control (ASC) warning light, electric parking brake warning light or master warning light illuminate and the Chassis Control System Error message appears in the multi-information display.

- To maintain the braking force to keep the vehicle to a standstill, a noise may be heard. This is not a malfunction.

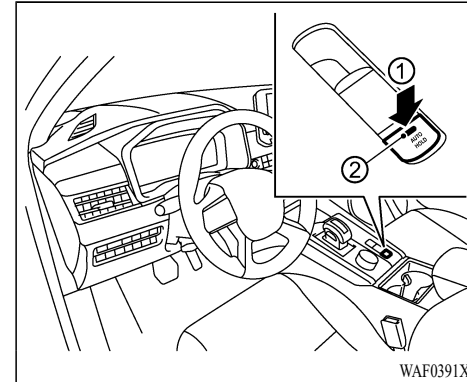

HOW TO ACTIVATE/DEACTIVATE THE BRAKE AUTO HOLD FUNCTION

How to activate the Brake Auto Hold function

1. With the ignition switch in the ON position, push the Brake Auto Hold switch ①. The indicator light on the Brake Auto Hold switch ② illuminates.
2. When the Brake Auto Hold function goes into standby, the Brake Auto Hold indicator light (white) illuminates.

To use the Brake Auto Hold function, the

following conditions need to be met.

- The driver's seat belt is fastened.
- The electric parking brake is released.
- The vehicle is not in the P (Park) position.
- The vehicle is not parked on a steep hill.

NOTE:

The Brake Auto Hold function resets to OFF every time the ignition switch is switched from the OFF position to the ON position.

How to deactivate the Brake Auto Hold function

While the Brake Auto Hold function is activated, push the Brake Auto Hold switch to turn off the Brake Auto Hold indicator light and deactivate the Brake Auto Hold function. To deactivate the Brake Auto Hold function while the brake force has been maintained by the Brake Auto Hold function, depress the brake pedal and push the Brake Auto Hold switch.

 **WARNING**

Make sure to firmly depress and hold the brake pedal when turning off the Brake Auto Hold function while the brake force is applied. When the Brake Auto Hold function is deactivated, the brake force will be released. This could cause the vehicle to move or roll away unexpectedly.

Failure to prevent the vehicle from rolling may result in serious personal injury or property damage.

HOW TO USE THE BRAKE AUTO HOLD FUNCTION

For additional information on using the Brake Auto Hold function, refer to the instructions outlined in this section.

To maintain braking force automatically

With the Brake Auto Hold function activated and the Brake Auto Hold indicator light (white) illuminated on the meter, depress the braking pedal to stop the vehicle. The brake pressure that driver depressed will be maintained. While the brake hold is maintained, the Brake Auto Hold indicator light (green) illuminates on the meter.

To start the vehicle from a standstill

With the vehicle not in the P (Park) or the shift lever not in the N (Neutral) position, depress the accelerator pedal while the brake force is maintained. The brake force will automatically be released to restart the vehicle. The Brake Auto Hold indicator light (white) on the meter illuminates and the Brake Auto Hold returns to standby.

Parking

When the park button is pushed to shift to the P (Park) position with the brake force maintained by the Brake Auto Hold function, the parking brake will automatically be applied and the brake force of the Brake Auto Hold will be released. The Brake Auto Hold indicator light turns off. When the parking brake is applied with the brake force maintained by the Brake Auto Hold function, the brake force of the Brake Auto Hold will be released. The Brake Auto Hold indicator light turns off.

NOTE:

- **Under the following conditions, the parking brake will automatically be applied and the brake force of the Brake Auto Hold will be released:**
 - **The braking force is applied by the Brake Auto Hold function for 3 minutes or longer.**
 - **The driver's seat belt is unfastened.**
 - **The ignition switch is placed in the OFF position.**
 - **If a malfunction occurs in the Brake Auto Hold function.**
- **When the vehicle stops, but the brake force is not maintained, depress the brake pedal firmly until the Brake Auto Hold indicator light (green) illuminates.**

DRIVE MODE SELECTOR

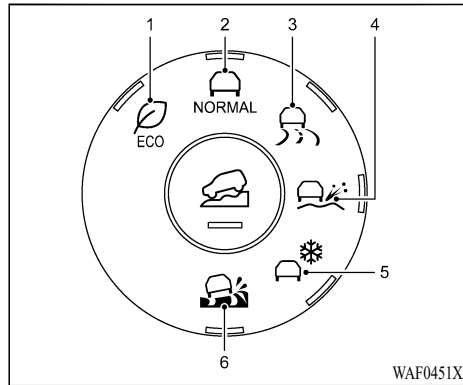

Drive Mode Selector (Example)

1. ECO mode
2. NORMAL mode
3. TARMAC mode
4. GRAVEL mode
5. SNOW mode
6. MUD mode (AWC model)

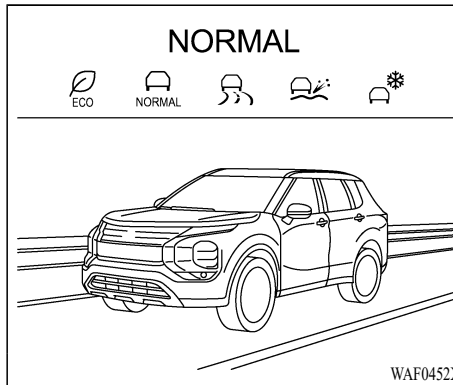

Display (Example)

Drive mode Selector is able to select characteristics of an integrated vehicle dynamics control system that helps to enhance driving performance, and vehicle stability over a wide range of the driving style of driving condition through integrated management of the engine, the transmission, the EPS, the AWC (if so equipped), AYC (Active Yaw Control), the ABS and the ASC .

Select a drive mode from following types to suit the driving style or the driving condition:

NORMAL, GRAVEL, ECO, SNOW, TARMAC, MUD (for AWC model only).

The current mode is displayed in the multi-information display.

To change the mode, turn the Drive Mode Selector right or left. The mode list will appear in the multi-information display and you can select a mode.

NOTE:

- The mode list will be turned off in approximately 5 seconds after a mode is selected.
- The drive mode will be automatically turned to the NORMAL mode when the ignition switch is turned to off and on again.

If the driving mode cannot be switched using the Drive Mode Selector when the ignition switch is in the ON position, have the system checked. It is recommended you visit an authorized Mitsubishi Motors dealer for this service.

WARNING

Do not stare at the Drive Mode Selector or the display while driving so that full attention may be given to vehicle operation.

NORMAL MODE

This mode offers well-balanced driving performance with efficiency for SUV in various road conditions.

ECO MODE

This mode supports ecological and economical driving by optimized powertrain characteristic.

NOTE:

Selecting the ECO mode will not necessarily improve fuel economy as many driving factors influence its effectiveness.

Operation

Select the ECO mode using the Drive Mode Selector. The ECO drive indicator light on the instrument panel illuminates.

When the accelerator pedal is depressed within the range of economy drive, the ECO drive indicator light illuminates in green. When the accelerator pedal is depressed above the range of economy drive, the ECO drive indicator light turns off.

The ECO drive indicator light will not illuminate in the following cases:

- When the shift lever is in the R (Reverse), P (Park) or N (Neutral) position.
- When the vehicle speed is below 6 MPH (10 km/h) or over 75 MPH (120 km/h).

- When the cruise control (if so equipped) or the Adaptive Cruise Control System (ACC) system (if so equipped) is operated.

Tire Pres ECO advice

The “Tire Pres ECO advice” is a function to show an ECO advice information in the multi-information display when low tire pressure is detected. To activate or deactivate this function, see “ECO Mode Setting” (P.2-25).

When the setting is ON, the ECO Drive Report display shows "See Tire Pressures". You can switch the display to the Tire Pressures display by pushing the ◀ ▶ button on the steering wheel.

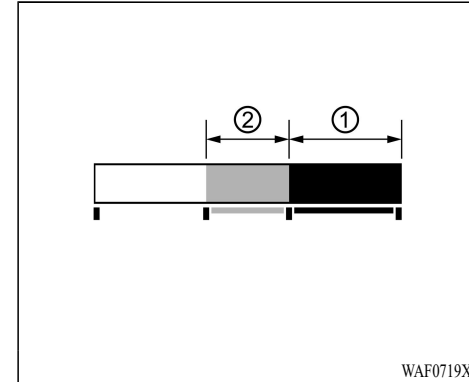

ECO Pedal Guide function

The ECO Pedal Guide display can be selected in the multi-information display in the ECO mode. Use the ECO Pedal Guide function for improving fuel economy.

When the ECO Pedal Guide bar is in the green range ①, it indicates that the vehicle is being driven within range of the super economy drive.

When the ECO Pedal Guide bar is in the light green range ②, it indicates that the vehicle is being driven within range of the economy drive.

If the ECO Pedal Guide bar is out of the green range (① and ②), it indicates that the accelerator pedal is depressed over the range of economy

drive.

The ECO Pedal Guide bar is not displayed when:

- The vehicle speed is less than approximately 2 MPH (4 km/h).
- The shift lever is in the P (Park), N (Neutral) or R (Reverse) position.

TARMAC MODE

This mode offers the pleasure of driving with agile dynamics on dry paved road, such as responsive and powerful acceleration, responsive and linear steering feel, stability and traceability on cornering.

GRAVEL MODE

This mode is for driving on rough road surfaces such as flat unpaved roads or wet paved roads and improves straightability on rough road and powerful launching acceleration.

NOTE:

When the GRAVEL mode is selected, the Adaptive Cruise Control (ACC) and MI-PILOT Assist functions cannot be activated.

SNOW MODE

This mode is for driving on slippery road surfaces, such as snow-covered roads and offers good initial steering response and high cornering stability on a slippery road.

NOTE:

When the SNOW mode is selected, the Adaptive Cruise Control (ACC) and MI-PILOT Assist functions cannot be activated.

MUD MODE (AWC model)

This mode is for driving on slippery road where maximum traction is required, such as muddy roads and deep snow roads and improves traction performance.

NOTE:

When the MUD mode is selected, the Adaptive Cruise Control (ACC) and MI-PILOT Assist functions cannot be activated.

TRAFFIC SIGN RECOGNITION (TSR) (if so equipped)

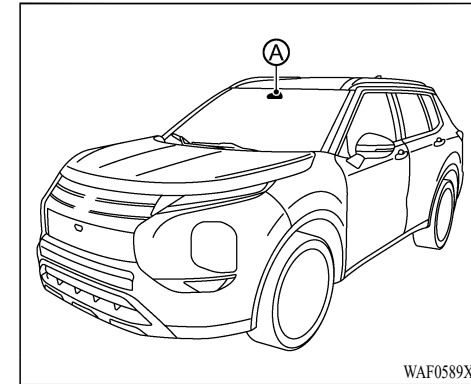

The Traffic Sign Recognition (TSR) system provides the driver with information about the most recently detected speed limit. The system captures the road sign information with the multi-sensing front camera unit **A** located on the windshield in front of the inside rearview mirror and displays the detected signs in the multi-information display. For vehicles equipped with Navigation System, the speed limit displayed is based on a combination of Navigation System data and live camera recognition. TSR information is shown in the multi-information display and in the Head-Up Display (if so equipped). (See “Head-Up Display (HUD)” (P.2-43).)

WARNING

The TSR system is only intended to be a support device to help provide the driver with information. It is not a replacement for the driver's attention to traffic conditions or responsibility to drive safely. It cannot prevent accidents due to carelessness. Depending on the situation, the system may not be able to recognise traffic signs or the displayed traffic sign information may be different from the actual information. It is the driver's responsibility to stay alert and drive safely at all times.

SYSTEM OPERATION

The Traffic Sign Recognition (TSR) system displays the following types of road sign (example):

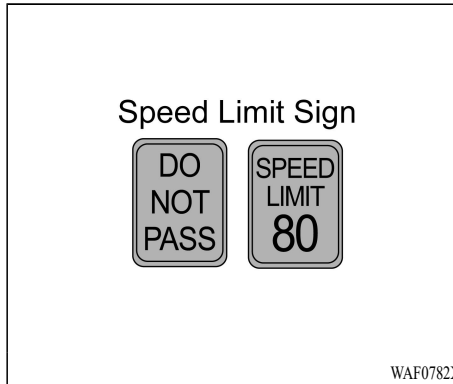

Example

- **“DO NOT PASS”**
 - indicates that the vehicle is in a no-overtaking zone.
- **“SPEED LIMIT”**
 - indicates the latest detected speed limit.

CAUTION

- The TSR system is intended as an aid to careful driving. It is the driver's responsibility to stay alert, drive safely, and observe all road regulations that currently apply, including looking out for road signs.

- The TSR system may not function properly under the following conditions:
 - When the road sign is not clearly visible, for example, due to damage or weather conditions.
 - When rain, snow or dirt adheres to the windshield in front of the multi-sensing front camera unit.
 - When the headlights are not bright due to dirt on the lens or if the aiming is not adjusted properly.
 - When strong light enters the camera unit. (For example, the light directly shines on the front of the vehicle at sunrise or sunset.)
 - When a sudden change in brightness occurs. (For example, when the vehicle enters or exits a tunnel or under a bridge.)
 - In areas not covered by the navigation system.
 - If there are deviations in relation to the navigation, for example due to changes in the road routing.
 - When overtaking buses or trucks with speed stickers.

— When the data from the navigation system is not up-to-date or is unavailable.

- The TSR system may display a traffic sign, though there is no traffic sign in front of the vehicle. It may display a different speed limit from that for a passenger vehicle. (The maximum speed limit sign may show a higher or lower number than the actual maximum speed, for example, when detecting a speed limit sign for truck, advisory sign, different speed limit sign between daytime and nighttime, or speed limit sign written in different unit near the border, etc.)
- Depending on the condition, the TSR may display traffic signs that different from that in the Navigation - turn by turn display in the Multi-information display, and that in the navigation system display.

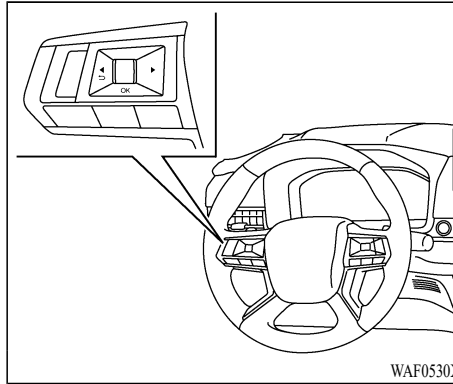

HOW TO ENABLE/DISABLE THE TSR SYSTEM

Perform the following steps to enable or disable the TSR system:

1. Press the ◀ ▶ button until “Settings” appears in the multi-information display and then press the scroll dial. Rotate the scroll dial to select “Driver Assistance”. Then press the scroll dial.
2. Select “Traffic Sign” and press the scroll dial to turn the system on or off.

SYSTEM TEMPORARILY UNAVAILABLE

If the vehicle is parked in direct sunlight under high temperature conditions (over approximately 104°F (40°C) and then started, the TSR system may be deactivated automatically. The “Unavailable High Cabin Temperature” warning message will appear in the multi-information display.

Action to take:

When the interior temperature is reduced, the TSR system will resume operating automatically.

SYSTEM MALFUNCTION

If the TSR system malfunctions it will be turned off automatically and the TSR “Malfunction” warning message will appear in the multi-information display.

Action to take

If the TSR “Malfunction” warning message appears, pull off the road at a safe location and stop the vehicle. Turn the engine off and restart the engine. If the TSR “Malfunction” message continues to appear, have the system checked by an authorized Mitsubishi Motors dealer.

LANE DEPARTURE WARNING (LDW)

SYSTEM MAINTENANCE

The TSR system uses the same multi-sensing front camera unit that is used by the Lane Departure Warning (LDW) system, located in front of the interior rearview mirror. For maintenance of the camera, see “System maintenance” (P.5-37).

WARNING

Failure to follow the warnings and instructions for proper use of the LDW system could result in serious injury or death.

- **This system is only a warning device to inform the driver of a potential unintended lane departure. It will not steer the vehicle or prevent loss of control. It is the driver’s responsibility to stay alert, drive safely, keep the vehicle in the traveling lane, and be in control of the vehicle at all times.**

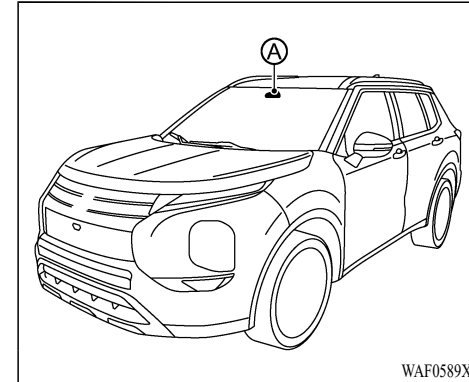

The LDW system will operate when the vehicle is driven at speeds of approximately 37 MPH (60 km/h) and above, and the lane markings are clearly visible on the road.

The LDW system monitors the lane markers on the traveling lane using the camera unit  located above the inside mirror.

The LDW system warns the driver that the vehicle is beginning to leave the driving lane with an indicator and a steering wheel vibration. (See “LDW system operation” (P.5-34).)

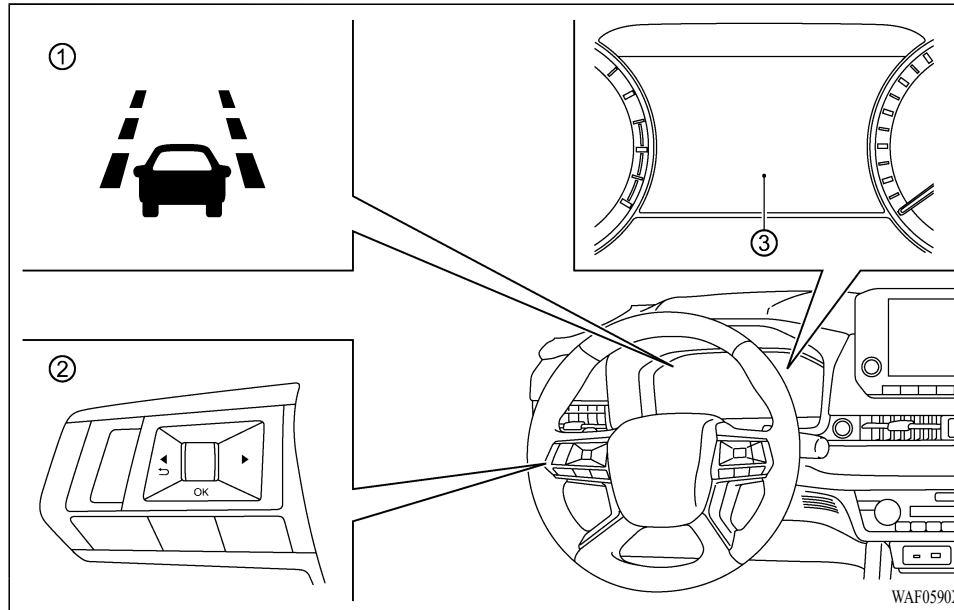

- ① LDW indicator (on the multi-information display)
- ② Steering wheel remote control switches (left side)
- ③ Multi-information display

LDW SYSTEM OPERATION

The LDW system provides a lane departure warning function when the vehicle is driven at speeds of approximately 37 MPH (60 km/h) and above and the lane markings are clear. When the vehicle approaches either the left or the right side of the traveling lane, the steering wheel

will vibrate and the LDW indicator ① on the multi-information display ③ will blink to alert the driver.

The warning function will stop when the vehicle returns inside of the lane markers.

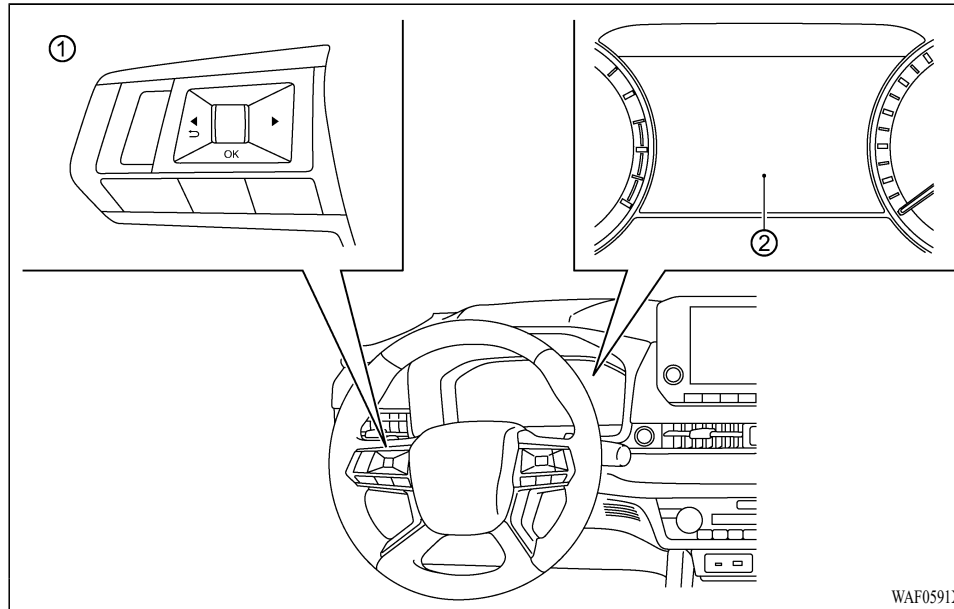

- ① Steering wheel remote control switches (left side)
 ② Multi-information display

HOW TO ENABLE/DISABLE THE LDW SYSTEM

Perform the following steps to enable or disable the LDW system.

1. Push the ◀ ▶ button until “Settings” appears in the multi-information display ②

and then push the scroll dial. Use the scroll dial to select “Driver Assistance”. Then push the scroll dial.

2. Select “Lane” and push the scroll dial.
3. Select “Warning (LDW)” and push the scroll dial.

NOTE:

If you disable the LDW system, the system will remain disabled the next time you start the vehicle’s engine.

LDW SYSTEM LIMITATIONS

WARNING

Listed below are the system limitations for the LDW system. Failure to follow the warnings and instructions for proper use of the LDW system could result in serious injury or death.

- The system will not operate at speeds below approximately 37 MPH (60 km/h) or if it cannot detect lane markers.
- Do not use the LDW system under the following conditions as it may not function properly:
 - During bad weather (rain, fog, snow, etc.).
 - When driving on slippery roads, such as on ice or snow.

- When driving on winding or uneven roads.
- When there is a lane closure due to road repairs.
- When driving in a makeshift or temporary lane.
- When driving on roads where the lane width is too narrow.
- When driving without normal tire conditions (for example, tire wear, low tire pressure, installation of tire chains, non-standard wheels).
- When the vehicle is equipped with non-original brake parts or suspension parts.
- When towing a trailer or other vehicle.
- The system may not function properly under the following conditions:
 - On roads where there are multiple parallel lane markers; lane markers that are faded or not painted clearly; yellow painted lane markers; non-standard lane markers; or lane markers covered with water, dirt, snow, etc.

- On roads where discontinued lane markers are still detectable.
- On roads where there are sharp curves.
- On roads where there are sharply contrasting objects, such as shadows, snow, water, wheel ruts, seams or lines remaining after road repairs. (The LDW system could detect these items as lane markers.)
- On roads where the traveling lane merges or separates.
- When the vehicle's traveling direction does not align with the lane marker.
- When traveling close to the vehicle in front of you, which obstructs the lane camera unit detection range.
- When rain, snow, dirt or object adheres to the windshield in front of the lane camera unit.
- When the headlights are not bright due to dirt on the lens or if the aiming is not adjusted properly.

- When strong light enters the lane camera unit. (For example, the light directly shines on the front of the vehicle at sunrise or sunset.)
- When a sudden change in brightness occurs. (For example, when the vehicle enters or exits a tunnel or under a bridge.)

SYSTEM TEMPORARILY UNAVAILABLE

Condition A:

If the vehicle is parked in direct sunlight under high temperature conditions (over approximately 104°F (40°C)) and then started, the LDW system may be deactivated automatically, the LDW indicator will flash and the following message will appear in the multi-information display. - “Unavailable: High Cabin Temperature”

When the interior temperature is reduced, the LDW system will resume operating automatically and the LDW indicator will stop flashing.

Condition B:

The warning function of the LDW system is not designed to work under the following conditions:

- When you operate the lane change signal and change traveling lanes in the direction of the signal. (The LDW system will become operable again approximately 2 seconds after the lane change signal is turned off.)
- When the vehicle speed lowers to less than approximately 37 MPH (60 km/h).

Action to take:

After the above conditions have finished and the necessary operating conditions are satisfied, the LDW system will resume.

SYSTEM MALFUNCTION

If the LDW system malfunctions, it will cancel automatically and “Not Available System Malfunction” will appear in the multi-information display. If “Not Available System Malfunction” appears in the multi-information display, pull off the road to a safe location and stop the vehicle. Place the ignition switch in the OFF position and restart the engine. If “Malfunction” continues to appear in the multi-information display, have the system checked. It is recommended that you visit an authorized Mitsubishi Motors dealer for this service.

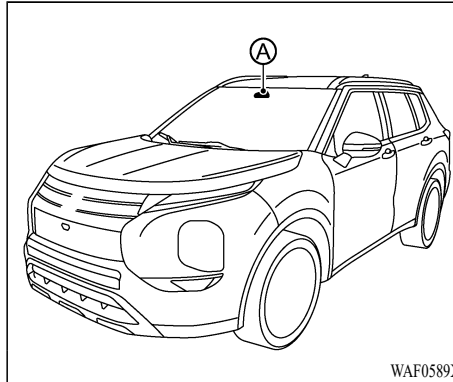

SYSTEM MAINTENANCE

The lane camera unit ① for the LDW system is located above the inside mirror.

To keep the proper operation of the LDW system and prevent a system malfunction, be sure to observe the following:

- Always keep the windshield clean.
- Do not attach a sticker (including transparent material) or install an accessory near the camera unit.
- Do not place reflective materials, such as white paper or a mirror, on the instrument panel. The reflection of sunlight may adversely affect the camera unit’s capability of detecting the lane markers.

- Do not strike or damage the areas around the camera unit. Do not touch the camera lens or remove the screw located on the camera unit. If the camera unit is damaged due to an accident, it is recommended that you visit an authorized Mitsubishi Motors dealer.

LANE DEPARTURE PREVENTION (LDP) (if so equipped)

WARNING

Failure to follow the warnings and instructions for proper use of the LDP system could result in serious injury or death.

- The LDP system will not steer the vehicle or prevent loss of control. It is the driver's responsibility to stay alert, drive safely, keep the vehicle in the traveling lane, and be in control of the vehicle at all times.
- The LDP system is primarily intended for use on well-developed freeways or highways. It may not detect the lane markers in certain road, weather, or driving conditions.

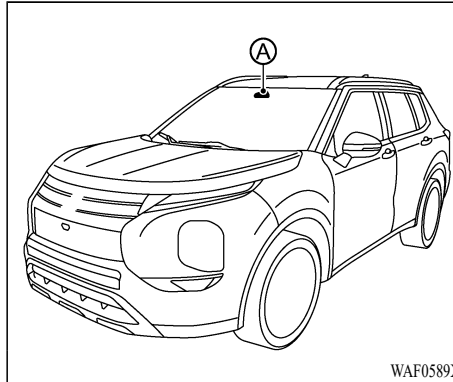

the traveling lane using the camera unit  located above the inside mirror.

The LDP system must be turned on with the MI-PILOT Assist switch on the steering wheel, every time the ignition is placed in the ON position.

The LDP system will operate when the vehicle is driven at speeds of approximately 37 MPH (60 km/h) and above, and only when the lane markings are clearly visible on the road. The LDP system warns the driver when the vehicle has left the center of the traveling lane with an indicator and steering wheel vibration. The system helps assist the driver to return the vehicle to the center of the traveling lane by applying the brakes to the left or right wheels individually (for a short period of time).

The LDP system monitors the lane markers on

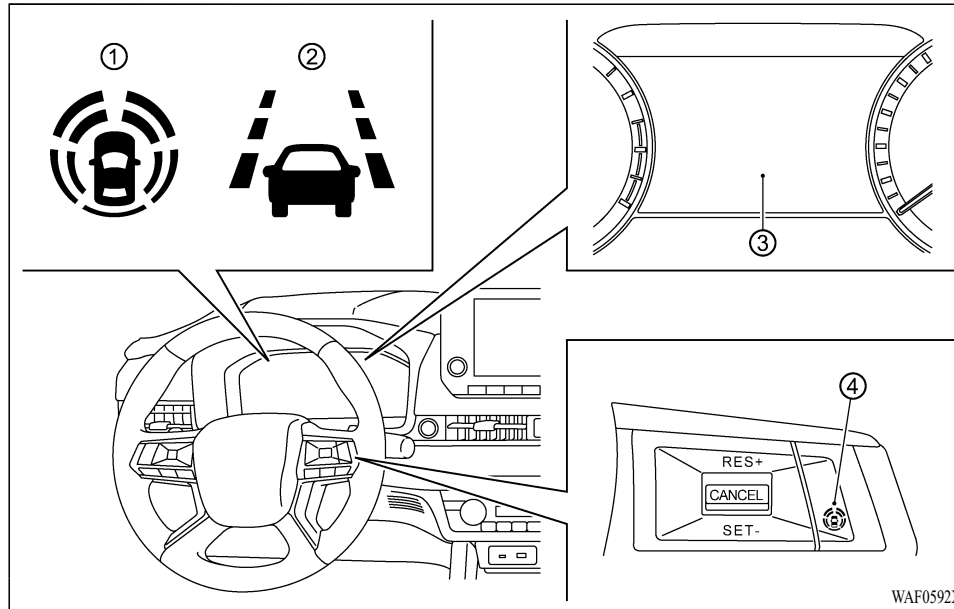

- ① LDP ON indicator (on the multi-information display)
- ② LDP indicator (on the multi-information display)
- ③ Multi-information display
- ④ MI-PILOT Assist switch

LDP SYSTEM OPERATION

The LDP system operates above approximately 37 MPH (60 km/h) and when the lane markings are clear. When the vehicle approaches either the left or the right side of the traveling lane, the steering wheel will vibrate and the LDP indicator (orange) ② on the multi-information

display will blink to alert the driver. Then, the LDP system will automatically apply the brakes for a short period of time to help assist the driver to return the vehicle to the center of the traveling lane.

To turn on the LDP system, push the MI-PILOT Assist switch ④ on the steering wheel after starting the engine. The LDP ON indicator ① on the multi-information display ③ will illuminate. Push the MI-PILOT Assist switch again to turn off the LDP system. The LDP ON indicator will turn off.

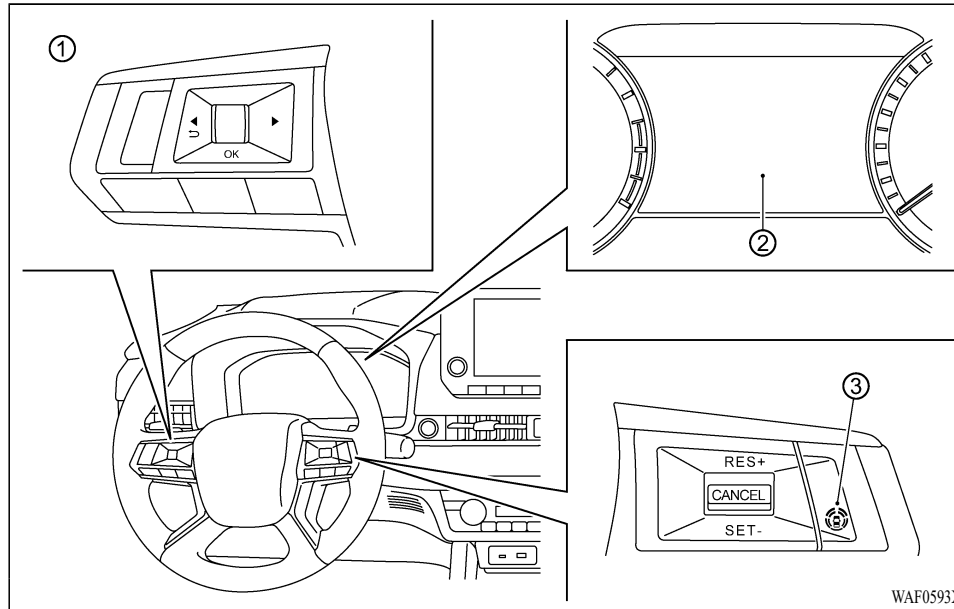

- ① Steering wheel remote control switches (left side)
- ② Multi-information display
- ③ MI-PILOT Assist switch

HOW TO ENABLE/DISABLE THE LDP SYSTEM

Perform the following steps to enable or disable the LDP system.

1. Push the ◀ ▶ button until “Settings” appears in the multi-information display ②

- and then push the scroll dial. Use the scroll dial to select “Driver Assistance.” Then push the scroll dial.
2. Select “Lane” and push the scroll dial.
3. Select “Prevention (LDP)” and push the scroll dial.
4. Push the MI-PILOT Assist switch ③ to turn the system on or off.

NOTE:

Turning on the MI-PILOT Assist system (if so equipped) will turn on the LDP and ABSA system at the same time. If the LDP system is disabled in the settings menu, the LDP will automatically be turned on when the Lane Keep Assist (LKA) system is active. (See “MI-PILOT Assist” (P.5-90).)

LDP SYSTEM LIMITATIONS

! WARNING

Listed below are the system limitations for the LDP system. Failure to follow the warnings and instructions for proper use of the LDP system could result in serious injury or death.

- The LDP system may activate if you change lanes without first activating your turn signal or, for example, if a construction zone directs traffic to cross an existing lane marker. If this occurs you may need to

apply corrective steering to complete your lane change.

- Because the LDP may not activate under the road, weather, and lane marker conditions described in this section, it may not activate every time your vehicle begins to leave its lane and you will need to apply corrective steering.
- The LDP system will not operate at speeds below approximately 37 MPH (60 km/h) or if it cannot detect lane markers.
- When the LDP system is operating, avoid excessive or sudden steering maneuvers. Otherwise, you could lose control of the vehicle.
- Do not use the LDP system under the following conditions as it may not function properly:
 - During bad weather (rain, fog, snow, etc.).
 - When driving on slippery roads, such as on ice or snow.
 - When driving on winding or uneven roads.
 - When there is a lane closure due to road repairs.
 - When driving in a makeshift or temporary lane.

- When driving on roads where the lane width is too narrow.
- When driving without normal tire conditions (for example, tire wear, low tire pressure, installation of spare tire, tire chains, non-standard wheels).
- When the vehicle is equipped with non-original brake parts or suspension parts.
- When towing a trailer or other vehicle.
- On roads where there are multiple parallel lane markers; lane markers that are faded or not painted clearly; yellow painted lane markers; non-standard lane markers; or lane markers covered with water, dirt, snow, etc.
- On roads where discontinued lane markers are still detectable.
- On roads where there are sharp curves.
- On roads where there are sharply contrasting objects, such as shadows, snow, water, wheel ruts, seams or lines remaining after road repairs. (The LDP system

could detect these items as lane markers.)

- On roads where the traveling lane merges or separates.
- When the vehicle's traveling direction does not align with the lane marker.
- When traveling close to the vehicle in front of you, which obstructs the lane camera unit detection range.
- When rain, snow or dirt adheres to the windshield in front of the lane camera unit.
- When the headlights are not bright due to dirt on the lens or if the aiming is not adjusted properly.
- When strong light enters the lane camera unit. (For example, the light directly shines on the front of the vehicle at sunrise or sunset.)
- When a sudden change in brightness occurs. (For example, when the vehicle enters or exits a tunnel or under a bridge.)

While the LDP system is operating, you may

hear a sound of brake operation. This is normal and indicates that the LDP system is operating properly.

SYSTEM TEMPORARILY UNAVAILABLE

Condition A:

The warning and assist functions of the LDP system are not designed to work under the following conditions:

- When you operate the lane change signal and change the traveling lanes in the direction of the signal. (The LDP system will be deactivated for approximately 2 seconds after the lane change signal is turned off.)
- When the vehicle speed lowers to less than approximately 37 MPH (60 km/h).

Action to take:

After the above conditions have finished and the necessary operating conditions are satisfied, the warning and assist functions will resume.

Condition B:

The assist function of the LDP system is not designed to work under the following conditions (warning is still functional):

- When the brake pedal is depressed.

- When the steering wheel is turned as far as necessary for the vehicle to change lanes.
- When the vehicle is accelerated during the LDP system operation.
- When the Adaptive Cruise Control System (ACC) approach warning occurs (if so equipped).
- When the hazard warning flashers are operated.
- When driving on a curve at high speed.

Action to take:

After the above conditions have finished and the necessary operating conditions are satisfied, the LDP system application of the brakes will resume.

Condition C:

If the following message appears in the multi-information display, a chime will sound and the LDP system will be turned off automatically.

- “Currently Not Available”:
 - When the ASC is turned off.
 - When the SNOW mode, GRAVEL mode or MUD mode (AWC model) is selected.

Action to take:

When the above conditions no longer exist, turn off the LDP system. Push the MI-PILOT Assist switch again to turn the LDP system back on.

Temporary disabled status at high temperature:

If the vehicle is parked in direct sunlight under high temperature conditions (over approximately 104°F (40°C)) and then the LDP system is turned on, the LDP system may be deactivated automatically and the following message will appear on the multi-information display: “Unavailable High Cabin Temperature”. When the interior temperature is reduced, the system will resume operating automatically.

SYSTEM MALFUNCTION

If the LDP system malfunctions, it will cancel automatically. The LDP indicator (orange) will illuminate and the “Not Available System Malfunction” warning message will appear in the multi-information display.

If the LDP indicator (orange) illuminates, pull off the road to a safe location. Turn the engine off and restart the engine. If the LDP indicator (orange) continues to illuminate, have the LDP system checked. It is recommended that you visit an authorized Mitsubishi Motors dealer for this service.

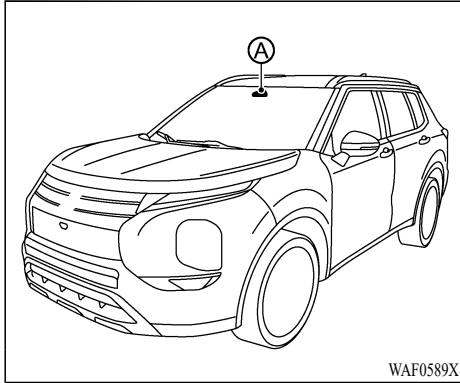

SYSTEM MAINTENANCE

The lane camera unit (A) for the LDP system is located above the inside mirror. To keep the proper operation of the LDP system and prevent a system malfunction, be sure to observe the following:

- Always keep the windshield clean.
- Do not attach a sticker (including transparent material) or install an accessory near the camera unit.
- Do not place reflective materials, such as white paper or a mirror, on the instrument panel. The reflection of sunlight may adversely affect the camera unit's capability of detecting the lane markers.

- Do not strike or damage the areas around the camera unit. Do not touch the camera lens or remove the screw located on the camera unit. If the camera unit is damaged due to an accident, it is recommended that you visit an authorized Mitsubishi Motors dealer.

BLIND SPOT WARNING (BSW)

WARNING

Failure to follow the warnings and instructions for proper use of the BSW system could result in serious injury or death.

- The BSW system is not a replacement for proper driving procedure and is not designed to prevent contact with vehicles or objects. When changing lanes, always use the side and rear mirrors and turn and look in the direction your vehicle will move to ensure it is safe to change lanes. Never rely solely on the BSW system.

The BSW system helps alert the driver of other vehicles in adjacent lanes when changing lanes.

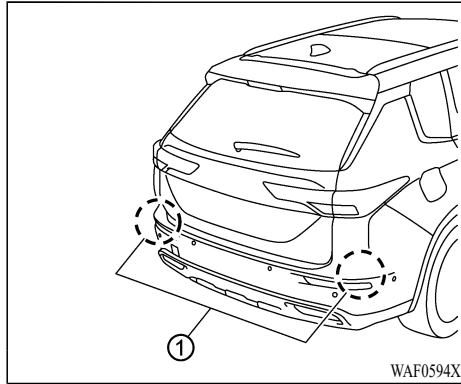

The BSW system uses radar sensors ① installed near the rear bumper to detect other vehicles in an adjacent lane.

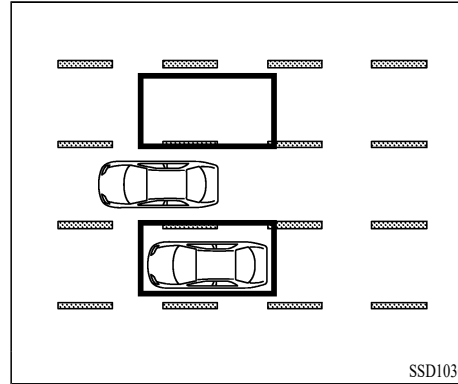

Detection zone

The radar sensors can detect vehicles on either side of your vehicle within the detection zone shown as illustrated. This detection zone starts from the door mirror of your vehicle and extends approximately 10 ft (3.0 m) behind the rear bumper, and approximately 10 ft (3.0 m) sideways.

When the turn signal is activated, the detection zone may extend more than approximately 10 ft (3.0 m).

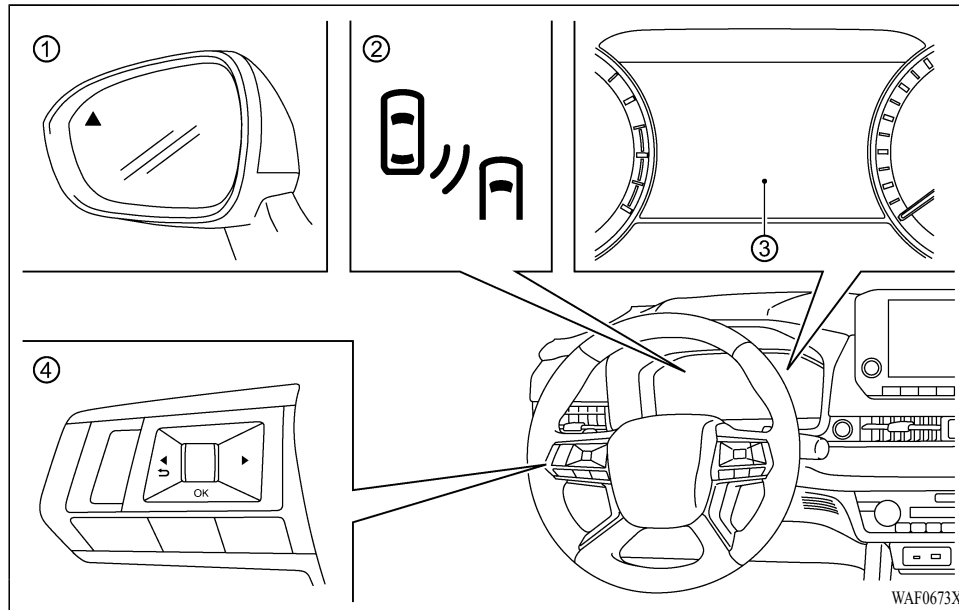

- ① Side indicator light
- ② BSW indicator (on the multi-information display)
- ③ Multi-information display
- ④ Steering wheel remote control switches (left side)

BSW SYSTEM OPERATION

The BSW system operates above approximately 6 MPH (10 km/h).

If the radar sensors detect a vehicle in the detection zone, the side indicator light ① illuminates.

If the turn signal is then activated, the system chimes (twice) and the side indicator light flashes. The side indicator light continues to flash until the detected vehicle leaves the detection zone.

The side indicator light illuminates for a few seconds when the ignition switch is placed in the ON position.

The brightness of the side indicator light is adjusted automatically depending on the brightness of the ambient light.

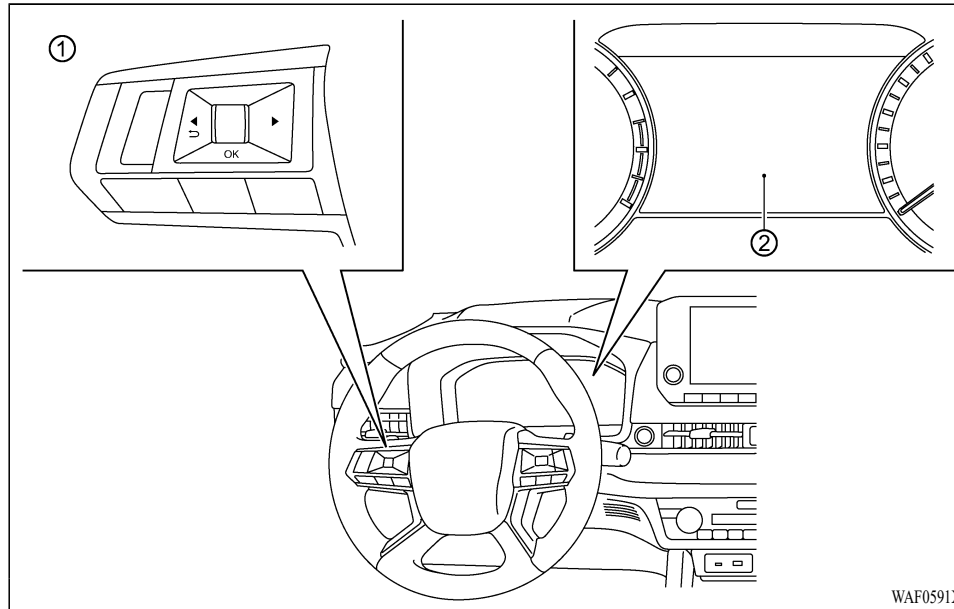

- ① Steering wheel remote control switches (left side)
- ② Multi-information display

HOW TO ENABLE/DISABLE THE BSW SYSTEM

Perform the following steps to enable or disable the BSW system.

1. Press the ◀ ▶ button until “Settings” appears in the multi-information display ②

and then push the scroll dial. Use the scroll dial to select “Driver Assistance”. Then push the scroll dial.

2. Select “Blind Spot” and push the scroll dial.
3. Select “Warning (BSW)” and push the scroll dial.

NOTE:

The system will retain current settings in the multi-information display even if the engine is restarted.

BSW SYSTEM LIMITATIONS

WARNING

Listed below are the system limitations for the BSW system. Failure to operate the vehicle in accordance with these system limitations could result in serious injury or death.

- The BSW system cannot detect all vehicles under all conditions.
- The radar sensors may not be able to detect and activate BSW when certain objects are present such as:
 - Pedestrians, bicycles, animals.
 - Vehicles such as motorcycles, low height vehicles, or high ground clearance vehicles.

- **Oncoming vehicles.**
- **Vehicles remaining in the detection zone when you accelerate from a stop.**
- **A vehicle merging into an adjacent lane at a speed approximately the same as your vehicle.**
- **A vehicle approaching rapidly from behind.**
- **A vehicle which your vehicle overtakes rapidly.**
- **A vehicle that passes through the detection zone quickly.**
- **When overtaking several vehicles in a row, the vehicles after the first vehicle may not be detected if they are traveling close together.**

- **The radar sensor's detection zone is designed based on a standard lane width. When driving in a wider lane, the radar sensors may not detect vehicles in an adjacent lane. When driving in a narrow lane, the radar sensors may detect vehicles driving two lanes away.**
- **The radar sensors are designed to ignore most stationary objects, however objects such as guardrails, walls, foliage and parked vehicles may occasionally be detected. This is a normal operation condi-**

tion.

- **The following conditions may reduce the ability of the radar to detect other vehicles:**
 - **Severe weather**
 - **Road spray**
 - **Ice/frost/dirt build-up on the vehicle**
- **Do not attach stickers (including transparent material), install accessories or apply additional paint near the radar sensors. These conditions may reduce the ability of the radar to detect other vehicles.**
- **Excessive noise (for example, audio system volume, open vehicle window) will interfere with the chime sound, and it may not be heard.**

BSW DRIVING SITUATIONS

Indicator on



Indicator off



Indicator flashing



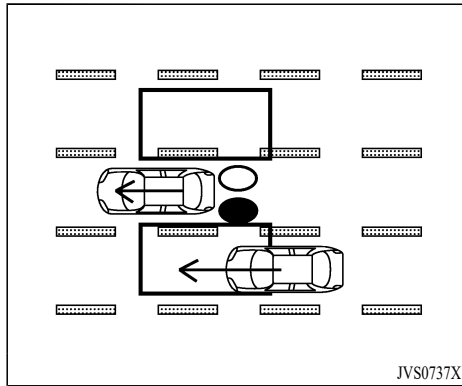

Illustration 1 – Approaching from behind

Another vehicle approaching from behind

Illustration 1: The side indicator light illuminates if a vehicle enters the detection zone from behind in an adjacent lane.

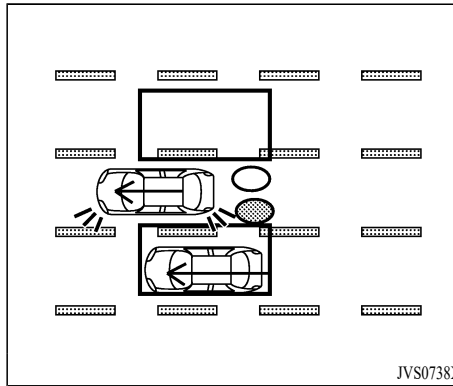

Illustration 2 – Approaching from behind

Illustration 2: If the driver activates the turn signal while another vehicle is in the detection zone, then the system chimes (twice) and the side indicator light flashes.

NOTE:

- The radar sensors may not detect vehicles which are approaching rapidly from behind.

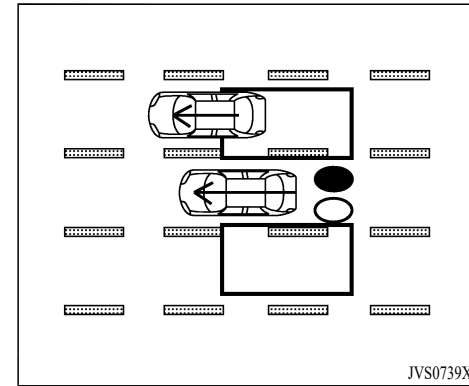

Illustration 3 – Overtaking another vehicle

Overtaking another vehicle

Illustration 3: The side indicator light illuminates if you overtake a vehicle and that vehicle stays in the detection zone for approximately 2 seconds.

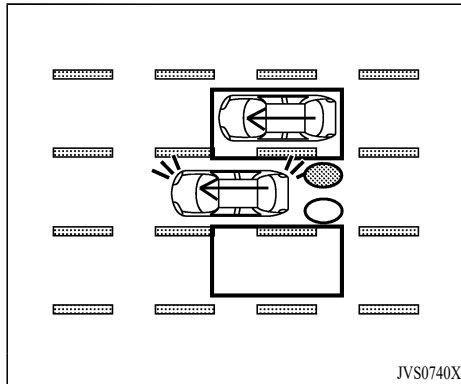

Illustration 4 – Overtaking another vehicle

Illustration 4: If the driver activates the turn signal while another vehicle is in the detection zone, then the system chimes (twice) and the side indicator light flashes.

NOTE:

- When overtaking several vehicles in a row, the vehicles after the first vehicle may not be detected if they are traveling close together.
- The radar sensors may not detect slower moving vehicles if they are passed quickly.

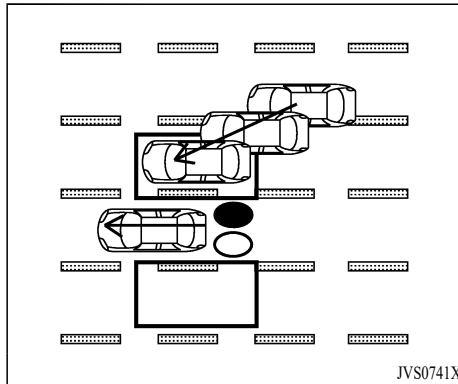

Illustration 5 – Entering from the side

Entering from the side

Illustration 5: The side indicator light illuminates if a vehicle enters the detection zone from either side.

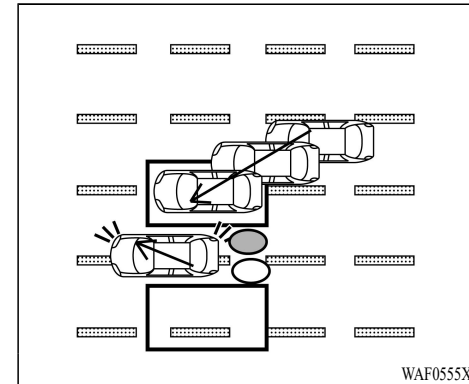

Illustration 6 – Entering from the side

Illustration 6: If the driver activates the turn signal while another vehicle is in the detection zone, then the system chimes (twice) and the side indicator light flashes.

NOTE:

- The radar sensors may not detect a vehicle which is traveling at about the same speed as your vehicle when it enters the detection zone.

SYSTEM TEMPORARILY UN-AVAILABLE

When radar blockage is detected, the BSW system will be turned off automatically, a chime will sound and the “Unavailable Side Radar Obstruction” warning message will appear in the multi-information display.

The system is not available until the conditions no longer exist.

The radar sensors may be blocked by temporary ambient conditions such as splashing water, mist or fog. The blocked condition may also be caused by objects such as ice, frost or dirt obstructing the radar sensors.

NOTE:

If the BSW system stops working, the Active Blind Spot Assist (ABSA) (if so equipped) and the RCTA system will also stop working.

Action to take:

When the above conditions no longer exist, the system will resume automatically.

SYSTEM MALFUNCTION

When the BSW system malfunctions, it will be turned off automatically, the BSW indicator illuminates and the “Not Available System Malfunction” warning message will appear in the multi-information display.

5-50 Starting and driving

NOTE:

If the BSW system stops working, the Active Blind Spot Assist (ABSA) (if so equipped) and the Rear Cross Traffic Alert (RCTA) system will also stop working.

Action to take:

Stop the vehicle in a safe location, turn the engine off and restart the engine. If the message continues to appear, have the BSW system checked. It is recommended that you visit an authorized Mitsubishi Motors dealer for this service.

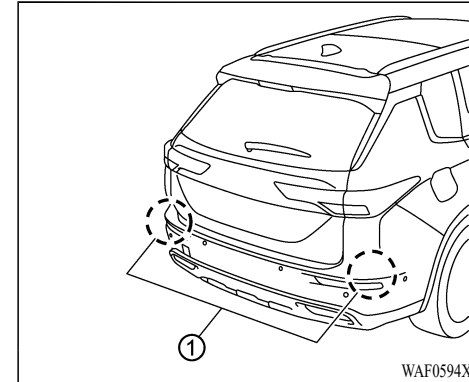

SYSTEM MAINTENANCE

The two radar sensors ① for the BSW system are located near the rear bumper. Always keep the area near the radar sensors clean.

The radar sensors may be blocked by temporary ambient conditions such as splashing water, mist or fog.

The blocked condition may also be caused by objects such as ice, frost or dirt obstructing the radar sensors.

Check for and remove objects obstructing the area around the radar sensors.

Do not attach stickers (including transparent material), install accessories or apply additional

paint near the radar sensors.

Do not strike or damage the area around the radar sensors.

See an authorized Mitsubishi Motors dealer or other authorized repair shop if the area around the radar sensors is damaged due to a collision.

Radio frequency statement

For USA

FCC ID: LTQRN5TR

CAUTION TO USERS

Changes or modifications not expressly approved by the party responsible for compliance could void the user's authority to operate the equipment.

This device complies with Part 15 of the FCC Rules and with RSS of the Industry Canada. Operation is subject to the following two conditions:

- (1) This device may not cause harmful interference, and
- (2) this device must accept any interference received, including interference that may cause undesired operation

For Canada

Model: RN5TR

IC: 3659A-RN5TR

This device complies with Industry Canada

licence-exempt RSS standard(s). Operation is subject to the following two conditions: (1) this device may not cause interference, and (2) this device must accept any interference, including interference that may cause undesired operation of the device.

Le présent appareil est conforme aux CNR d'Industrie Canada applicables aux appareils radio exempts de licence. L'exploitation est autorisée aux deux conditions suivantes: (1) l'appareil ne doit pas produire de brouillage, et (2) l'utilisateur de l'appareil doit accepter tout brouillage radioélectrique subi, même si le brouillage est susceptible d'en compromettre le fonctionnement.

ACTIVE BLIND SPOT ASSIST (ABSA) (if so equipped)

WARNING

Failure to follow the warnings and instructions for proper use of the ABSA system could result in serious injury or death.

- The ABSA system is not a replacement for proper driving procedures and is not designed to prevent contact with vehicles or objects. When changing lanes, always use the side and rear mirrors and turn and look in the direction your vehicle will move to ensure it is safe to change lanes. Never rely solely on the ABSA system.
- There is a limitation to the detection capability of the radar. Not every moving object or vehicle will be detected. Using the ABSA system under some road, ground, lane marker, traffic or weather conditions could lead to improper system operation. Always rely on your own operation to avoid accidents.

The ABSA system helps alert the driver of other vehicles in adjacent lanes when changing lanes, and helps assist the driver to return the vehicle to the center of the traveling lane.

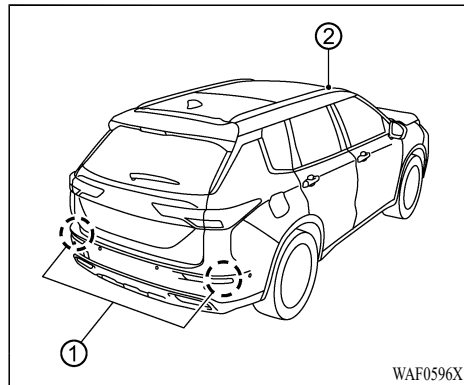

The ABSA system uses radar sensors ① installed near the rear bumper to detect other vehicles in an adjacent lane. In addition to the radar sensors, the ABSA system uses a camera ② installed behind the windshield to monitor the lane markers of your traveling lane.

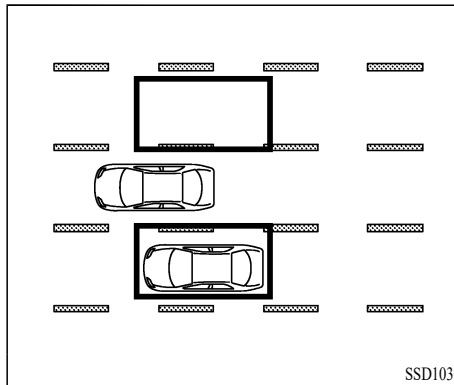

Detection zone

The radar sensors can detect vehicles on either side of your vehicle within the detection zone shown as illustrated.

This detection zone starts from the door mirror of your vehicle and extends approximately 10 ft (3.0 m) behind the rear bumper, and approximately 10 ft (3.0 m) sideways.

5-52 Starting and driving

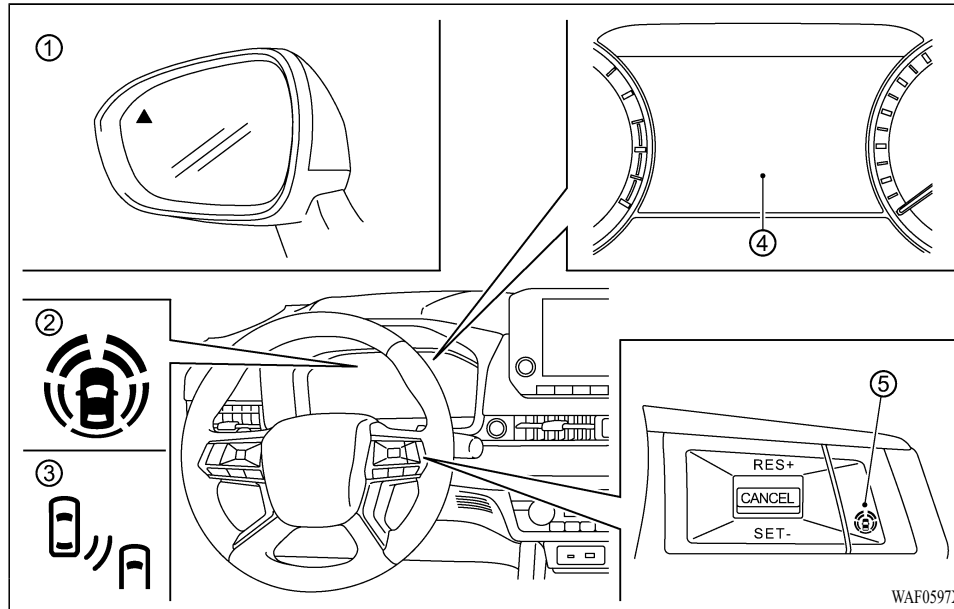

- ① Side indicator light
- ② ABSA ON indicator (on the multi-information display)
- ③ ABSA indicator (on the multi-information display)
- ④ Multi-information display
- ⑤ MI-PILOT Assist switch

ABSA SYSTEM OPERATION

The ABSA system operates above approximately 37 MPH (60 km/h).

If the radar sensors detect a vehicle in the detection zone, the side indicator light ① illuminates.

If the turn signal is then activated, the system chimes (twice) and the side indicator light flashes. The side indicator light continues to flash until the detected vehicle leaves the detection zone.

If the ABSA system is ON and your vehicle approaches a lane marker while another vehicle is in the detection zone, the system chimes (three times) and the side indicator light flashes. The ABSA system activates to help return the vehicle back to the center of the driving lane. The ABSA system operates regardless of turn signal usage.

To turn on the ABSA system, push the MI-PILOT Assist switch on the steering wheel after starting the engine. The ABSA ON indicator on the multi-information display will illuminate. Push the MI-PILOT Assist switch again to turn off the ABSA system.

NOTE:

- **ABSA warning and system application will only be activated if the side indicator light is already illuminated when your vehicle approaches a lane marker. If another vehicle comes into the detection zone after your vehicle has crossed a lane marker, no ABSA warning or system application will be activated. (For additional information, see “ABSA driving situations” (P.5-56).)**

- The ABSA system is typically activated earlier than the Lane Departure Prevention (LDP) system when your vehicle is approaching a lane marker.

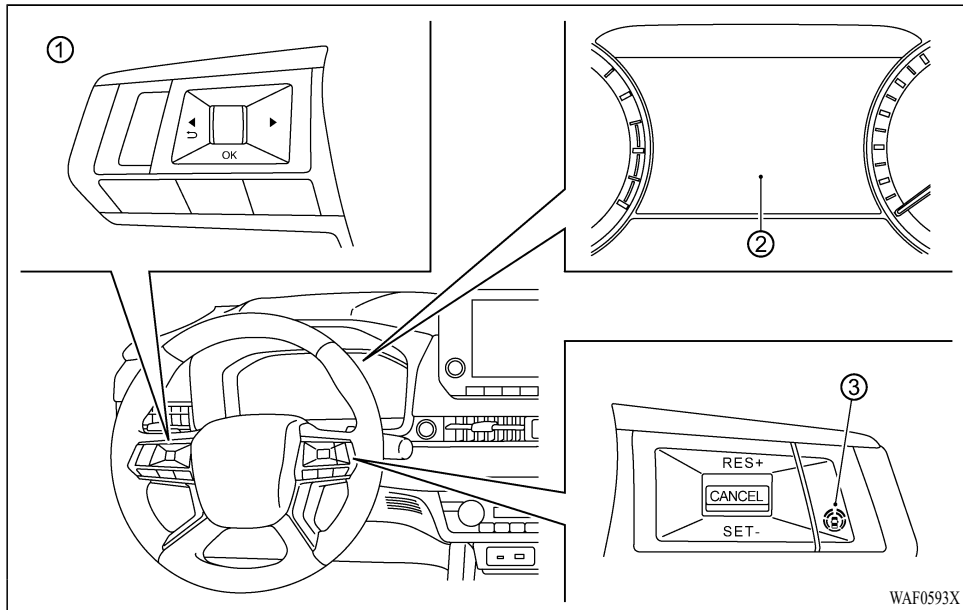

- ① Steering wheel remote control switches (left side)
- ② Multi-information display
- ③ MI-PILOT Assist switch

HOW TO ENABLE/DISABLE THE ABSA SYSTEM

1. Press the ◀ ▶ button until “Settings” appears in the multi-information display ② and then push the scroll dial. Use the scroll dial to select “Driver Assistance.” Then push the scroll dial.

2. Select “Blind Spot” and push the scroll dial.
3. Select “Active Assist (ABSA)” and push the scroll dial.
4. Press the MI-PILOT Assist switch ③ to turn the system on or off.

NOTE:

Turning on the MI-PILOT Assist system will turn on the LDP and ABSA system at the same time. For additional information, see “Lane Departure Prevention (LDP)” (P.5-38).

Turning the BSW system off will deactivate the ABSA system at the same time.

ABSA SYSTEM LIMITATIONS
 **WARNING**

Listed below are the system limitations for the ABSA system. Failure to operate the vehicle in accordance with these system limitations could result in serious injury or death.

- The ABSA system cannot detect all vehicles under all conditions.
- The radar sensors may not be able to detect and activate ABSA when certain objects are present such as:
 - Pedestrians, bicycles, animals.

- Vehicles such as motorcycles, low height vehicles, or high ground clearance vehicles.

- Vehicles remaining in the detection zone when you accelerate from a stop.

- Oncoming vehicles.

- A vehicle merging into an adjacent lane at a speed approximately the same as your vehicle.

- A vehicle approaching rapidly from behind.

- A vehicle which your vehicle overtakes rapidly.

- A vehicle that passes through the detection zone quickly.

- The radar sensor’s detection zone is designed based on a standard lane width. When driving in a wider lane, the radar sensors may not detect vehicles in an adjacent lane. When driving in a narrow lane, the radar sensors may detect vehicles driving two lanes away.
- The radar sensors are designed to ignore most stationary objects, however objects such as guardrails, walls, foliage and parked vehicles may occasionally be detected. This is a normal operation condition.

- The following conditions may reduce the ability of the radar to detect other vehicles:

- Severe weather

- Road spray

- Ice/frost/dirt build-up on the vehicle

- Do not attach stickers (including transparent material), install accessories or apply additional paint near the radar sensors. These conditions may reduce the ability of the radar to detect other vehicles.

- The camera may not detect lane markers in the following situations and the ABSA system may not operate properly.

- On roads where there are multiple parallel lane markers; lane markers that are faded or not painted clearly; yellow painted lane markers; nonstandard lane markers; lane markers covered with water, dirt, snow, etc.

- On roads where discontinued lane markers are still detectable.

- On roads where there are sharp curves.

- On roads where there are sharply contrasting objects, such as shadows, snow, water, wheel ruts,

seams or lines remaining after road repairs.

- On roads where the traveling lane merges or separates.
- When the vehicle's traveling direction does not align with the lane markers.
- When traveling close to the vehicle in front of you, which obstructs the lane camera unit detection range.
- When rain, snow or dirt adheres to the windshield in front of a lane camera unit.
- When the headlights are not bright due to dirt on the lens or if aiming is not adjusted properly.
- When strong light enters a lane camera unit. (For example: light directly shines on the front of the vehicle at sunrise or sunset.)
- When a sudden change in brightness occurs. (For example: when the vehicle enters or exits a tunnel or under a bridge.)
- Do not use the ABSA system under the following conditions because the system may not function properly.

- During bad weather. (For example: rain, fog, snow, etc.)
- When driving on slippery roads, such as on ice or snow, etc.
- When driving on winding or uneven roads.
- When there is a lane closure due to road repairs.
- When driving in a makeshift or temporary lane.
- When driving on roads where the lane width is too narrow.
- When driving with a tire that is not within normal tire conditions (for example, tire wear, low tire pressure, installation of tire chains, non-standard wheels).
- When the vehicle is equipped with non-original steering parts or suspension parts.
- When towing a trailer or other vehicle.
- Excessive noise (for example, audio system volume, open vehicle window) will interfere with the chime sound, and it may not be heard.

While the ABSA system is operating, you may hear a sound of brake operation. This is normal and indicates that the ABSA system is operating properly.

ABSA DRIVING SITUATIONS

Indicator on



Indicator off



Indicator flashing



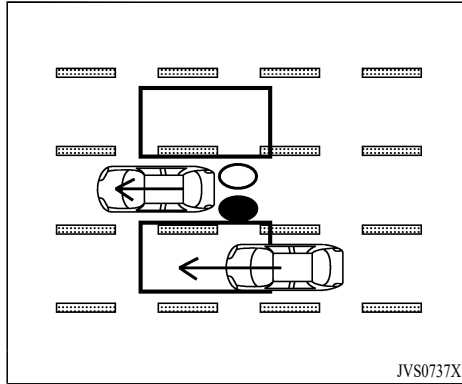

Illustration 1 – Approaching from behind

Another vehicle approaching from behind

Illustration 1: The side indicator light illuminates if a vehicle enters the detection zone from behind in an adjacent lane.

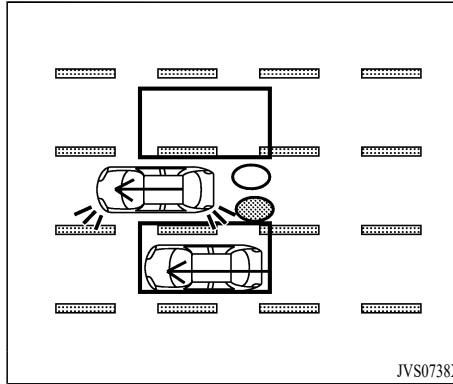

Illustration 2 – Approaching from behind

Illustration 2: If the driver activates the turn signal then the system chimes a sound (twice) and the side indicator light flashes.

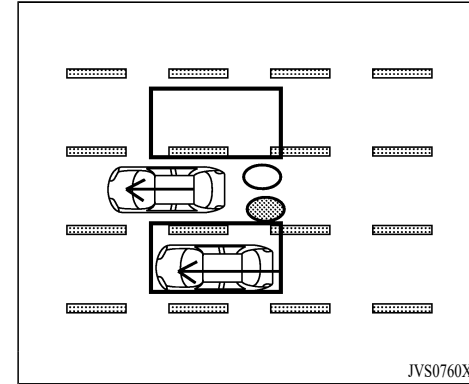

Illustration 3 - Approaching from behind

Illustration 3: If the ABSA system is on and your vehicle approaches a lane marker while another vehicle is in the detection zone, the system chimes (three times) and the side indicator light flashes. The ABSA system activates to help return the vehicle back to the center of the driving lane.

NOTE:

- The radar sensors may not detect vehicles which are approaching rapidly from behind.

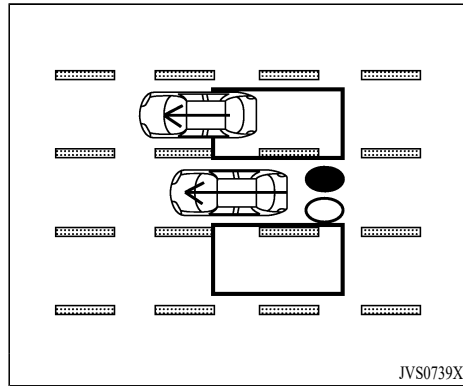

Illustration 4 - Overtaking another vehicle

Overtaking another vehicle

Illustration 4: The side indicator light illuminates if you overtake a vehicle and that vehicle stays in the detection zone for approximately 3 seconds.

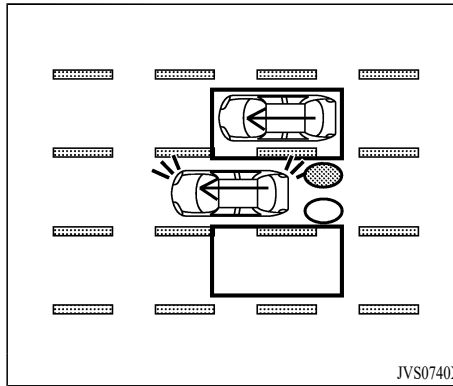

Illustration 5 - Overtaking another vehicle

Illustration 5: If the driver activates the turn signal while another vehicle is in the detection zone, then the system chimes (twice) and the side indicator light flashes.

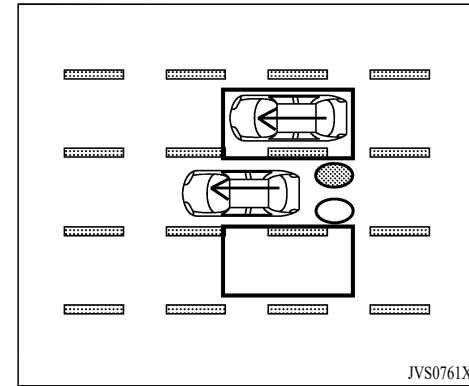

Illustration 6 - Overtaking another vehicle

Illustration 6: If the ABSA system is on and your vehicle approaches a lane marker while another vehicle is in the detection zone, the system chimes (three times) and the side indicator light flashes. The ABSA system activates to help return the vehicle back to the center of the driving lane.

NOTE:

- When overtaking several vehicles in a row, the vehicles after the first vehicle may not be detected if they are traveling close together.
- The radar sensors may not detect slower moving vehicles if they are passed quickly.

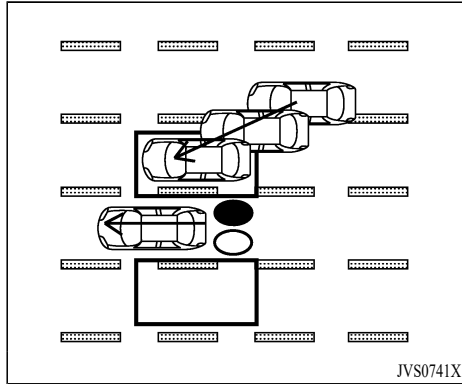

Illustration 7 - Entering from the side

Entering from the side

Illustration 7: The side indicator light illuminates if a vehicle enters the detection zone from either side.

NOTE:

The radar sensors may not detect a vehicle which is traveling at about the same speed as your vehicle when it enters the detection zone.

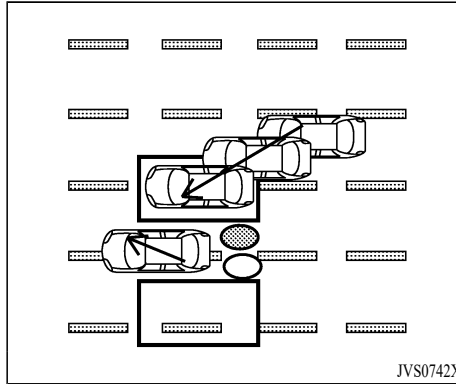

Illustration 8 - Entering from the side

Illustration 8: If the driver activates the turn signal while another vehicle is in the detection zone, then the side indicator light flashes and a chime will sound twice.

NOTE:

If the driver activates the turn signal before a vehicle enters the detection zone, the side indicator light will flash but no chime will sound when another vehicle is detected.

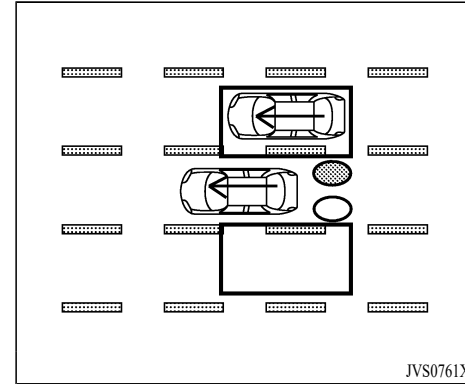

Illustration 9 - Entering from the side

Illustration 9: If the ABSA system is on and your vehicle approaches the lane marker while another vehicle is in the detection zone, the system chimes (three times) and the side indicator light flashes. The ABSA system activates to help return the vehicle back to the center of the driving lane.

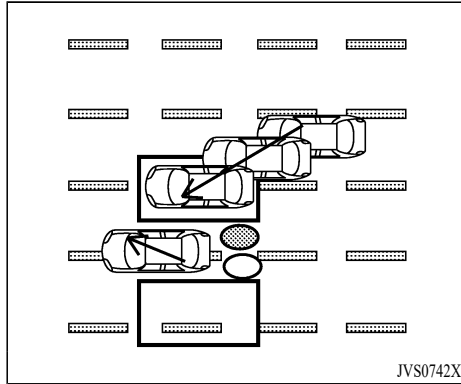

Illustration 10 - Entering from the side

Illustration 10: The ABSA system will not operate if your vehicle is on a lane marker when another vehicle enters the detection zone. In this case only the BSW system operates.

NOTE:

- **The radar sensors may not detect a vehicle which is traveling at about the same speed as your vehicle when it enters the detection zone.**
- **ABSA will not operate or will stop operating and only a warning chime will sound under the following conditions.**
 - **When the brake pedal is depressed.**

- **When the vehicle is accelerated during ABSA system operation.**
- **When steering quickly.**
- **When the ACC, PFCW or FCM warnings sound.**
- **When the hazard warning flashers are operated.**
- **When driving on a curve at a high speed.**
- **When the BSW system is turned off.**

SYSTEM TEMPORARILY UNAVAILABLE

When any of the following messages appear on the multi-information display, a chime will sound and the ABSA system will be turned off automatically.

- **“Not Available Poor Road Conditions”:**
When the ASC system (except traction control system function) or ABS operates.
- **“Currently Not Available”:**
 - When the ASC is turned off.
 - When the SNOW mode, GRAVEL mode or MUD mode (AWC model) is selected.
- **“Unavailable High Cabin Temperature”:**
If the vehicle is parked in direct sunlight under high temperature conditions (over approximately 104°F (40°C)).

- **“Unavailable Side Radar Obstruction”:**

When side radar blockage is detected.

Turn off the ABSA system and turn it on again when the above conditions no longer exist.

SYSTEM MALFUNCTION

When the ABSA system malfunctions, it will be turned off automatically, the ABSA indicator illuminates, a chime will sound, and the warning message will appear in the multi-information display.

Action to take:

Stop the vehicle in a safe location and push the park button to shift to the P (Park) position. Turn the engine off and restart the engine. If the warning message continues to appear, It is recommended you visit an authorized Mitsubishi Motors dealer for this service.

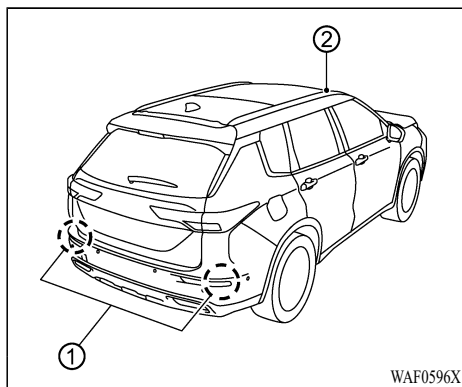

SYSTEM MAINTENANCE

The two radar sensors ① for the ABSA system are located near the rear bumper. Always keep the area near the radar sensors clean.

The radar sensors may be blocked by temporary ambient conditions such as splashing water, mist or fog.

The blocked condition may also be caused by objects such as ice, frost or dirt obstructing the radar sensors.

Check for and remove objects obstructing the area around the radar sensors.

Do not attach stickers (including transparent material), install accessories or apply additional

paint near the radar sensors.

Do not strike or damage the area around the radar sensors.

It is recommended you visit an authorized Mitsubishi Motors dealer if the area around the radar sensors is damaged due to a collision.

The lane camera unit ② for ABSA system is located above the inside mirror. To keep the proper operation of ABSA and prevent a system malfunction, be sure to observe the following:

- Always keep the windshield clean.
- Do not attach a sticker (including transparent material) or install an accessory near the camera unit.
- Do not place reflective materials, such as white paper or a mirror, on the instrument panel. The reflection of sunlight may adversely affect the camera unit's capability of detecting the lane markers.
- Do not strike or damage the areas around the camera unit. Do not touch the camera lens or remove the screw located on the camera unit. It is recommended you contact an authorized Mitsubishi Motors dealer if the camera unit is damaged due to an accident.

Radio frequency statement

For USA

FCC ID: LTQRN5TR

CAUTION TO USERS

Changes or modifications not expressly approved by the party responsible for compliance could void the user's authority to operate the equipment.

This device complies with Part 15 of the FCC Rules and with RSS of the Industry Canada. Operation is subject to the following two conditions:

(1) This device may not cause harmful interference, and

(2) this device must accept any interference received, including interference that may cause undesired operation

For Canada

Model: RN5TR

IC: 3659A-RN5TR

This device complies with Industry Canada licence-exempt RSS standard(s). Operation is subject to the following two conditions: (1) this device may not cause interference, and (2) this device must accept any interference, including interference that may cause undesired operation of the device.

Starting and driving 5-61

REAR CROSS TRAFFIC ALERT (RCTA)

Le présent appareil est conforme aux CNR d'Industrie Canada applicables aux appareils radio exempts de licence. L'exploitation est autorisée aux deux conditions suivantes: (1) l'appareil ne doit pas produire de brouillage, et (2) l'utilisateur de l'appareil doit accepter tout brouillage radioélectrique subi, même si le brouillage est susceptible d'en compromettre le fonctionnement.

WARNING

Failure to follow the warnings and instructions for proper use of the RCTA system could result in serious injury or death.

- **The RCTA system is not a replacement for proper driving procedures and is not designed to prevent contact with vehicles or objects. When backing out of a parking space, always use the side and rear mirrors and turn and look in the direction your vehicle will move. Never rely solely on the RCTA system.**

The RCTA system will assist you when backing out from a parking space. When the vehicle is in reverse, the system is designed to detect other vehicles approaching from the right or left of the vehicle. If the system detects cross traffic, it will alert you.

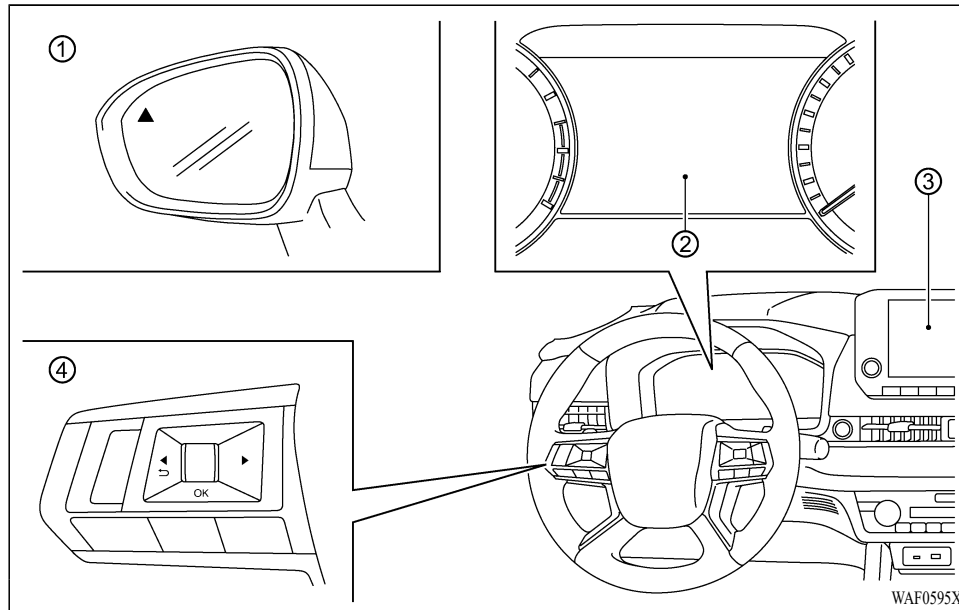

- ① Side indicator light
- ② Multi-information display
- ③ Smartphone-link Display Audio (SDA) screen
- ④ Steering wheel remote control switches (left side)

RCTA SYSTEM OPERATION

The RCTA system can help alert the driver of an approaching vehicle when the driver is backing out of a parking space.

When the shift position is in R (Reverse) and the vehicle speed is less than approximately 5 MPH (8 km/h), the RCTA system is operational.

If the radar detects an approaching vehicle from either side, the system chimes (once), the side indicator light ① flashes on the side the vehicle is approaching from, and a yellow rectangular frame appears in the rear view display on the Smartphone-link Display Audio (SDA) screen ③.

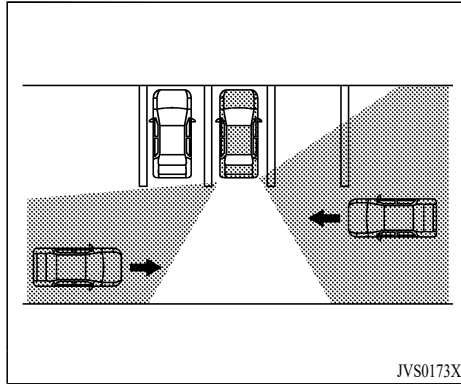

The RCTA system uses radar sensors ① installed on both sides near the rear bumper to detect an approaching vehicle.

The radar sensors ① can detect an approaching vehicle from up to approximately 66 ft (20 m) away.

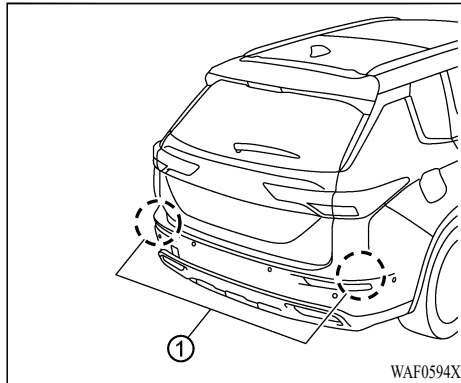

5-64 Starting and driving

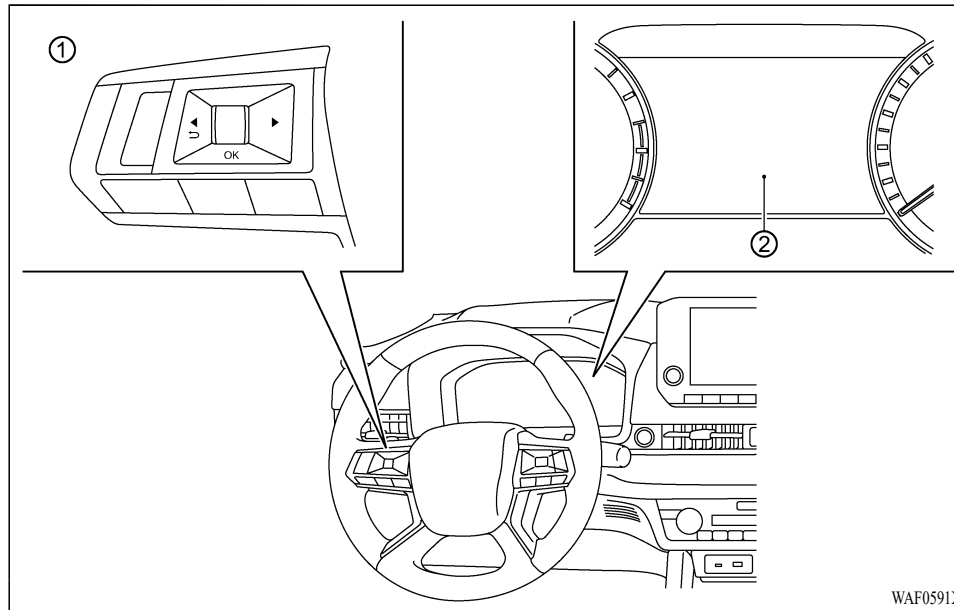

- ① Steering wheel remote control switches (left side)
- ② Multi-information display

HOW TO ENABLE/DISABLE THE RCTA SYSTEM

Perform the following steps to enable or disable the RCTA system.

1. Press the ◀ ▶ button until “Settings” appears in the multi-information display ②

and then push the scroll dial. Use the scroll dial to select “Driver Assistance”. Then push the scroll dial.

2. Use the button to select “Rear Cross Traffic Alert” then press the scroll dial.
3. Use the scroll dial to enable or disable the system.

NOTE:

The system setting will be retained even if the engine is restarted.

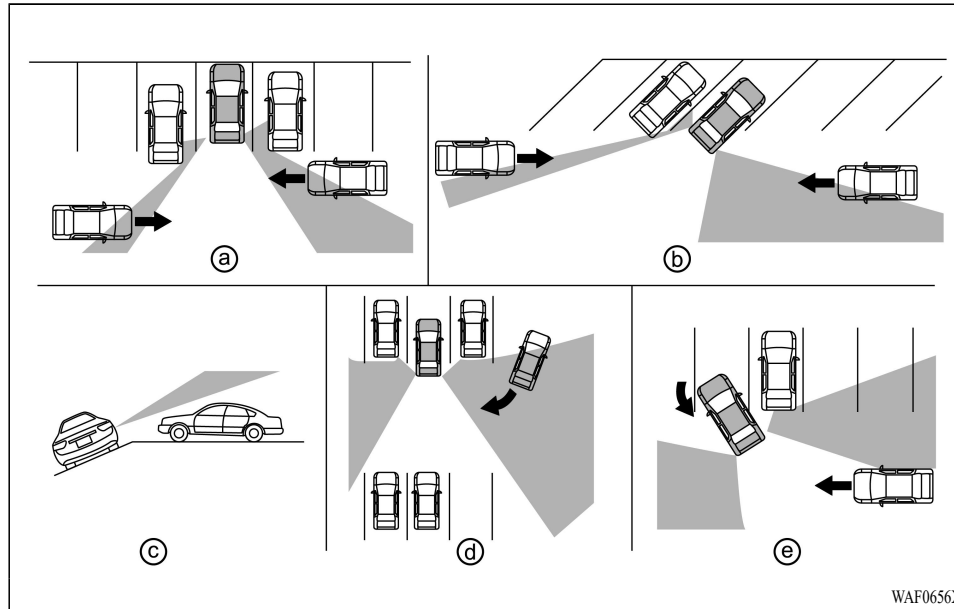

RCTA SYSTEM LIMITATIONS

WARNING

Listed below are the system limitations for the RCTA system. Failure to operate the vehicle in accordance with these system limitations could result in serious injury or death.

- Always check surroundings and turn to check what is behind you before backing up. The radar sensors detect approaching (moving) vehicles. The radar sensors cannot detect every object such as:
 - Pedestrians, bicycles, motorcycles, animals or child-operated toy vehicles
 - A vehicle that is passing at speeds greater than approximately 19 MPH (30 km/h)
 - A vehicle that is passing at speeds lower than approximately 5 MPH (8 km/h)
- The radar sensors may not detect approaching vehicles in certain situations:
 - **Illustration (a):** When a vehicle parked next to you obstructs the beam of the radar sensor.

- Illustration ①: When the vehicle is parked in an angled parking space.
- Illustration ②: When the vehicle is parked on inclined ground.
- Illustration ③: When an approaching vehicle turns into your vehicle's parking lot aisle.
- Illustration ④: When the angle formed by your vehicle and approaching vehicle is small.

- The following conditions may reduce the ability of the radar to detect other vehicles:
 - Severe weather
 - Road spray
 - Ice/frost/dirt build-up on the vehicle
- Do not attach stickers (including transparent material), install accessories or apply additional paint near the radar sensors. These conditions may reduce the ability of the radar to detect other vehicles.
- Excessive noise (e.g. audio system volume, open vehicle window) will interfere with the chime sound, and it may not be heard.

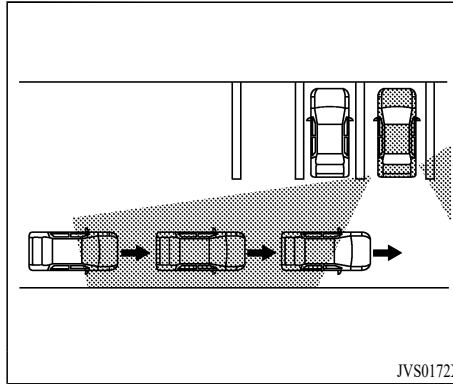

Illustration 1

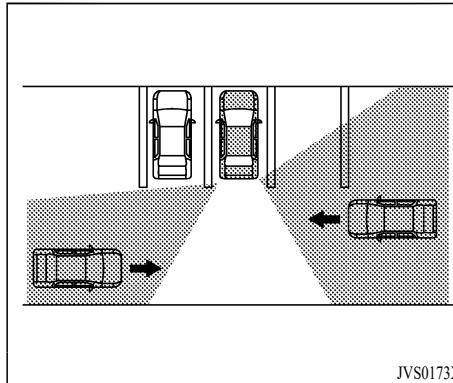

Illustration 2

NOTE:

In the case of several vehicles approaching in a row (Illustration 1) or in the opposite direction (Illustration 2), a chime may not be sounded by the RCTA system after the first vehicle passes the sensors.

SYSTEM TEMPORARILY UNAVAILABLE

When radar blockage is detected, the system will be deactivated automatically. The “Unavailable: Side Radar Obstruction” warning message will appear in the multi-information display.

The systems are not available until the conditions no longer exist.

The radar sensors may be blocked by temporary ambient conditions such as splashing water, mist or fog.

The blocked condition may also be caused by objects such as ice, frost or dirt obstructing the radar sensors.

NOTE:

If the BSW system stops working, the RCTA and Active Blind Spot Assist (ABSA) systems will also stop working.

Action to take:

When the above conditions no longer exist, the system will resume automatically.

SYSTEM MALFUNCTION

When the RCTA system malfunctions, it will turn off automatically. The “Malfunction” warning message will appear in the multi-information display.

NOTE:

If the BSW system stops working, the RCTA and ABSA systems will also stop working.

Action to take:

Stop the vehicle in a safe location, turn the engine off and restart the engine. If the message continues to appear, have the system checked. It is recommended that you visit an authorized Mitsubishi Motors dealer for this service.

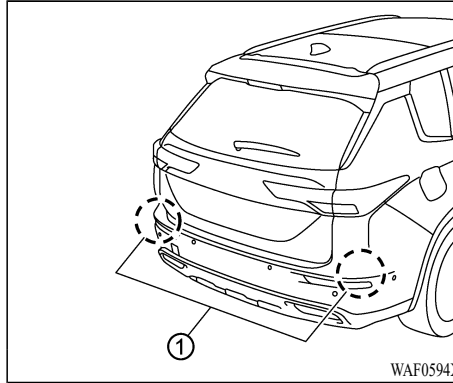
**SYSTEM MAINTENANCE**

The two radar sensors ① for the RCTA system are located near the rear bumper. Always keep the area near the radar sensors clean.

The radar sensors may be blocked by temporary ambient conditions such as splashing water, mist or fog.

The blocked condition may also be caused by objects such as ice, frost or dirt obstructing the radar sensors.

Check for and remove objects obstructing the area around the radar sensors.

Do not attach stickers (including transparent material), install accessories or apply additional

paint near the radar sensors.

Do not strike or damage the area around the radar sensors. It is recommended that you visit an authorized Mitsubishi Motors dealer if the area around the radar sensors is damaged due to a collision.

Radio frequency statement

For USA

FCC ID: LTQRN5TR

CAUTION TO USERS

Changes or modifications not expressly approved by the party responsible for compliance could void the user's authority to operate the equipment.

This device complies with Part 15 of the FCC Rules and with RSS of the Industry Canada. Operation is subject to the following two conditions:

(1) This device may not cause harmful interference, and

(2) this device must accept any interference received, including interference that may cause undesired operation

For Canada

Model: RN5TR

IC: 3659A-RN5TR

This device complies with Industry Canada

CRUISE CONTROL (if so equipped)

licence-exempt RSS standard(s). Operation is subject to the following two conditions: (1) this device may not cause interference, and (2) this device must accept any interference, including interference that may cause undesired operation of the device.

Le présent appareil est conforme aux CNR d'Industrie Canada applicables aux appareils radio exempts de licence. L'exploitation est autorisée aux deux conditions suivantes: (1) l'appareil ne doit pas produire de brouillage, et (2) l'utilisateur de l'appareil doit accepter tout brouillage radioélectrique subi, même si le brouillage est susceptible d'en compromettre le fonctionnement.

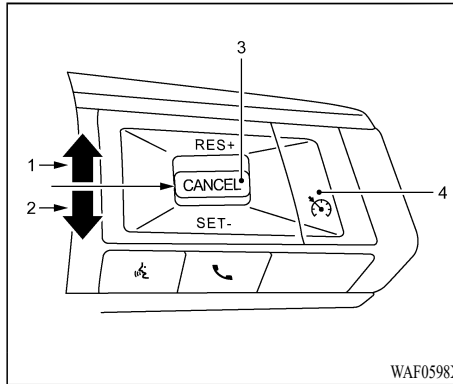

1. RES+ switch
2. SET- switch
3. CANCEL switch
4. Cruise ON/OFF switch

For models with Adaptive Cruise Control system, see “Conventional (fixed speed) cruise control mode” (P.5-87). For models with MI-PILOT Assist, see “Conventional (fixed speed) cruise control mode” (P.5-122).

WARNING

- Always observe the posted speed limits and do not set the speed over them.

- Do not use the cruise control when driving under the following conditions. Doing so could cause a loss of vehicle control and result in an accident.
 - When it is not possible to keep the vehicle at a constant speed
 - When driving in heavy traffic
 - When driving in traffic that varies speed
 - When driving in windy areas
 - When driving on winding or hilly roads
 - When driving on slippery (rain, snow, ice, etc.) roads

PRECAUTIONS ON CRUISE CONTROL

- If the cruise control system malfunctions, it will cancel automatically. The CRUISE indicator in the multi-information display will then blink to warn the driver.
- If the CRUISE indicator blinks, turn the Cruise ON/OFF switch off and have the system checked. It is recommended that you visit an authorized Mitsubishi Motors dealer for this service.

Starting and driving 5-69

- The CRUISE indicator may blink when the Cruise ON/OFF switch is turned ON while pushing up the RES+, pushing down the SET-, or pushing the CANCEL switch. To properly set the cruise control system, perform the following procedures.

CRUISE CONTROL OPERATIONS

The cruise control allows driving at speeds above 25 MPH (40 km/h) without keeping your foot on the accelerator pedal.

The cruise control will automatically be canceled if the vehicle slows down more than approximately 8 MPH (13 km/h) below the set speed.

Moving the shift lever to the N (Neutral) position will cancel the cruise control.

Turning on cruise control

Push the Cruise ON/OFF switch. The CRUISE indicator will appear.

Setting cruising speed

1. Accelerate to the desired speed.
2. Push the SET- switch down and release it.
3. Take your foot off the accelerator pedal. The vehicle will maintain the set speed.

NOTE:

If pushed the RES+ switch and released it when there is no set speed, the set speed is set to the current speed.

Passing another vehicle:

Depress the accelerator pedal to accelerate. After releasing the accelerator pedal, the vehicle will return to the previously set speed.

The vehicle may not maintain the set speed when going up or down steep hills. In such cases, drive without the cruise control.

Resetting to slower speed:

Use any one of the following methods to reset to a slower speed.

- Lightly tap the foot brake pedal. When the vehicle reaches the desired speed, push down and release the SET- switch.
- Push down and hold the SET- switch. When the vehicle reaches the desired speed, release the SET- switch.
- Quickly push down and release the SET- switch. This will reduce the vehicle speed by about 1 MPH (1.6 km/h).

Resetting to faster speed:

Use any one of the following methods to reset to a faster speed.

- Depress the accelerator pedal. When the vehicle reaches the desired speed, push down and release the SET- switch.
- Push up and hold the RES+ switch. When the vehicle reaches the desired speed, release the RES+ switch.
- Quickly push up and release the RES+ switch. This will increase the vehicle speed by about 1 MPH (1.6 km/h).

Resuming at preset speed:

Push up and release the RES+ switch.

The vehicle will resume the last set cruising speed when the vehicle speed is over 25 MPH (40 km/h).

Cancelling cruising speed

Use any one of the following methods to cancel the set speed.

- Push the CANCEL switch.
- Tap the foot brake pedal.
- Push the Cruise ON/OFF switch. The CRUISE indicator will turn off.

ADAPTIVE CRUISE CONTROL SYSTEM (ACC) (if so equipped)

WARNING

Failure to follow the warnings and instructions for proper use of the ACC system could result in serious injury or death.

- The ACC system is only an aid to assist the driver and is not a collision warning or avoidance device. It is recommended for highway use only and it is not intended for city driving. It is the driver's responsibility to stay alert, drive safely, and be in control of the vehicle at all times.
- There are limitations to the ACC system capability. The ACC system does not function in all driving, traffic, weather, and road conditions. It is the driver's responsibility to stay alert, drive safely, keep the vehicle in the traveling lane, and be in control of the vehicle at all times.
- Always observe posted speed limits and do not set the speed over them.
- The ACC system does not react to stationary and slow moving vehicles.
- Always drive carefully and attentively when using the ACC system. Read and understand the Owner's Manual thoroughly before using the ACC system. To avoid serious injury or death, do not rely on the system to prevent accidents or to control the vehicle's speed in emergency situations. Do not use the ACC system

except in appropriate road and traffic conditions.

NOTE:

For vehicles equipped with MI-PILOT Assist, refer to "MI-PILOT Assist" (P.5-90).

The ACC system maintains a selected distance from the vehicle in front of you within the speed range of 0 to 90 MPH (0 to 144 km/h) up to the set speed. The set speed can be selected by the driver between 20 to 90 MPH (30 to 144 km/h).

The vehicle travels at a set speed when the road ahead is clear.

The ACC system can be set to one of two cruise control modes.

- **Vehicle-to-vehicle distance control mode:**
For maintaining a selected distance between your vehicle and the vehicle in front of you up to the preset speed.
- **Conventional (fixed speed) cruise control mode:**
For cruising at a preset speed.

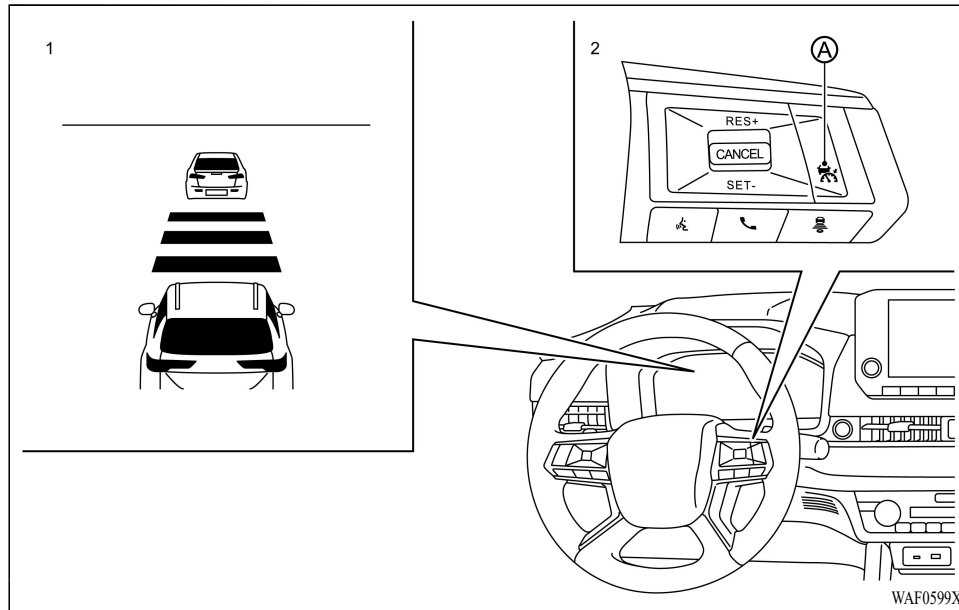

Example

1. Displays and indicators
 2. ACC switches
- Ⓐ MAIN (ON·OFF) switch

Push the MAIN switch Ⓐ to choose the cruise control mode between the vehicle-to-vehicle distance control mode and the conventional (fixed speed) cruise control mode.

Once a control mode is activated, it cannot be changed to the other cruise control mode. To change the mode, push the MAIN switch Ⓐ once to turn the system off. Then push the MAIN switch Ⓐ again to turn the system back on and select the desired cruise control mode.

Always confirm the setting in the ACC system

display.

For the vehicle-to-vehicle distance control mode, see “Vehicle-to-vehicle distance control mode” (P.5-73).

For the conventional (fixed speed) cruise control mode, see “Conventional (fixed speed) cruise control mode” (P.5-87).

5-72 Starting and driving

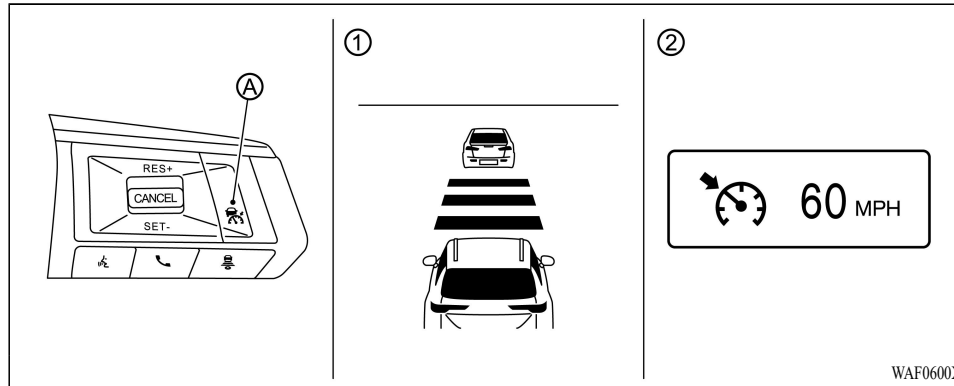

WAF0600X

Example**HOW TO SELECT THE CRUISE CONTROL MODE****Selecting vehicle-to-vehicle distance control mode**

To choose the vehicle-to-vehicle distance control mode ①, quickly push and release the MAIN switch ④.

Selecting the conventional (fixed speed) cruise control mode

To choose the conventional (fixed speed) cruise control mode ②, push and hold the MAIN switch ④ for longer than approximately 1.5

seconds. See “Conventional (fixed speed) cruise control mode” (P.5-87).

VEHICLE-TO-VEHICLE DISTANCE CONTROL MODE

In the vehicle-to-vehicle distance control mode, the ACC system automatically maintains a selected distance from the vehicle traveling in front of you according to that vehicle’s speed (up to the set speed), or at the set speed when the road ahead is clear.

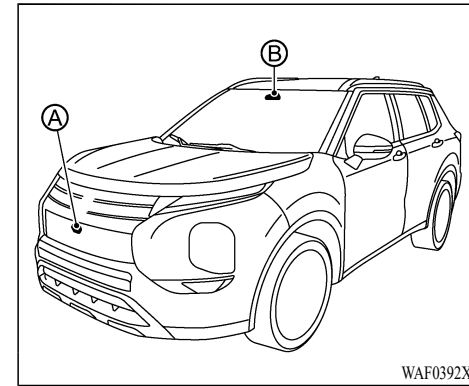

WAF0392X

The ACC system is intended to enhance the operation of the vehicle when following a vehicle traveling in the same lane and direction.

The system uses a multisensing front camera ⑥ installed behind the windshield and a radar sensor ④ located on the front of the vehicle to measure the distance to the vehicle ahead in the same lane. If the vehicle detects a slower moving vehicle ahead, the system will reduce the vehicle speed so that your vehicle follows the vehicle in front at the selected distance.

NOTE:

It is important to ensure the front camera and radar sensors are clear at all times. (See “ACC sensor maintenance” (P.5-86).)

Starting and driving 5-73

Vehicle-to-vehicle distance control mode operation

The vehicle-to-vehicle distance control mode is designed to maintain a selected distance and reduce the speed to match the slower vehicle ahead; the system will decelerate the vehicle as necessary and if the vehicle ahead comes to a stop, the vehicle decelerates to a standstill. However, the ACC system can only apply up to approximately 40% of the vehicle's total braking power. This system should only be used when traffic conditions allow vehicle speeds to remain fairly constant or when vehicle speeds change gradually. If a vehicle moves into the traveling lane ahead or if a vehicle traveling ahead rapidly decelerates, the distance between vehicles may become closer because the ACC system cannot decelerate the vehicle quickly enough. If this occurs, the ACC system will sound a warning chime and blink the system display to notify the driver to take necessary action.

The system will cancel and a warning chime will sound if the speed is below approximately 15 MPH (24 km/h) and a vehicle is not detected ahead.

See "Approach warning" (P.5-80).

The following items are controlled in the vehicle-to-vehicle distance control mode:

- When there are no vehicles traveling ahead, the vehicle-to-vehicle distance control mode maintains the speed set by the driver. The set speed range is between approximately 20 and 90 MPH (30 and 144 km/h).
- When there is a vehicle traveling ahead, the vehicle-to-vehicle distance control mode adjusts the speed to maintain the distance, selected by driver, from the vehicle ahead. The adjusting speed range is up to the set speed. If the vehicle ahead comes to a stop, the vehicle decelerates to a standstill within the limitations of the system. The system will cancel once it judges a standstill with a warning chime.
- When the vehicle traveling ahead has moved out from its lane of travel, the vehicle-to-vehicle distance control mode accelerates and maintains vehicle speed up to the set speed.

The ACC system does not control vehicle speed or warn you when you approach stationary and slow moving vehicles. You must pay attention to vehicle operation to maintain proper distance from vehicles ahead when approaching toll gates or traffic congestion.

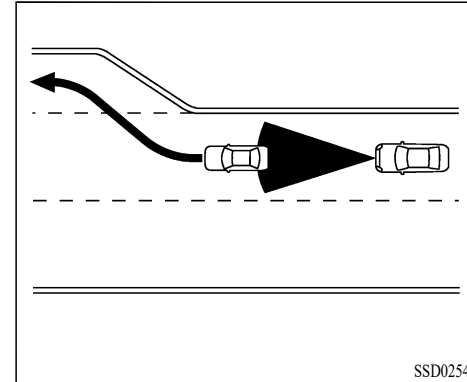

When driving on the highway at a set speed and approaching a slower traveling vehicle ahead, the ACC system will adjust the speed to maintain the distance, selected by the driver, from the vehicle ahead. If the vehicle ahead changes lanes or exits the freeway, the ACC system will accelerate and maintain the speed up to the set speed. Pay attention to the driving operation to maintain control of the vehicle as it accelerates to the set speed.

The vehicle may not maintain the set speed on winding or hilly roads. If this occurs, you will have to manually control the vehicle speed.

Normally when controlling the distance to a vehicle ahead, this system automatically accelerates or decelerates your vehicle according to

5-74 Starting and driving

the speed of the vehicle ahead. Depress the accelerator to properly accelerate your vehicle when acceleration is required for a lane change. Depress the brake pedal when deceleration is required to maintain a safe distance to the vehicle ahead due to its sudden braking or if a vehicle cuts in. Always stay alert when using the ACC system.

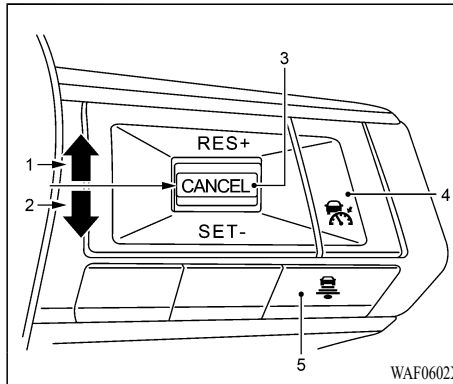

set speed.

4. **MAIN** switch:
Master switch to activate the system.
5. **DISTANCE** switch:
Changes the vehicle's following distance:
 - Long
 - Middle
 - Short

Vehicle-to-vehicle distance control mode switches

The system is operated by a MAIN switch and four control switches, all mounted on the steering wheel.

1. **RES+** switch:
Resumes set speed or increases speed incrementally.
2. **SET-** switch:
Sets desired cruise speed, reduces speed incrementally.
3. **CANCEL** switch:
Deactivates the system without erasing the

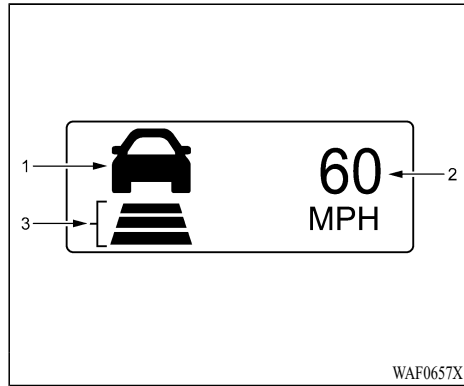

Example

Vehicle-to-vehicle distance control mode display and indicators

1. Vehicle ahead detection indicator:
Indicates whether it detects a vehicle in front of you.
2. Set vehicle speed indicator:
Indicates the set vehicle speed.
The unit of the speed may vary depending on the country.
3. Set distance indicator:
Displays the selected distance between vehicles set with the DISTANCE switch.

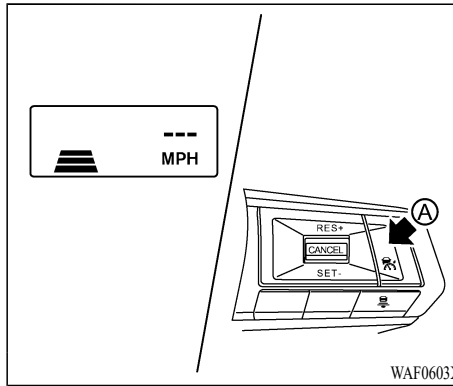

Operating vehicle-to-vehicle distance control mode

To turn on the cruise control, quickly push and release the MAIN switch **A** on. The set distance indicator and set vehicle speed indicator come on and in a standby state for setting.

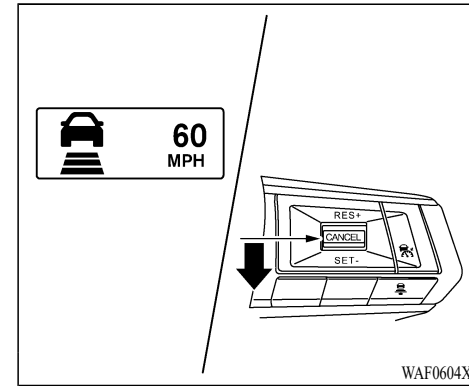

To set cruising speed, accelerate your vehicle to the desired speed, push the SET- switch and release it. (The vehicle ahead detection indicator, set distance indicator and set vehicle speed indicator come on.) Take your foot off the accelerator pedal. Your vehicle will maintain the set speed.

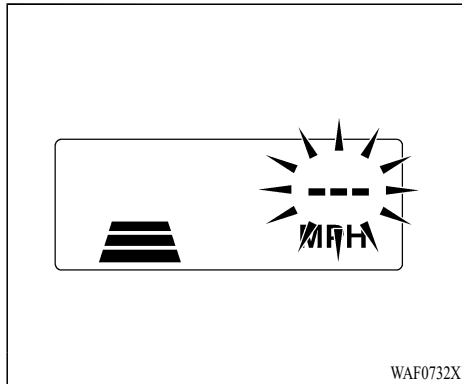

- When the SNOW mode, MUD mode (AWC models) or GRAVEL mode is selected.
- When a wheel is slipping.

When the SET- switch is pushed down under the following conditions, the ACC Assist system cannot be set and the set vehicle speed indicator blinks for approximately 2 seconds.

- When traveling below 20 MPH (30 km/h) and the vehicle ahead is not detected.
- When the shift lever is not in the D (Drive) position or the manual shift mode.
- When the parking brake is applied.
- When the brakes are operated by the driver.
- When the ASC system is off. For additional information, see “Active stability control (ASC)” (P.5-159).
- When the ASC system (including the traction control system) is operating.

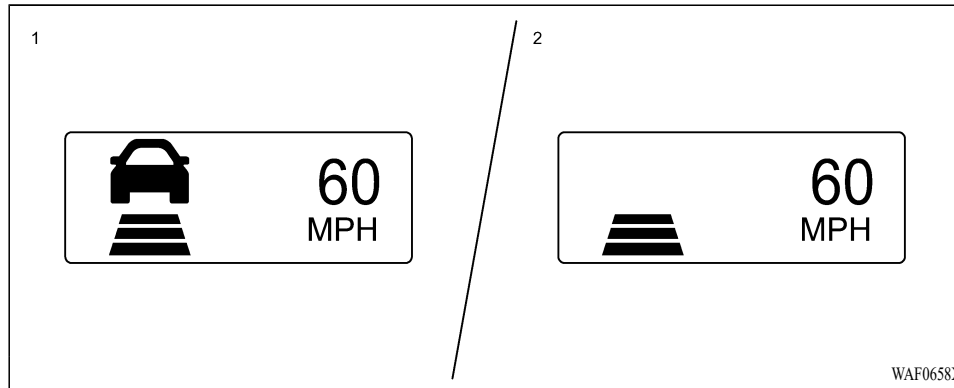

1. System set display with vehicle ahead*
2. System set display without vehicle ahead*

The driver sets the desired vehicle speed based on the road conditions. The ACC system maintains the set vehicle speed, similar to standard cruise control, as long as no vehicle is detected in the lane ahead.

The ACC system displays the set speed.

Vehicle detected ahead:

When a vehicle is detected in the lane ahead, the ACC system decelerates the vehicle by controlling the throttle and applying the brakes to match the speed of a slower vehicle ahead. The system then controls the vehicle speed based on the speed of the vehicle ahead to maintain the

driver selected distance.

NOTE:

- **The stop lights of the vehicle come on when braking is performed by the ACC system.**
- **When the brake operates, a noise may be heard and/or vibration may be felt. This is not a malfunction.**

When a vehicle ahead is detected, the vehicle ahead detection indicator comes on. The ACC system will also display the set speed and selected distance.

*: The design of the set display may differ depending on the model

Vehicle ahead not detected:

When a vehicle is no longer detected ahead, the ACC system gradually accelerates your vehicle to resume the previously vehicle set speed. The ACC system then maintains the vehicle set speed.

When a vehicle is no longer detected, the vehicle ahead detection indicator and speed control status indicator (maintain speed control mode) turn off.

The ACC system gradually accelerates to the vehicle set speed, but you can depress the accelerator pedal to quickly accelerate. When a vehicle is no longer detected and your vehicle is traveling under approximately 15 MPH (25 km/h), the ACC system automatically cancels.

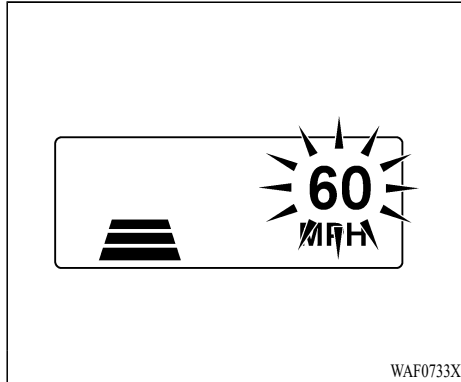

When passing another vehicle, the set speed indicator will flash when the vehicle speed exceeds the set speed. The vehicle detect indicator will turn off when the area ahead of the vehicle is open. When the pedal is released, the vehicle will return to the previously set speed.

Even though your vehicle speed is set in the ACC system, you can depress the accelerator pedal when it is necessary to accelerate your vehicle rapidly.

How to change set vehicle speed

The set vehicle speed can be adjusted.

To change to a faster cruising speed:

- Push up and hold the RES+ switch . The set vehicle speed increases in increments of 5 MPH (5 km/h).
- Push up, then quickly release the RES+ switch. Each time you do this, the set vehicle speed increases by 1 MPH (1 km/h).

To change to a slower cruising speed:

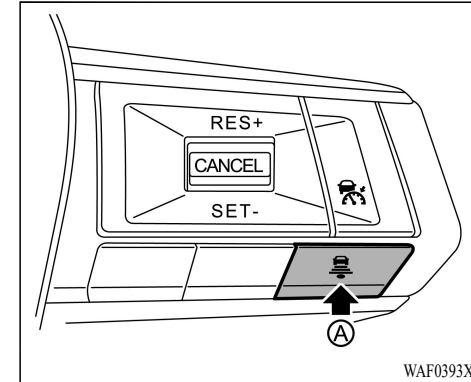

- Push down and hold the SET- switch. The set vehicle speed decreases in increments of 5 MPH (5 km/h).
- Push down, then quickly release the SET- switch. Each time you do this, the set vehicle speed decreases by 1 MPH (1 km/h).



How to change set distance to vehicle ahead

The distance to the vehicle ahead can be selected at any time depending on the traffic conditions.

Each time the DISTANCE switch ① is pushed, the set distance will change to long, middle, short and back to long again in that sequence.

Distance	Display	Approximate distance at 60 MPH (100 km/h) [ft (m)]
Long	 60 MPH	200 (60)
Middle	 60 MPH	150 (45)
Short	 60 MPH	90 (30)

WAF0659X

- The distance to the vehicle ahead will change according to the vehicle speed. The higher the vehicle speed, the longer the distance.
- The distance setting will remain at the current setting even if the engine is restarted.

Cut-in detection

If a vehicle moves into your traveling lane near your vehicle, the ACC system may inform the driver by flashing the vehicle ahead detection indicator.

Approach warning

If your vehicle comes closer to the vehicle ahead due to rapid deceleration of that vehicle or if another vehicle cuts in, the system warns the driver with the chime and ACC system display. Decelerate by depressing the brake pedal to maintain a safe vehicle distance if:

- The chime sounds.
- The vehicle ahead detection indicator and set distance indicator blink.
- You judge it necessary to maintain a safe distance.

The warning chime may not sound in some cases when there is a short distance between vehicles. Some examples are:

- When the vehicles are traveling at the same speed and the distance between vehicles is not changing
- When the vehicle ahead is traveling faster and the distance between vehicles is increasing
- When a vehicle cuts in near your vehicle

The warning chime will not sound when:

- Your vehicle approaches other vehicles that are parked or moving slowly.
- The accelerator pedal is depressed, overriding the system.

NOTE:

The approach warning chime may sound and the system display may blink when the radar sensor detects objects on the side of the vehicle or on the side of the road. This may cause the ACC system to decelerate or accelerate the vehicle. The radar sensor may detect these objects when the vehicle is driven on winding roads, narrow roads, hilly roads or when entering or exiting a curve. In these cases you will have to manually control the proper distance ahead of your vehicle.

Also, the sensor sensitivity can be affected by vehicle operation (steering maneuver or driving position in the lane) or traffic or vehicle condition (for example, if a vehicle is being driven with some damage).

Acceleration when passing

When the ACC system is engaged above 44 MPH (70 km/h) and following a slower vehicle (below the set vehicle speed), and the turn signal is activated to the left, the ACC system will automatically start to accelerate the vehicle to help initiate passing on the left and will begin to reduce the distance to vehicle directly ahead. Only the left side turn signal operates this feature. As the driver steers the vehicle and moves into the passing lane, if no vehicle is detected ahead the ACC system will continue to accelerate to the set vehicle speed. If another

vehicle is detected ahead, then the vehicle will accelerate up to the following speed of that vehicle. If the vehicle is not steered into the left lane to pass, the acceleration will stop after a short time and regain the set following distance. Acceleration can be stopped at any point by depressing the brake pedal or the CANCEL switch on the steering wheel.

WARNING

In order to reduce the risk of a collision that may result in serious injury or death, please be aware of the following:

- This function is only activated with the left turn signal and will briefly accelerate the vehicle even if a lane change is not initiated. This can include non-passing situations such as left side exits.
- Ensure that when passing another vehicle, the adjacent lane is clear before initiating the pass. Sudden changes in traffic may occur while passing. Always manually steer or brake as needed. Never solely rely on the system.

Vehicle-to-vehicle distance control mode limitations**WARNING**

Listed below are the system limitations for the ACC system. Failure to operate the vehicle in accordance with these system limitations could result in serious injury or death.

- The system is primarily intended for use on straight, dry, open roads with light traffic. It is not advisable to use the system in city traffic or congested areas.
- This system will not adapt automatically to road conditions. This system should be used in evenly flowing traffic. Do not use the system on roads with sharp curves, or on icy roads, in heavy rain or in fog.
- As there is a performance limit to the distance control function, never rely solely on the ACC system. This system does not correct careless, inattentive or absent-minded driving, or overcome poor visibility in rain, fog, or other bad weather. Decelerate the vehicle speed by depressing the brake pedal, depending on the distance to the vehicle ahead and the surrounding circumstances in order to maintain a safe distance between vehicles.
- If the vehicle ahead comes to a stop, the vehicle decelerates to a standstill within the

limitations of the system. The system will cancel once it judges that the vehicle has come to a standstill and sound a warning chime. To prevent the vehicle from moving, the driver must depress the brake pedal.

- Always pay attention to the operation of the vehicle and be ready to manually control the proper following distance. The vehicle-to-vehicle distance control mode of the ACC system may not be able to maintain the selected distance between vehicles (following distance) or selected vehicle speed under some circumstances.
- The ACC system does not detect the following objects:
 - Stationary or slow moving vehicles (when your vehicle is approaching them)
 - Pedestrians or objects in the roadway
 - Oncoming vehicles in the same lane
 - Motorcycles traveling offset in the travel lane
- The ACC system may not detect a vehicle ahead in certain road, weather or driving conditions. To avoid accidents, never use the ACC system under the following conditions:

- On roads with heavy, high-speed traffic or sharp curves
- On slippery road surfaces such as on ice or snow, etc.
- On a bumpy road surface, such as an uneven dirt road
- On steep downhill roads (the vehicle may go beyond the vehicle set speed and frequent braking may result in overheating the brakes)
- On repeated uphill and downhill roads
- During bad weather (rain, fog, snow, etc.)
- When the sensor detection is reduced (conditions such as rain, snow, fog, dust storms, sandstorms, and road spray from other vehicles)
- When dirt, ice, snow or other material adhere to the radar sensor area
- When traffic conditions make it difficult to keep a proper distance between vehicles because of frequent acceleration or deceleration

- When a complicated-shaped vehicle such as a car carrier trailer or flatbed truck/trailer is near the vehicle ahead
- When there is interference by other radar sources
- When excessively heavy baggage is loaded in the rear seat or cargo area of your vehicle
- When towing a trailer or other vehicle
- Do not use the ACC system if you are towing a trailer. The system may not detect a vehicle ahead.
- Do not use the ACC system when driving with a tire that is not within normal tire conditions (for example, tire wear, low tire pressure, installation of tire chains, non-standard wheels).
- In some road or traffic conditions, a vehicle or object can unexpectedly come into the sensor detection zone and cause automatic braking. You may need to control the distance from other vehicles using the accelerator pedal. Always stay alert and avoid using the ACC system when it is not recommended in this section.
- The ACC system also uses a multi-sensing front camera. The following are some conditions in which the camera may not

properly detect a vehicle and detection of a vehicle ahead may be delayed:

- Poor visibility (conditions such as rain, snow, fog, dust storms, sandstorms, and road spray from other vehicles)
- The camera area of the windshield is fogged up or covered with dirt, water drops, ice, snow, etc.
- Strong light (for example, sunlight or high beams from oncoming vehicles) enters the front camera
- A sudden change in brightness occurs (for example, when the vehicle enters or exits a tunnel or shaded area or lightning flashes)

The ACC system is designed to automatically check the radar sensor's operation within the limitations of the system.

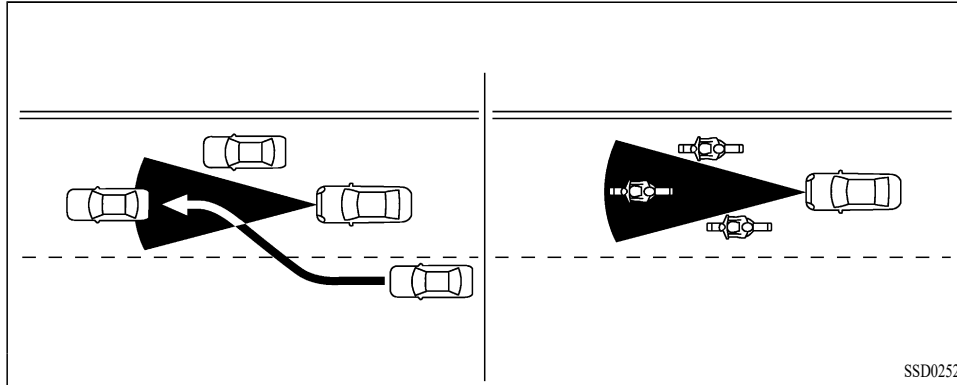

The detection zone of the ACC sensor is limited. A vehicle ahead must be in the detection zone for the vehicle-to-vehicle distance detection mode to maintain the selected distance from the vehicle ahead.

A vehicle ahead may move outside of the detection zone due to its position within the same lane of travel. Motorcycles may not be detected in the same lane ahead if they are traveling offset from the centerline of the lane. A vehicle that is entering the lane ahead may not be detected until the vehicle has completely moved into the lane. **If this occurs, the ACC system may warn you by blinking the system indicator and sounding the chime. The driver may have to manually control the proper**

distance away from vehicle traveling ahead.

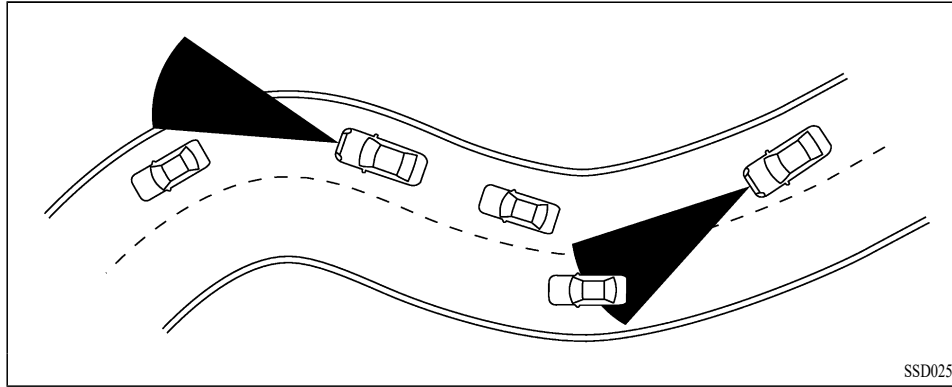

SSD0253

When driving on some roads, such as winding, hilly, curved, narrow roads, or roads which are under construction, the ACC sensor may detect vehicles in a different lane, or may temporarily not detect a vehicle traveling ahead. This may cause the ACC system to decelerate or accelerate the vehicle.

The detection of vehicles may also be affected by vehicle operation (steering maneuver or traveling position in the lane, etc.) or vehicle condition. **If this occurs, the ACC system may warn you by blinking the system indicator and sounding the chime unexpectedly. You will have to manually control the proper distance away from the vehicle traveling ahead.**

System temporarily unavailable

Condition A:

Under the following conditions, the ACC system is automatically canceled. A chime will sound and the system will not be able to be set.

- The vehicle ahead is not detected and your vehicle is traveling below the speed of 15 MPH (24 km/h).
- When the system judges the vehicle is at standstill.
- The shift lever is not in the D (Drive) position or manual shift mode.
- The electronic parking brake is applied.

- The ASC turned off.
- The AEB applies harder braking.
- ASC (including the traction control system) operates.
- The SNOW mode, MUD mode (AWC models) or GRAVEL mode is selected.
- A wheel slips.
- When distance measurement becomes impaired due to adhesion of dirt or obstruction to the sensor.
- When the radar signal is temporarily interrupted.

Action to take:

When the conditions listed above are no longer present, turn the system off using the MAIN switch. Turn the ACC system back on to use the system.

Condition B:

When there is inclement weather (rain, fog, snow, etc.) blocking the front radar sensor, the ACC system will automatically be canceled, the chime will sound and the “Forward Driving Aids Temporarily Disabled Front Sensor Blocked” warning message will appear in the multi-information display.

Action to take:

When the above condition is no longer present, the warning message will no longer be available in the multi-information display and the system will operate normally. If the “Forward Driving Aids Temporarily Disabled Front Sensor Blocked” warning message continues to be displayed, have the system checked. It is recommended that you visit an authorized Mitsubishi Motors dealer for this service.

Condition C:

When the radar sensor on the vehicle front area is covered with dirt or is obstructed, the ACC system will automatically be canceled.

The chime will sound and the “Forward Driving Aids Temporarily Disabled Front Sensor Blocked” warning message will appear in the multi-information display.

Action to take:

If the warning message appears, stop the vehicle in a safe place, push the park button to shift to the P (Park) position, and turn the engine off. When the radar signal is temporarily interrupted, clean the sensor area on the vehicle front area and restart the engine. If the “Forward Driving Aids Temporarily Disabled Front Sensor Blocked” warning message continues to be displayed, check that the cover of the sensor is not covered by dirt, snow or ice. If the

warning message is still displayed, have the system checked. It is recommended that you visit an authorized Mitsubishi Motors dealer for this service.

Condition D:

When driving on roads with limited road structures or buildings (for example, long bridges, deserts, snow fields, driving next to long walls), the system may illuminate the system warning light and display the “Forward Driving Aids Temporarily Disabled Front Sensor Blocked” message.

Action to take:

When the above driving conditions no longer exist, turn the system back on.

ACC system malfunction

If the ACC system malfunctions, it will be turned off automatically, a chime will sound, and the speed control status warning (orange) will illuminate.

Action to take:

If the warning illuminates, stop the vehicle in a safe place. Turn the engine off, restart the engine and set the ACC system again. If it is not possible to set the ACC system or the warning stays on, it may be a malfunction. Although the normal driving can be continued, the ACC system should be inspected. It is recommended

that you visit an authorized Mitsubishi Motors dealer for this service.

NOTE:

If the ACC system is temporarily unavailable, the conventional cruise control mode may still be used. For additional information, see “Conventional (fixed speed) cruise control mode” (P.5-87).

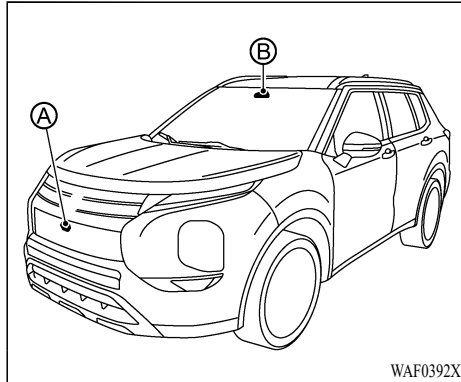

ACC sensor maintenance

The radar sensor ① is located on the front of the vehicle.

To keep the ACC system operating properly, be sure to observe the following:

- Always keep the sensor area clean.
- Do not strike or damage the areas around the sensor.
- Do not attach a sticker (including transparent material) or install an accessory near the sensor. This could cause failure or malfunction.
- Do not attach metallic objects near the sensor area (brush guard, etc.). This could

cause failure or malfunction.

- Do not alter, remove, or paint the exterior of the vehicle front area.

Before customizing or restoring the exterior of the vehicle front area, it is recommended that you visit an authorized Mitsubishi Motors dealer.

The camera sensor ② is located above the inside mirror.

To keep the proper operation of the systems and prevent a system malfunction, be sure to observe the following:

- Always keep the windshield clean.
- Do not attach a sticker (including transparent material) or install an accessory near the camera unit.
- Do not place reflective materials, such as white paper or a mirror, on the instrument panel. The reflection of sunlight may adversely affect the camera unit's capability of detecting the lane markers.
- Do not strike or damage the areas around the camera unit. Do not touch the camera lens or remove the screw located on the camera unit.

If the camera unit is damaged due to an accident, it is recommended that you visit an authorized Mitsubishi Motors dealer.

Radio frequency statement:

For USA

Type approval number:

FCC ID: NF3-FR5CPEC

User Manual statement according to §15.19:

This device complies with Part 15 of the FCC Rules.

Operation is subject to the following two conditions:

1. this device may not cause harmful interference, and
2. this device must accept any interference received, including interference that may cause undesired operation.

User Manual statement according to §15.21:

Changes or modifications made to this equipment not expressly approved by Robert BOSCH GmbH may void the FCC authorization to operate this equipment.

User Manual statement according to §15.105:

This equipment has been tested and found to comply with the limits for a Class A digital device, pursuant to Part 15 of the FCC Rules. These limits are designed to provide reasonable protection against harmful interference when the equipment is operated in a commercial environment. This equipment generates, uses,

and can radiate radio frequency energy and, if not installed and used in accordance with the instruction manual, may cause harmful interference to radio communications. Operation of this equipment in a residential area is likely to cause harmful interference in which case the user will be required to correct the interference at his own expense.

RF Exposure Information according 2.1091/2.1093/OET bulletin 65:

Radiofrequency radiation exposure information:

This equipment complies with FCC radiation exposure limits set forth for an uncontrolled environment. This equipment should be installed and operated with minimum distance of 20 cm between the radiator and your body.

The transmitter must not be co-located or operating in conjunction with any other antenna or transmitter.

For Canada

Type approval number:

IC: 3387A-FR5CPEC

Legal warning for RF equipment:

This device complies with Industry Canada licence-exempt RSS standard(s). Operation is subject to the following two conditions: (1) this device may not cause interference, and (2) this device must accept any interference, including interference that may cause undesired operation

of the device.

Le présent appareil est conforme aux CNR d'Industrie Canada applicables aux appareils radio exempts de licence. L'exploitation est autorisée aux deux conditions suivantes: (1) l'appareil ne doit pas produire de brouillage, et (2) l'utilisateur de l'appareil doit accepter tout brouillage radioélectrique subi, même si le brouillage est susceptible d'en compromettre le fonctionnement.

CONVENTIONAL (fixed speed) CRUISE CONTROL MODE

WARNING

ACC provides no approach warnings or automatic braking in the conventional (fixed speed) cruise control mode.

This mode allows driving at a speed between 20 to 90 MPH (30 to 144 km/h) without keeping your foot on the accelerator pedal.

WARNING

- In the conventional (fixed speed) cruise control mode, a warning chime does not sound to warn you if you are too close to the vehicle ahead, as neither the presence

of the vehicle ahead nor the vehicle-to-vehicle distance is detected.

- Pay special attention to the distance between your vehicle and the vehicle ahead of you or a collision could occur.
- Always confirm the setting in the ACC system display.
- Do not use the conventional (fixed speed) cruise control mode when driving under the following conditions:
 - When it is not possible to keep the vehicle at a set speed
 - In heavy traffic or in traffic that varies in speed
 - On winding or hilly roads
 - On slippery roads (rain, snow, ice, etc.)
 - In very windy areas
- Doing so could cause a loss of vehicle control and result in an accident.

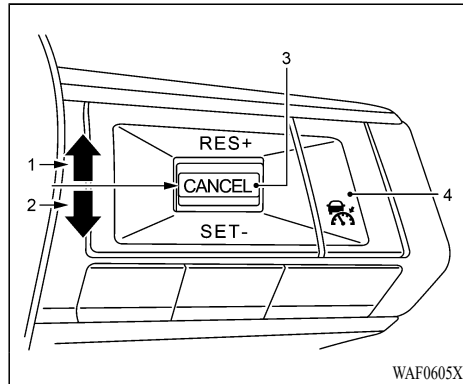

Conventional (fixed speed) cruise control switch

1. **RES+** switch:
Resumes set speed or increases speed incrementally.
2. **SET-** switch:
Sets the desired cruise speed, reduces speed incrementally.
3. **CANCEL** switch:
Deactivates the system without erasing the set speed.
4. **MAIN** switch:
Master switch to activate the system.

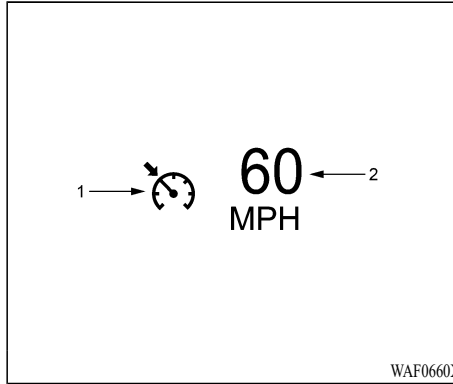

Conventional (fixed speed) cruise control mode display and indicators

The display is located in the multi-information display.

1. Cruise indicator:
This indicator indicates the condition of the ACC system depending on a color.
 - Cruise control ON indicator (gray):
Indicates that the ACC switch is on
 - Cruise control SET indicator (green):
Indicates that the cruising speed is set
 - Cruise control warning (orange):
Indicates that there is a malfunction in the ACC system

2. Set vehicle speed indicator:

This indicator indicates the set vehicle speed.

For Canadian models, the speed is displayed in km/h.

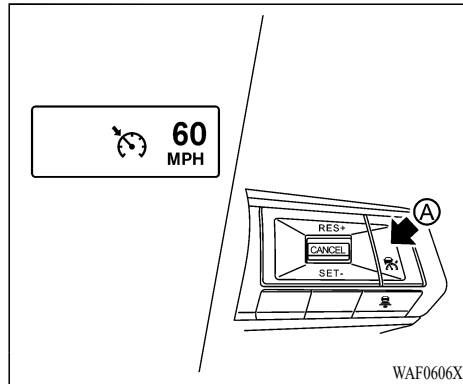

Operating conventional (fixed speed) cruise control mode

To turn on the conventional (fixed speed) cruise control mode, push and hold the MAIN switch **A** for longer than about 1.5 seconds.

When pushing the MAIN switch on, the conventional (fixed speed) cruise control mode display and indicators are displayed in the multi-information display. After you hold the MAIN switch on for longer than about 1.5 seconds, the ACC system display turns off. The cruise indicator appears. You can now set your desired cruising speed. Pushing the MAIN switch again will turn the system completely off. When the ignition switch is placed in the

OFF position, the system is also automatically turned off.

To use the ACC system again, quickly push and release the MAIN switch (vehicle-to-vehicle distance control mode) or push and hold it (conventional cruise control mode) again to turn it on.

WARNING

To avoid accidentally engaging cruise control, make sure to turn the MAIN switch off when not using the ACC system.

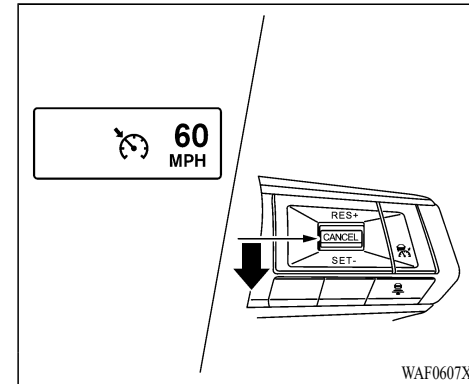

To set cruising speed, accelerate your vehicle to the desired speed, push down the SET— switch and release it. (The color of the cruise indicator changes to green and set vehicle speed indicator comes on.) Take your foot off the accelerator pedal. Your vehicle will maintain the set speed.

- To pass another vehicle, depress the accelerator pedal. When you release the pedal, the vehicle will return to the previously set speed.
- The vehicle may not maintain the set speed when going up or down steep hills. If this happens, manually maintain vehicle speed.

To cancel the preset vehicle speed, use any of the following methods:

1. Push the CANCEL switch. The set vehicle speed indicator will turn off.
2. Tap the brake pedal. The set vehicle speed indicator will turn off.
3. Turn the MAIN switch off. Both the cruise indicator and set vehicle speed indicator will turn off.

To reset at a faster cruising speed, use one of the following three methods:

1. Depress the accelerator pedal. When the vehicle attains the desired speed, push down and release the SET- switch.
2. Push up and hold the RES+ switch. When the vehicle attains the desired speed, release the switch.
3. Push up, then quickly release the RES+ switch. Each time you do this, the set vehicle speed will increase by about 1 MPH (1 km/h).

To reset at a slower cruising speed, use one of the following three methods:

1. Lightly tap the brake pedal. When the vehicle attains the desired speed, push down the SET— switch and release it.
2. Push down and hold the SET- switch. Release the switch when the vehicle slows down to the desired speed.

3. Push down, then quickly release the SET— switch. Each time you do this, the set vehicle speed will decrease by about 1 MPH (1 km/h).

To resume the preset vehicle speed, push up and release the RES+ switch. The vehicle will resume the last set cruising speed when the vehicle speed is over 20 MPH (30 km/h).

MI-PILOT ASSIST (if so equipped)

This section contains the information about the following system features:

- MI-PILOT Assist (general system operation)
- MI-PILOT Assist with Navi-link (additional functionality, if so equipped)

WARNING

Failure to follow the warnings and instructions for proper use of the MI-PILOT Assist system could result in serious injury or death.

- **MI-PILOT Assist is not a self-driving system. Within the limits of its capabilities, as described in this manual, it helps the driver with certain driving activities.**
- **The MI-PILOT Assist system is not a replacement for proper driving procedures and is not designed to correct careless, inattentive or absent-minded driving. MI-PILOT Assist will not always steer the vehicle to keep it in the lane. The MI-PILOT Assist system is not designed to prevent loss of control. It is the driver's responsibility to stay alert, drive safely, keep the vehicle in the traveling lane, and be in control of the vehicle at all times.**
- **There are limitations to the MI-PILOT Assist system capability. The MI-PILOT Assist system does not function in all driving, traffic, weather, and road condi-**

tions. It is the driver's responsibility to stay alert, drive safely, keep the vehicle in the traveling lane, and be in control of the vehicle at all times.

- The MI-PILOT Assist system is only an aid to assist the driver and is not a collision warning or avoidance device.
- The MI-PILOT Assist system is for highway use only and is not intended for city driving. Failure to apply the brakes or steer the vehicle when necessary may result in a serious accident.
- Always observe posted speed limits and do not set the speed over them.
- Never take your hands off the steering wheel when driving. Always keep your hands on the steering wheel and drive your vehicle safely.
- Never unfasten your safety belt when using MI-PILOT Assist. Doing so automatically cancels the MI-PILOT Assist system.
- The MI-PILOT Assist system does not react when approaching stationary and slow moving vehicles.
- Always drive carefully and attentively when using the MI-PILOT Assist system. Read and understand the Owner's Manual thoroughly before using the MI-PILOT Assist system. To avoid serious injury or death, do not rely on the system to prevent accidents or to control the vehicle's speed in emergency situations. Do not use the

MI-PILOT Assist system except in appropriate road and traffic conditions.

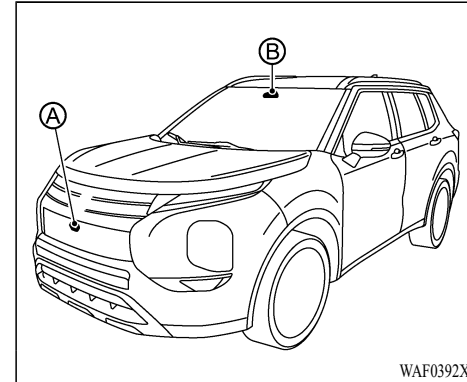

The MI-PILOT Assist system is intended to enhance the operation of the vehicle when following a vehicle traveling in the same lane and direction.

The MI-PILOT Assist system uses a multi-sensing front camera (B) installed behind the windshield to monitor the lane markers and a radar sensor (A) located on the front of the vehicle to measure the distance to the vehicle ahead in the same lane. If the system detects a slower moving vehicle ahead, the system will reduce the vehicle speed so that your vehicle follows the vehicle in front at the selected distance. The system will also help keep the vehicle centered in the traveling lane when clear lane markings are detected.

Starting and driving 5-91

NOTE:

It is important to ensure the front camera and radar sensors are clear at all times. (See “ACC sensor maintenance” (P.5-116) and “Lane Keep Assist (LKA) maintenance” (P.5-122) for more details.)

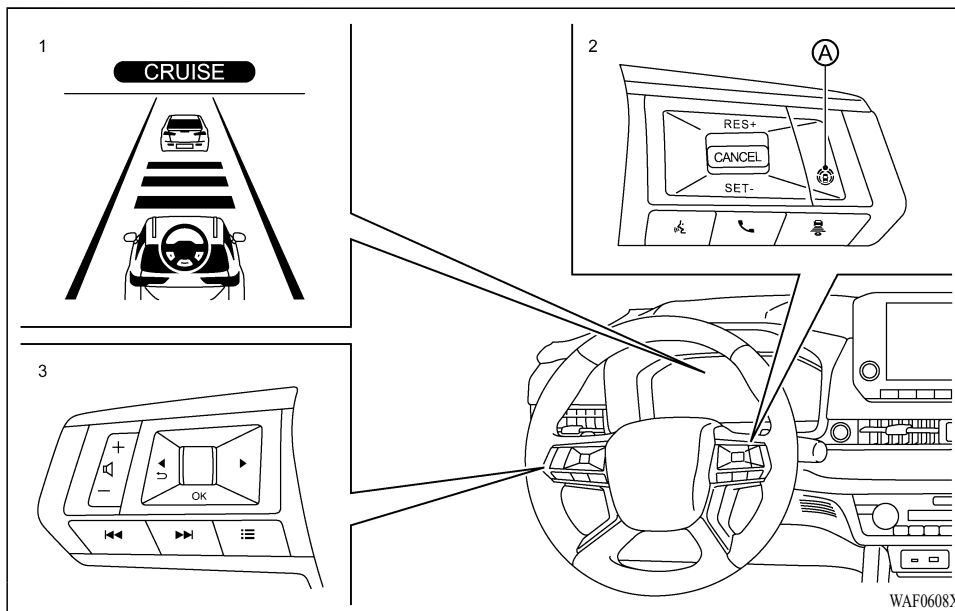

1. Multi-information display
 2. Steering wheel remote control switches (right side)
 3. Steering wheel remote control switches (left side)
- Ⓐ MI-PILOT Assist switch

MI-PILOT ASSIST SYSTEM OPERATION

The MI-PILOT Assist system has the following two functions:

1. Adaptive Cruise Control (ACC)

The ACC system can be set to one of two cruise control modes:

- Conventional (fixed speed) cruise control mode:

For cruising at a preset vehicle speed

For additional information, see “Turning the conventional (fixed speed) cruise control mode ON” (P.5-97).

NOTE:

Lane Keep Assist (LKA) is not available in the conventional (fixed speed) cruise control mode.

- Vehicle-to-vehicle distance control mode:
The ACC system maintains a selected distance from the vehicle in front of you within the speed range of 0 to 90 MPH (0 to 144 km/h) up to the vehicle set speed. The vehicle set speed can be selected by the driver between 20 to 90 MPH (30 to 144 km/h). When the vehicle ahead slows to a stop, your vehicle gradually decelerates to a standstill. When the vehicle is stopped, the ACC system maintains braking force to keep your vehicle stopped.
- When your vehicle is stopped for less than approximately 3 seconds and the vehicle ahead begins to move, your vehicle will start moving again automatically.

- When your vehicle is at a standstill for more than approximately 3 seconds and the vehicle ahead begins to accelerate, push up the RES+ switch or lightly depress the accelerator pedal. The ACC system starts to follow the vehicle ahead.
- Always check surroundings before restarting the vehicle.
- For vehicles equipped with MI-PILOT Assist with Navi-link and only when on a limited access freeway (as identified in the navigation map data):
 - The time the vehicle can remain stopped and automatically restart is extended from 3 seconds to 30 seconds.
 - If a vehicle ahead cuts in or out of the lane ahead, the vehicle may not automatically start when the traffic ahead begins to move. You need to push up the RES+ switch or lightly depress the accelerator pedal to follow the vehicle directly ahead when it is safe to do so.
- When no vehicle is detected ahead within the driver selected distance, the vehicle travels at the speed set by the driver. The speed must be above 20 MPH (30 km/h) to use this function.

NOTE:

Even if the Automatic Emergency Braking (AEB) setting is turned off by the driver using the “Settings” menu in the multi-information display, AEB will be automatically turned on when ACC is used.

2. Lane Keep Assist (LKA)

The Lane Keep Assist (LKA) function controls the steering system to help keep your vehicle within the traveling lane.

When there is no vehicle ahead, Lane Keep Assist (LKA) is not available at speeds under 37 MPH (60 km/h).

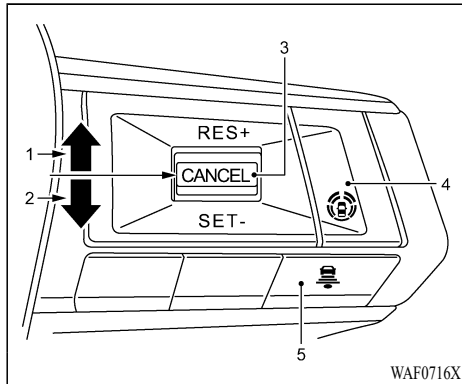

- Long
- Middle
- Short

NOTE:

For MI-PILOT Assist with Navi-link equipped vehicles: When the Manual mode is selected in the “Spd. Limit Assist” menu on the multi-information display, operating the RES+ or SET- switch can apply the indicated speed limit sign to the set vehicle speed. (See “Speed Limit Assist - a feature of MI-PILOT Assist with Navi-link” (P.5-108).)

MI-PILOT ASSIST SWITCHES

1. RES+ switch:
Resumes set vehicle speed or increases speed incrementally
2. SET- switch:
Sets desired cruise speed or reduces speed incrementally
3. CANCEL switch:
Deactivates the MI-PILOT Assist system
4. MI-PILOT Assist switch:
Turns the MI-PILOT Assist system on or off
5. DISTANCE switch:

5-94 Starting and driving

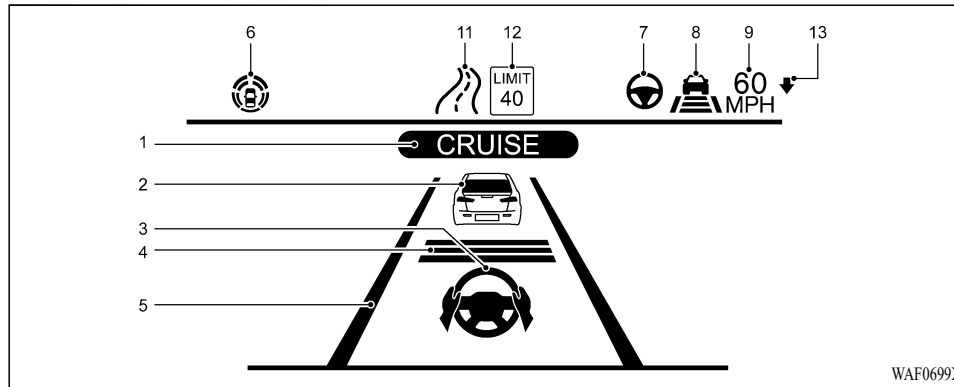

Models with type 1 display

WAF0699X

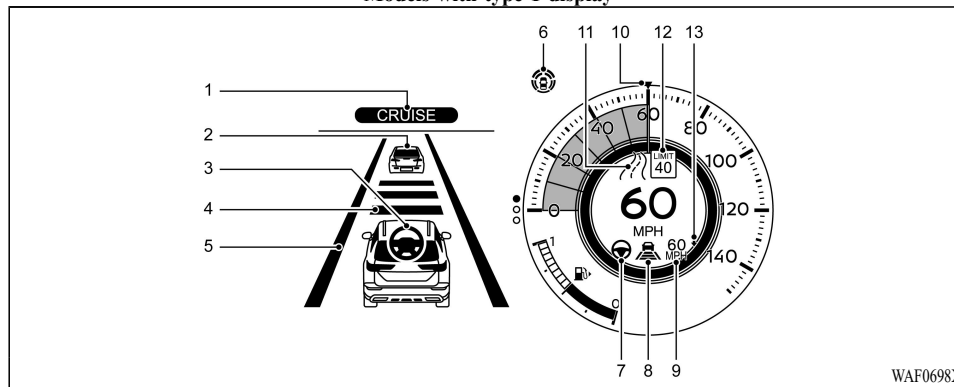

Models with type 2 display

WAF0698X

MI-PILOT ASSIST SYSTEM DISPLAY AND INDICATORS

1. MI-PILOT Assist activation

Displays once the MI-PILOT Assist system is activated

2. Vehicle ahead detection indicator

Indicates whether the system detects a vehicle in front of you

3. Lane Keep Assist (LKA) indicator

Indicates the status of the Lane Keep Assist (LKA) function by the color of the indicator

- Lane Keep Assist (LKA) indicator (gray): Lane Keep Assist (LKA) standby
- Lane Keep Assist (LKA) indicator (green): Lane Keep Assist (LKA) active

4. Set distance indicator



Displays the selected distance

5. Lane marker indicator



Indicates whether the system detects lane markers

- No lane markers displayed: Lane Keep Assist (LKA) is turned off
- Lane marker indicator (gray): No lane markers detected
- Lane marker indicator (green): Lane markers detected, Lane Keep Assist (LKA) is active

Starting and driving 5-95

- Lane marker indicator (orange): Lane departure is detected
6. **MI-PILOT Assist status indicator** ()
Indicates the status of the MI-PILOT Assist system by the color of the indicator
- MI-PILOT Assist status indicator (white): MI-PILOT Assist is on but in standby
 - MI-PILOT Assist status indicator (green): MI-PILOT Assist active
7. **Lane Keep Assist (LKA) status indicator/warning** ()
Displays the status of the Lane Keep Assist (LKA) by the color of the indicator/warning
- No Lane Keep Assist (LKA) status indicator displayed: Lane Keep Assist (LKA) is turned off
 - Lane Keep Assist (LKA) status indicator (gray): Lane Keep Assist (LKA) standby
 - Lane Keep Assist (LKA) status indicator (green): Lane Keep Assist (LKA) active
 - Lane Keep Assist (LKA) status indicator (orange): Lane Keep Assist (LKA) malfunction
8. **Speed control status indicator/set distance indicator/lane marker indicator** ()
Displays the status of speed control by the color of the indicator, and displays the



selected distance by the number of horizontal bars shown

- Speed control status indicator (white): ACC standby
 - Speed control status indicator (green): ACC (distance control mode) is active
- Green vehicle icon displayed: Vehicle detected ahead
- No vehicle icon shown: No vehicle detected ahead (Your vehicle maintains the driver-selected set speed.)
- Speed control status indicator (orange): Indicates an ACC malfunction
- For the lane marker indicator, see “Lane Keep Assist (LKA) display and indicators” (P.5-118).
9. **Vehicle set speed indicator**
Indicates the vehicle set speed
10. **Vehicle set speed indicator (if so equipped)**
Indicates the vehicle set speed
11. **Road information indicator (if so equipped)** ( , )
Indicates the detected road information
- For additional information, see “Speed Adjust by Route - a feature of MI-PILOT Assist with Navi-link” (P.5-110).

12. **Detected speed limit sign indicator (if so equipped)** ()

Indicates the currently detected speed limit sign

For additional information, see “Speed Limit Assist - a feature of MI-PILOT Assist with Navi-link” (P.5-108).

13. **Speed Limit Assist indicator (if so equipped)** ( ,  , )

Indicates the Speed Limit Assist activation mode or system operation

For additional information, see “Speed Limit Assist - a feature of MI-PILOT Assist with Navi-link” (P.5-108).

NOTE:

When the MI-PILOT Assist system is activated, the display will automatically be switched to the MI-PILOT Assist system display. To disable this function, turn “Transition (Cruise)” off under “Customize Display” of the settings menu.

The MI-PILOT Assist display is also shown in the Head-Up Display (HUD) (if so equipped). (See “Head-Up Display (HUD)” (P.2-43).)

TURNING THE CONVENTIONAL (fixed speed) CRUISE CONTROL MODE ON

NOTE:

MI-PILOT Assist provides no approach warnings, automatic braking, or Lane Keep Assist (LKA) in the conventional (fixed speed) cruise control mode.

To choose the conventional (fixed speed) cruise control mode, push and hold the MI-PILOT Assist switch for longer than approximately 1.5 seconds. For additional information, see “Conventional (fixed speed) cruise control mode” (P.5-122).

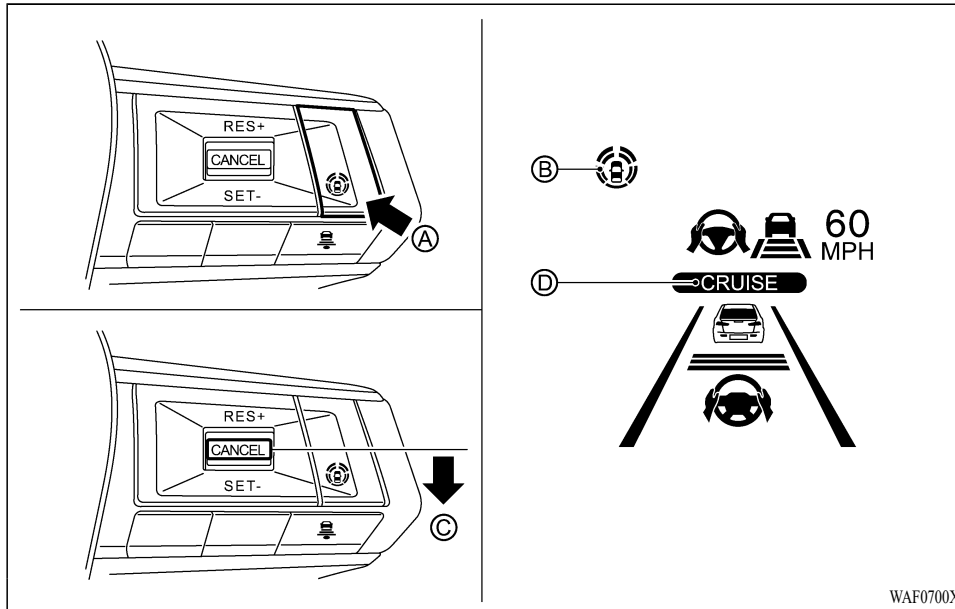

Example

OPERATING MI-PILOT ASSIST

1. Push the MI-PILOT Assist switch (A). This turns on the MI-PILOT Assist system.
 - The MI-PILOT Assist status indicator (B) illuminates in white.
 - A screen is displayed for a period of time that indicates the status of the Driving Aid functions.

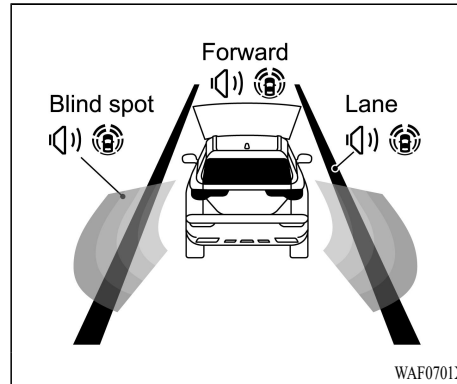

Example (all enabled)

When the Driving Aids are enabled:

Zone	Driving Aid	Display
Forward	Forward Collision Mitigation System (FCM)	Outline
	Predictive Forward Collision Warning (PFCW)	
Lane	Lane Departure Warning (LDW)	Shaded
	Lane Departure Prevention (LDP)	Shaded

Blind Spot	Blind Spot Warning (BSW)	Outline
	Active Blind Spot Assist (ABSAs)	Shaded

- When any of the “Warning” systems are enabled, the “(A)” mark is shown in each zone.
- When any of the “Intervention” systems are enabled, the “(B)” mark is shown in each zone.
- When no system is enabled, “OFF” is shown in each zone.

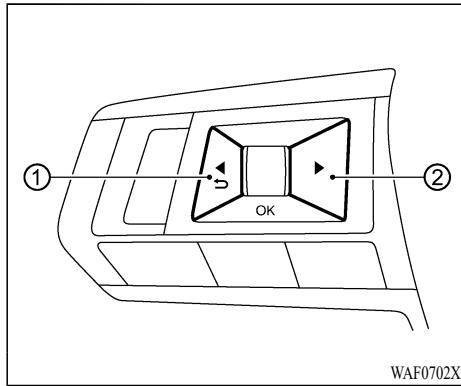

To change the status of the Driving Aids, use ① or ② to navigate the settings screen. For additional information, see “How to use the multi-information display” (P.2-21).

2. Accelerate or decelerate your vehicle to the desired speed and push down the SET-switch ③.

The MI-PILOT Assist system begins to automatically maintain the vehicle set speed. The MI-PILOT Assist activation indicator ④ and MI-PILOT Assist status indicator ⑤ illuminate in green. When a vehicle ahead is detected and traveling at a speed of 20 MPH (30 km/h) or below and the SET- switch is pushed down, the vehicle set speed is 20 MPH (30 km/h).

NOTE:

When the LDP and ABSA systems are enabled in the settings menu of the multi-information display, turning the MI-PILOT Assist system on will turn on the LDP and ABSA systems at the same time. If the LDP system is disabled in the settings menu, the LDP system will automatically be turned on when the Lane Keep Assist (LKA) system is active. For additional information, see “Lane Departure Prevention (LDP)” (P.5-38), “Lane Departure Prevention (LDP)” (P.5-119) and “Active Blind Spot Assist (ABSA)” (P.5-51).

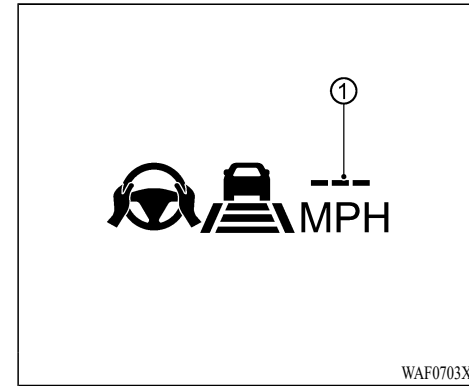

When the SET- switch is pushed down under the following conditions, the MI-PILOT Assist system cannot be set and the vehicle set speed indicator ① blinks for approximately 2 seconds and “Currently Not Available” message will appear in the multi-information display.

- When traveling below 20 MPH (30 km/h) and a vehicle ahead is not detected
- When the shift lever is moved out of the D (Drive) position or into the manual shift mode
- When the parking brake is applied
- When the brakes are operated by the driver
- When the ASC system is off. For additional information, see “Active stability control

Starting and driving 5-99

(ASC)” (P.5-159).

- When the ASC system (including the traction control system) is activated
- When the SNOW mode, GRAVEL mode or MUD mode (AWC model) is selected
- When a wheel is slipping
- When any door is open
- When the driver’s seat belt is not fastened

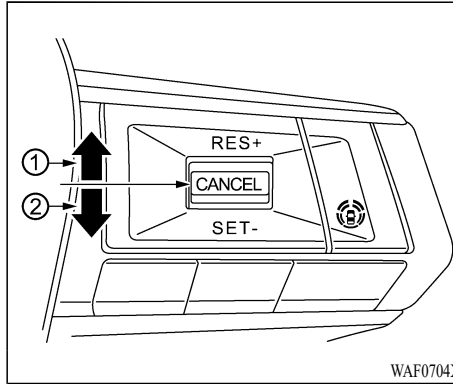

How to change the set vehicle speed

The set vehicle speed can be adjusted.

To change to a faster cruising speed:

- Push up and hold the RES+ switch ①. The set vehicle speed increases in increments of 5 MPH (5 km/h).
- Push up, then quickly release the RES+ switch ①. Each time you do this, the set vehicle speed increases by 1 MPH (1 km/h).

To change to a slower cruising speed:

- Push down and hold the SET- switch ②. The set vehicle speed decreases in increments of 5 MPH (5 km/h).

- Push down, then quickly release the SET- switch ②. Each time you do this, the set vehicle speed decreases by 1 MPH (1 km/h).

For MI-PILOT Assist with Navi-link equipped vehicles: The set vehicle speed can also be changed according to the speed limit sign. (See “Speed Limit Assist - a feature of MI-PILOT Assist with Navi-link” (P.5-108).)

How to momentarily accelerate or decelerate

- Depress the accelerator pedal when acceleration is required. Release the accelerator pedal to resume the previously set vehicle speed.
- Depress the brake pedal when deceleration is required. Control by the MI-PILOT Assist system is canceled. Push up the RES+ switch to resume the previously set vehicle speed.

WARNING

When the accelerator pedal is depressed and you are approaching the vehicle ahead, the ACC system will neither control the brake nor warn the driver with the chime and display. The driver must manually control the vehicle speed to maintain a safe distance to the vehicle ahead. Failure to do so could result in severe

personal injury or death.

NOTE:

When you accelerate by depressing the accelerator pedal or decelerate by pushing down the SET- switch and the vehicle travels faster than the speed set by the driver, the set vehicle speed indicator will blink.

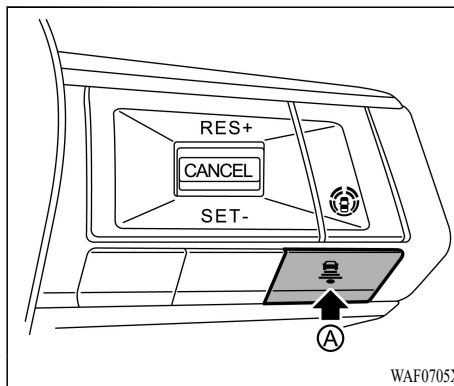

How to change the set distance to the vehicle ahead

The distance to the vehicle ahead can be selected at any time.

Each time the DISTANCE switch Ⓐ is pushed, the set distance will change to “long”, “middle”, “short” and back to “long” again in that sequence.

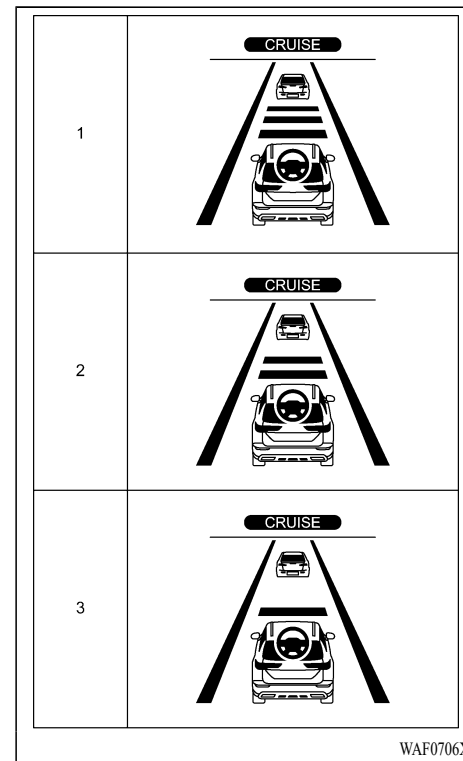

Example

Distance — approximate distance at 60 MPH (100 km/h)

1. Long – 200 ft (60 m)
2. Middle – 150 ft (45 m)
3. Short – 90 ft (30 m)

- The distance to the vehicle ahead changes automatically according to the vehicle speed. The higher the vehicle speed, the longer the distance.
- The distance setting will remain at the current setting even if the engine is restarted.

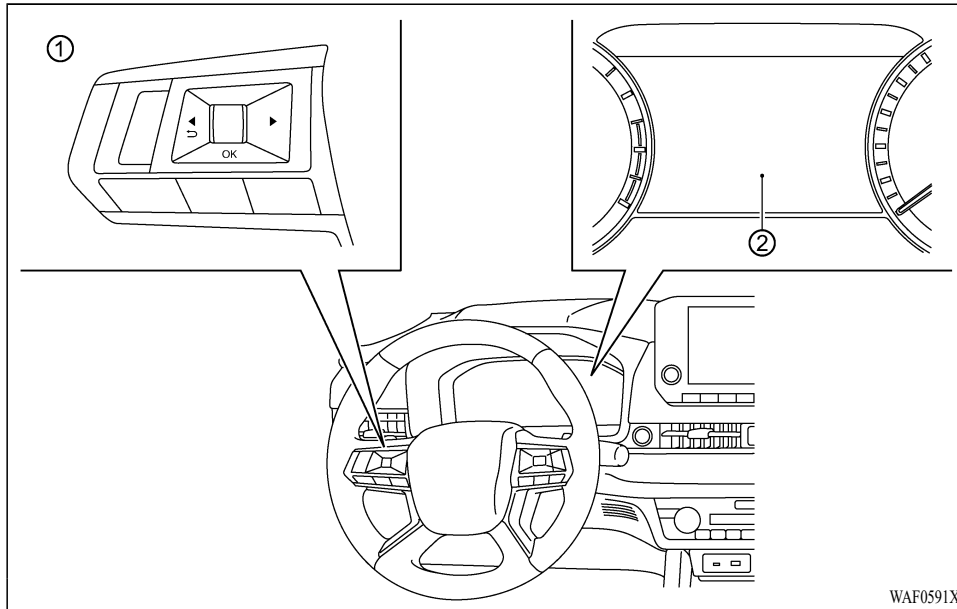

- ① Steering wheel remote control switches (left side)
- ② Multi-information display

HOW TO ENABLE/DISABLE THE LANE KEEP ASSIST (LKA)

Use the following methods to enable or disable the Lane Keep Assist (LKA).

1. Push the ◀ ▶ button on the steering wheel ① until “Settings” appears in the multi-information display ② and then push the scroll dial.
2. Use the scroll dial to select “Driver Assistance.” Then push the scroll dial.
3. Select “Steering Assist” and push the scroll dial to turn the Lane Keep Assist (LKA) on or off.

NOTE:

- When the Cruise screen is displayed on the multi-information display, push the scroll dial on the steering wheel to call up the “Driver Assistance” setting display.
- When enabling/disabling the system through the multi-information display, the system retains the current settings even if the engine is restarted.

HOW TO CANCEL THE MI-PILOT ASSIST SYSTEM

To cancel the MI-PILOT Assist system, use one of the following methods:

- Push the CANCEL switch.
- Tap the brake pedal (except at a standstill).
- Push the MI-PILOT Assist switch to turn the system off. The MI-PILOT Assist status indicator will turn off.

When the MI-PILOT Assist system is canceled

while the vehicle is stopped, the electronic parking brake is automatically activated.

WARNING

To prevent the vehicle from moving or rolling unexpectedly, which could result in serious personal injury or property damage, before exiting the vehicle make sure to push the MI-PILOT Assist switch to turn the system off, push the park button to shift to the P (Park) position, and turn the engine off.

ADAPTIVE CRUISE CONTROL SYSTEM (ACC) WITH STOP & GO

- The Adaptive Cruise Control System(ACC) is a part of the MI-PILOT Assist system. To choose the Adaptive Cruise Control System (ACC) system without the Lane Keep Assist (LKA), activate the MI-PILOT Assist and then turn off the Lane Keep Assist (LKA). For additional information, see “Operating MI-PILOT Assist” (P.5-98) and “How to enable/disable the Lane Keep Assist (LKA)” (P.5-102).
- To choose the conventional (fixed speed) cruise control mode, push and hold the MI-PILOT Assist switch for longer than approximately 1.5 seconds. For additional

information, see “Conventional (fixed speed) cruise control mode” (P.5-122).

WARNING

Failure to follow the warnings and instructions for proper use of the ACC system could result in serious injury or death.

- The ACC system is only an aid to assist the driver and is not a collision warning or avoidance device. It is recommended for highway use only and it is not intended for city driving. It is the driver’s responsibility to stay alert, drive safely, and be in control of the vehicle at all times.
- There are limitations to the ACC system capability. The ACC system does not function in all driving, traffic, weather, and road conditions. It is the driver’s responsibility to stay alert, drive safely, keep the vehicle in the traveling lane, and be in control of the vehicle at all times.
- Always observe posted speed limits and do not set the speed over them.
- The ACC system does not react to stationary and slow moving vehicles.
- Always drive carefully and attentively when using the ACC system. Read and understand the Owner’s Manual thoroughly before using the ACC system. To avoid serious injury or death, do not rely

on the system to prevent accidents or to control the vehicle's speed in emergency situations. Do not use the ACC system except in appropriate road and traffic conditions.

ACC system operation

The ACC system is designed to maintain a selected distance from the vehicle in front of you and can reduce the speed to match a slower vehicle ahead. The system decelerates the vehicle as necessary and if the vehicle ahead comes to a stop, the vehicle decelerates to a standstill. However, the ACC system can only apply up to 40% of the vehicle's total braking power.

This system should only be used when traffic conditions allow vehicle speeds to remain fairly constant or when vehicle speeds change gradually. If a vehicle moves into the traveling lane ahead or if a vehicle traveling ahead rapidly decelerates, the distance between vehicles may become closer because the ACC system cannot decelerate the vehicle quickly enough. If this occurs, the ACC system sounds a warning chime and blinks the system display to notify the driver to take necessary action.

The ACC system cancels and a warning chime sounds if the speed is below approximately 15 MPH (25 km/h) and a vehicle is not detected

ahead. For MI-PILOT Assist with Navi-link equipped vehicles on a limited access freeway as identified in the navigation map data, the ACC system cancels and a warning chime sounds if your vehicle is at a standstill for more than approximately 3 seconds and a vehicle is not detected ahead.

The ACC system operates as follows:

- When there are no vehicles traveling ahead, the ACC system maintains the speed set by the driver. The vehicle set speed range is between approximately 20 and 90 MPH (30 and 144 km/h).
- When there is a vehicle traveling ahead, the ACC system adjusts the speed to maintain the distance, selected by the driver, from the vehicle ahead. If the vehicle ahead comes to a stop, the vehicle decelerates to a standstill. Once your vehicle stops, the ACC system keeps the vehicle stopped.
- When the vehicle traveling ahead moves to a different traveling lane, the ACC system accelerates and maintains vehicle speed up to the set speed.

The ACC system does not control vehicle speed or warn you when you approach stationary and slow moving vehicles. You must pay attention to vehicle operation to maintain proper distance from vehicles ahead when approaching toll gates or traffic congestion.

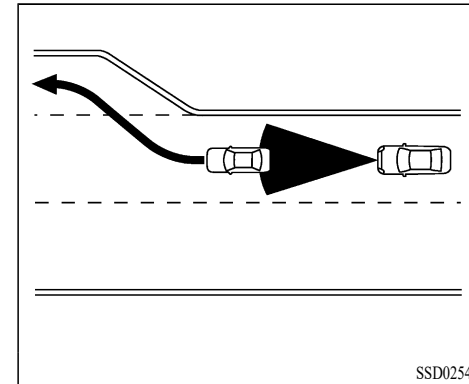

When driving on the highway at a vehicle set speed and approaching a slower traveling vehicle ahead, the ACC system adjusts the speed to maintain the distance, selected by the driver, from the vehicle ahead. If the vehicle ahead changes lanes or exits the highway, the ACC system accelerates and maintains the vehicle set speed. Pay attention to the driving operation to maintain control of the vehicle as it accelerates to the set speed.

The vehicle may not maintain the set speed on winding or hilly roads. If this occurs, you will have to manually control the vehicle speed.

Normally when controlling the distance to a vehicle ahead, the system automatically accelerates or decelerates your vehicle according to

the speed of the vehicle ahead.

Depress the accelerator to properly accelerate your vehicle when acceleration is required for a lane change. Depress the brake pedal when deceleration is required to maintain a safe distance to the vehicle ahead due to sudden braking or if a vehicle cuts in. Always stay alert when using the ACC system.

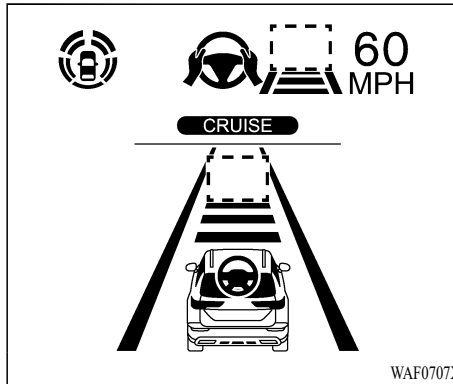

System set display — no vehicle detected ahead*

No vehicle detected ahead:

The driver sets the desired vehicle speed based on the road conditions. The ACC system maintains the vehicle set speed, similar to standard cruise control, as long as no vehicle is detected in the lane ahead. The ACC system displays the vehicle set speed.

*: The design of the set display may differ depending on the model.

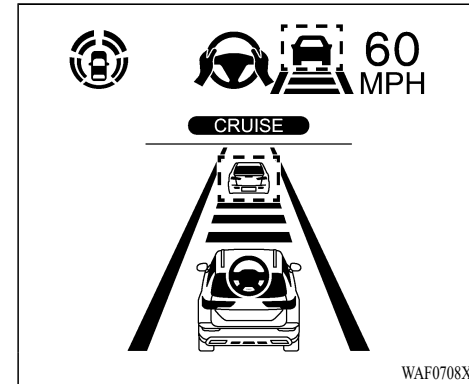

System set display — vehicle ahead*

Vehicle detected ahead:

When a vehicle is detected in the lane ahead, the ACC system decelerates the vehicle by controlling the throttle and applying the brakes to match the speed of a slower vehicle ahead. The ACC system then adjusts the vehicle speed based on the speed of the vehicle ahead to maintain the driver selected distance.

NOTE:

- The stop lights of the vehicle come on when braking is performed by the ACC system.
- When the brake is applied by the system, a noise may be heard. This is not a malfunction.

When the ACC system detects a vehicle ahead, the vehicle ahead detection indicator and the speed control status indicator (distance control mode) illuminates in green.

*: The design of the set display may differ depending on the model.

Vehicle ahead stops:

When a vehicle ahead is detected and it gradually decelerates to stop, your vehicle decelerates to a standstill. When your vehicle is at a standstill, the “(RES+) Follow Vehicle Ahead” message is displayed on the multi-information display.

Vehicle ahead accelerates:

- When your vehicle is stopped for less than approximately 3 seconds and the vehicle ahead begins to move, your vehicle will start moving again automatically.
- When your vehicle is at a standstill for more than approximately 3 seconds and the vehicle ahead begins to accelerate, push up the RES+ switch or lightly depress the accelerator pedal. The ACC system starts to follow the vehicle ahead.
- Always check surroundings before restarting the vehicle.
- For vehicles equipped with MI-PILOT Assist with Navi-link and only when on a limited access freeway (as identified in the

navigation map data):

- The time the vehicle can remain stopped and automatically restart is extended from 3 seconds to 30 seconds.
- If a vehicle ahead cuts in or out of the lane ahead, the vehicle may not automatically start when the traffic ahead begins to move. You need to push up the RES+ switch or lightly depress the accelerator pedal to follow the vehicle directly ahead when it is safe to do so.

Vehicle ahead not detected:

When a vehicle is no longer detected ahead, the ACC system gradually accelerates your vehicle to resume the previously vehicle set speed. The ACC system then maintains the vehicle set speed.

When a vehicle is no longer detected, the vehicle ahead detection indicator and speed control status indicator (maintain speed control mode) turn off.

The ACC system gradually accelerates to the vehicle set speed, but you can depress the accelerator pedal to quickly accelerate. When a vehicle is no longer detected and your vehicle is traveling under approximately 15 MPH (25 km/h), the ACC system automatically cancels. For MI-PILOT Assist with Navi-link equipped vehicles on a limited access freeway as

identified in the navigation map data, the ACC system cancels and a warning chime sounds if your vehicle is at a standstill for more than approximately 3 seconds and a vehicle is not detected ahead.

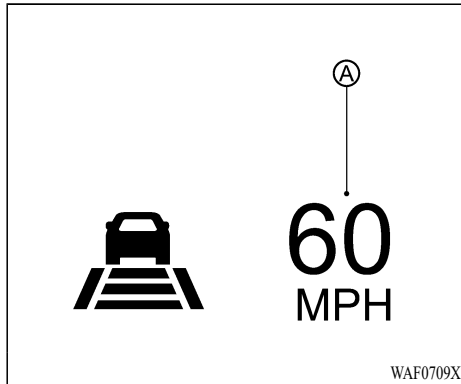

When passing another vehicle, the vehicle set speed indicator Ⓐ flashes when the vehicle speed exceeds the set speed. The vehicle ahead detection indicator turns off when the area ahead of the vehicle is open. When the pedal is released, the vehicle returns to the previously set speed. Even though your vehicle speed is set in the ACC system, you can depress the accelerator pedal when it is necessary to accelerate your vehicle rapidly.

Cut-in detection

If a vehicle moves into your traveling lane near your vehicle, the ACC system may inform the driver by flashing the vehicle ahead detection indicator.

Approach warning

If your vehicle comes closer to the vehicle ahead due to rapid deceleration of that vehicle or if another vehicle cuts in, the system warns the driver with the chime and ACC system display. Decelerate by depressing the brake pedal to maintain a safe vehicle distance if:

- The chime sounds.
- The vehicle ahead detection indicator and set distance indicator blink.
- You judge it necessary to maintain a safe distance.

The warning chime may not sound in some cases when there is a short distance between vehicles. Some examples are:

- When the vehicles are traveling at the same speed and the distance between vehicles is not changing.
- When the vehicle ahead is traveling faster and the distance between vehicles is increasing.
- When a vehicle cuts in near your vehicle.

The warning chime will not sound when:

- Your vehicle approaches other vehicles that are parked or moving slowly.
- The accelerator pedal is depressed, overriding the system.

NOTE:

The approach warning chime may sound and the system display may flash when the radar sensor detects objects on the side of the vehicle or on the side of the road. This may cause the ACC system to decelerate or accelerate the vehicle. The radar sensor may detect these objects when the vehicle is driven on winding, narrow, or hilly roads or when the vehicle is entering or exiting a curve. In these cases, you will have to manually control the proper distance ahead of your vehicle.

Also, the sensor sensitivity can be affected by vehicle operation (steering maneuver or driving position in the lane) or traffic or vehicle conditions (for example, if a vehicle is being driven with some damage).

Acceleration when passing

When the ACC system is engaged above 44 MPH (70 km/h) and following a slower vehicle (below the set vehicle speed), and the turn signal is activated to the left, the ACC system will automatically start to accelerate the vehicle to help initiate passing on the left and will begin

to reduce the distance to vehicle directly ahead. Only the left side turn signal operates this feature. As the driver steers the vehicle and moves into the passing lane, if no vehicle is detected ahead the ACC system will continue to accelerate to the set vehicle speed. If another vehicle is detected ahead, then the vehicle will accelerate up to the following speed of that vehicle. If the vehicle is not steered into the left lane to pass, the acceleration will stop after a short time and regain the set following distance. Acceleration can be stopped at any point by depressing the brake pedal or the CANCEL switch on the steering wheel.

WARNING

In order to reduce the risk of a collision that may result in serious injury or death, please be aware of the following:

- This function is only activated with the left turn signal and will briefly accelerate the vehicle even if a lane change is not initiated. This can include non-passing situations such as left side exits.
- Ensure that when passing another vehicle, the adjacent lane is clear before initiating the pass. Sudden changes in traffic may occur while passing. Always manually steer or brake as needed. Never solely rely on the system.

Speed Limit Assist - a feature of MI-PILOT Assist with Navi-link (if so equipped)

WARNING

Listed below are the system limitations for the Speed Limit Assist. Failure to operate the vehicle in accordance with these system limitations could result in serious injury or death:

- It is the driver's responsibility to select the proper speed, follow all traffic regulations and observe other road users.
- The Speed Limit Assist may not operate properly and the actual speed limit may not be applied to the vehicle set speed in all conditions. The driver must manually control the vehicle speed.
 - When the Traffic Recognition Sign (TSR) system is not functioning properly or turned off. (See "Traffic Sign Recognition (TSR)" (P.5-30).)
 - When driving in countries or areas not covered by the navigation system.
 - When crossing national boundaries.

- When driving on the exit of the limited access freeway as identified in the navigation map data.
- When driving in an area with nearby parallel roads (for example, freeway with a parallel service drive).
- When driving in an area where each lane has a different speed limit sign.
- When driving on a road under construction or in a construction zone.
- When the data from the navigation system is not up-to-date or is unavailable.

When the MI-PILOT Assist with Navi-link is active and it detects a change of the speed limit, the new speed limit sign is indicated and it can be applied to the vehicle set speed automatically or manually.

The Speed Limit Assist operates:

- When the detected speed limit sign is 20 MPH (30 km/h) and above.
- The "Spd. Limit Assist" is enabled in the settings menu of the multi-information display.

NOTE:

- While the accelerator pedal is operated with AUTO mode selected, the Speed Limit Assist will function (automatically adjust the vehicle set speed) only when the detected speed limit sign is faster than the vehicle set speed.
- In the following situations, the Speed Limit Assist will not operate:
 - When an increase in the posted speed limit is detected, but the vehicle set speed is already faster than the new speed limit.
 - When a decrease in the posted speed limit is detected, but the vehicle set speed is already lower than the new speed limit.

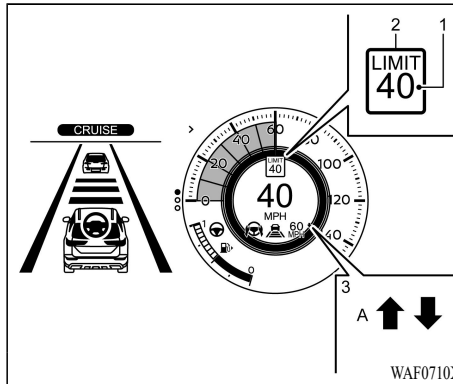

Example

System display and indicators:

1. Detected speed limit sign indicator
Displays the currently detected speed limit sign. For additional information, see “Traffic Sign Recognition (TSR)” (P.5-30).
2. Applied speed limit sign indicator (green frame)
Indicates the detected speed limit sign can be applied to the vehicle set speed.
3. Speed Limit Assist indicator
Indicates the system activation mode or system operation.
“↑” : Manual mode is activated and a

new speed limit sign (faster speed value) is indicated.

“↓” : Manual mode is activated and a new speed limit sign (lower speed value) is indicated.

“A” : Auto mode is activated.

Operating the system:

When the system detects a different speed limit sign, the new speed value is indicated. The vehicle set speed can be changed to the indicated speed limit sign automatically or manually.

When Manual mode is selected on settings menu (factory default setting):

- To accept the newly indicated speed limit, operate the RES+ switch (in case of speed limit up) or SET- switch (in case of speed limit down).
- The Speed Limit Assist indicator (↑ or ↓) will turn off after approximately 10 seconds if the RES+ or SET- switch is not operated. (The Speed Limit Assist indicator can be turned off immediately by operating the opposite switch from the direction indicated by the Speed Limit Assist indicator.)

The system will not activate if a speed limit sign is not detected.

When Auto mode is selected on the settings menu:

- The indicated speed limit sign is applied to the vehicle set speed automatically when on a limited access freeway as identified in the navigation map data. Also, if the MI-PILOT Assist with Navi-link system is ON, but not set (active), and a new speed limit sign is detected, the vehicle set speed is automatically updated.
- The Auto mode may not be available in some regions or on roads other than limited access freeways. In this case, the system operates as the Manual mode.

NOTE:

Auto mode will not function in Hawaii or US island territories.

How to activate or deactivate the system:

1. Push the ◀ ▶ button on the steering wheel until “Settings” appears in the multi-information display, and push the scroll dial.
2. Use the scroll dial to select “Driver Assistance”. Then push the scroll dial.
3. Select “Spd. Limit Assist”, and push the scroll dial to select “Auto” or “Manual” to enable (not activate) the system.

To deactivate the system, select “OFF”.

NOTE:

The system will retain current settings in the multi-information display even if the engine is restarted.

Speed Adjust by Route - a feature of MI-PILOT Assist with Navi-link (if so equipped)

WARNING

Listed below are the system limitations for the Speed Adjust by Route. Failure to operate the vehicle in accordance with these system limitations could result in serious injury or death:

- There are limitations to the Speed Adjust by Route system capability. The system does not function in all driving, traffic, weather and road conditions. It is the driver’s responsibility to stay alert, drive safely, and be in control of the vehicle at all times.
- The Speed Adjust by Route system does not brake the vehicle to a stop. Whenever necessary, the driver must apply appropriate braking.
- It is the driver’s responsibility to select the proper speed, follow all traffic regulations and observe other road users.

- The Speed Adjust by Route system will not function in Hawaii or US island territories.
- The Speed Adjust by Route may not operate properly in some road and traffic conditions, the system may unexpectedly change the speed. The driver must manually control the vehicle speed.
 - When the data from the navigation system is not up-to-date or is unavailable.
 - When not driving along the route suggested by the navigation system.
 - When the navigation system is recalculating the route.
 - When driving in countries or areas not covered by the navigation system.
 - When driving on a road under construction or newly constructed road.
 - When driving near a road split or junction.
 - When driving in bad weather or poor road conditions.

When the MI-PILOT Assist with Navi-link is active on a limited access freeway (as identified

in the navigation map data), the Speed Adjust by Route uses road information provided by the navigation system and can adjust the vehicle speed depending on curves, junctions and exits. The system may not always reduce speed for all curves, junctions or exits and the driver may need to apply additional braking at any time.

When the vehicle is through the curve or junction, the vehicle will accelerate again to the set speed. When exiting the limited access freeway, the driver will need to apply braking at the end of the exit.

NOTE:

- The system does not operate when the accelerator pedal is depressed.
- The system may not operate depending on the set distance to the vehicle ahead and vehicles detected ahead.

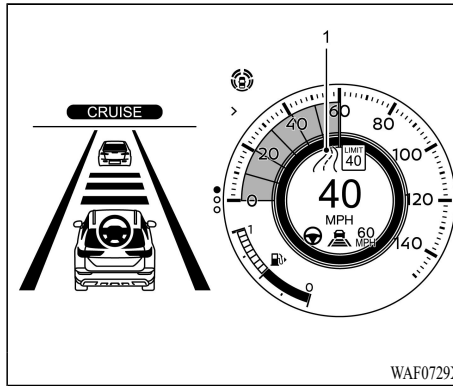

Example

System display and indicators:

1. Road information indicator
Appears when the system adjusts the speed depending on turns or exits.

	Curves and junctions
	Exits

How to activate or deactivate the system:

1. Push the ◀ ▶ button on the steering wheel until “Settings” appears in the multi-information display, and push the scroll dial.
2. Use the scroll dial to select “Driver Assistance”. Then push the scroll dial.
3. Select “Speed Adjust by Route” and push the scroll dial to turn the system on or off.

NOTE:

The system will retain current settings in the multi-information display even if the engine is restarted.

ACC system limitations

! WARNING

Listed below are the system limitations for the ACC system. Failure to operate the vehicle in accordance with these system limitations could result in serious injury or death:

- The ACC system is primarily intended for use on highways and freeways. It is not advisable to use the ACC system in city/urban traffic.
- The ACC system will not adapt automatically to road conditions. This system

should be used in evenly flowing traffic. Do not use the system on roads with sharp curves or on icy roads, in heavy rain or in fog.

- As there is a performance limit to the distance control function, never rely solely on the ACC system. This system does not correct careless, inattentive or absent-minded driving or overcome poor visibility in rain, fog, or other bad weather. Decelerate the vehicle speed by depressing the brake pedal, depending on the distance to the vehicle ahead and the surrounding circumstances in order to maintain a safe distance between vehicles.
- When the ACC system automatically brings the vehicle to a stop, your vehicle can automatically accelerate if the vehicle is stopped for less than approximately 3 seconds. Be prepared to stop your vehicle if necessary.
- For vehicles equipped with MI-PILOT Assist with Navi-link and only when on a limited access freeway (as identified in the navigation map data):
 - The time the vehicle can remain stopped and automatically restart is extended from 3 seconds to 30 seconds.
 - If a vehicle ahead cuts in or out of the lane ahead, the vehicle may not automatically start when the

traffic ahead begins to move. You need to push up the RES+ switch or lightly depress the accelerator pedal to follow the vehicle directly ahead when it is safe to do so.

- Always check surroundings before restarting the vehicle.
- Always pay attention to the operation of the vehicle and be ready to manually control the proper following distance. The ACC system may not be able to maintain the selected distance between vehicles (following distance) or selected vehicle speed under some circumstances.
- The ACC system does not detect the following objects:
 - Stationary or slow moving vehicles (when your vehicle is approaching them)
 - Pedestrians or objects in the roadway
 - Oncoming vehicles in the same lane
 - Motorcycles traveling offset in the travel lane
- The ACC system may not detect a vehicle ahead in certain road, weather or driving conditions. To avoid accidents, never use the ACC system under the following

conditions:

- On roads with heavy, high-speed traffic or sharp curves
- On slippery road surfaces such as on ice or snow, etc.
- On a bumpy road surface, such as an uneven dirt road
- On steep downhill roads (the vehicle may go beyond the vehicle set speed and frequent braking may result in overheating the brakes)
- On repeated uphill and downhill roads
- During bad weather (rain, fog, snow, etc.)
- When the sensor detection is reduced (conditions such as rain, snow, fog, dust storms, sandstorms, and road spray from other vehicles)
- When dirt, ice, snow or other material adhere to the radar sensor area
- When traffic conditions make it difficult to keep a proper distance between vehicles because of fre-

quent acceleration or deceleration

- When a complicated-shaped vehicle such as a car carrier trailer or flatbed truck/trailer is near the vehicle ahead
 - When there is interference by other radar sources
 - When excessively heavy baggage is loaded in the rear seat or cargo area of your vehicle
 - When towing a trailer or other vehicle
- In some road or traffic conditions, a vehicle or object can unexpectedly come into the sensor detection zone and cause automatic braking. Always stay alert and avoid using the ACC system where not recommended in this warning section.
 - The ACC system also uses a multi-sensing front camera. The following are some conditions in which the camera may not properly detect a vehicle and detection of a vehicle ahead may be delayed:
 - Poor visibility (conditions such as rain, snow, fog, dust storms, sandstorms, and road spray from other vehicles)

- The camera area of the windshield is fogged up or covered with dirt, water drops, ice, snow, etc.
- Strong light (for example, sunlight or high beams from oncoming vehicles) enters the front camera
- A sudden change in brightness occurs (for example, when the vehicle enters or exits a tunnel or shaded area or lightning flashes)

The ACC system is designed to automatically check the radar sensor's operation within the limitations of the system.

The detection zone of the radar sensor is limited. A vehicle ahead must be in the detection zone for the ACC system to maintain the selected distance from the vehicle ahead. A vehicle ahead may move outside of the detection zone due to its position within the same lane of travel. Motorcycles may not be detected in the same lane ahead if they are traveling offset from the center line of the lane. A vehicle that is entering the lane ahead may not be detected until the vehicle has completely moved into the lane.

If this occurs, the ACC system may warn you

by blinking the system indicator and sounding the chime. The driver may have to manually control the proper distance away from the vehicle traveling ahead.

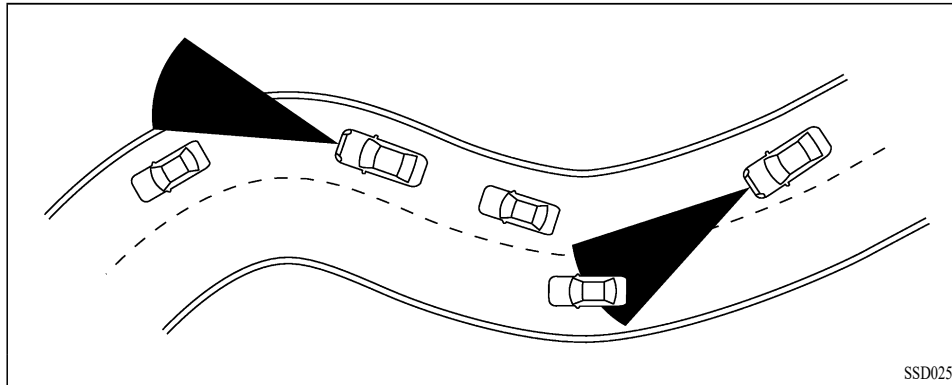
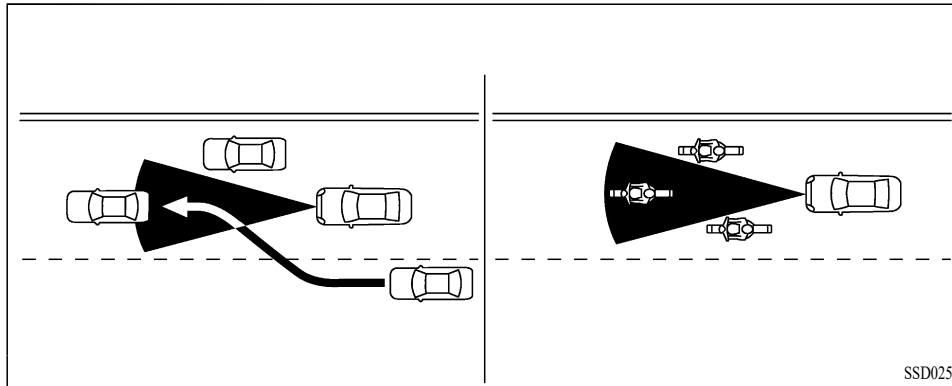

When driving on some roads, such as winding, hilly, curved, narrow roads, or roads which are under construction, the radar sensor may detect vehicles in a different lane, or may temporarily not detect a vehicle traveling ahead. This may cause the ACC system to decelerate or accelerate the vehicle.

The detection of vehicles may also be affected by vehicle operation (steering maneuver or traveling position in the lane, etc.) or vehicle condition.

If this occurs, the ACC system may warn you by blinking the system indicator and sounding the chime unexpectedly. You will have to manually control the proper distance away from the vehicle traveling ahead.

ACC system temporarily unavailable

The following are conditions in which the ACC system may be temporarily unavailable. In these instances, the ACC system may not cancel and may not be able to maintain the selected following distance from the vehicle ahead.

Condition A:

Under the following conditions, the ACC system is automatically canceled. A chime will sound and the system will not be able to be set:

- Any door is open.
- The driver's seat belt is unfastened.
- The vehicle ahead is not detected and your vehicle is traveling below the speed of 15 MPH (25 km/h). For MI-PILOT Assist with Navi-link equipped vehicles on a limited access freeway as identified in the navigation map data, the ACC system cancels and a warning chime sounds if your vehicle is at a standstill for more than approximately 3 seconds and a vehicle is not detected ahead.
- Your vehicle has been stopped by the ACC system for approximately 3 minutes or longer.
- The shift lever is moved out of the D (Drive) position or into the manual shift mode.
- The electronic parking brake is applied.
- The ASC system is turned off.
- The FCM applies harder braking.
- ASC (including the traction control system) operates.
- The SNOW mode, GRAVEL mode or MUD mode (AWC models) is selected.
- A wheel slips.
- When the front radar is impaired due to dirt or an other obstruction blocking the radar sensor.

- When the radar signal is temporarily interrupted.

Action to take:

When the conditions listed above are no longer present, turn the system off using the MI-PILOT Assist switch. Turn the MI-PILOT Assist system back on to use the system.

NOTE:

When the ACC system is canceled under any of the following conditions at a standstill, the electronic parking brake is automatically activated:

- Any door is open.
- The driver's seat belt is unfastened.
- Your vehicle has been stopped by the ACC system for approximately 3 minutes or longer.
- The shift lever is moved out of the D (Drive) position or into the manual shift mode.
- The ASC system is turned off.
- When the front radar is impaired due to dirt or an other obstruction blocking the radar sensor.
- When the radar signal is temporarily interrupted.

Condition B:

When there is inclement weather (rain, fog,

snow, etc.) blocking the front radar sensor, the ACC system will automatically be canceled, the chime will sound and the "Forward Driving Aids temporarily disabled Front Sensor blocked" warning message will appear in the multi-information display.

Action to take:

When the above condition is no longer present, the warning message will no longer be available in the multi-information display and the system will operate normally. If the warning message continues to appear, have the system checked. It is recommended that you visit an authorized Mitsubishi Motors dealer for this service.

Condition C:

When the radar sensor on the front of the vehicle is covered with dirt or is obstructed, the ACC system will automatically be canceled.

The chime will sound and the "Forward Driving Aids temporarily disabled Front Sensor blocked" warning message will appear in the multi-information display.

Action to take:

If the warning message appears, stop the vehicle in a safe place, push the park button to engage the P (Park) position, and turn the engine off. When the radar signal is temporarily interrupted, clean the sensor area and restart the engine. If the warning message continues to

appear, have the system checked. It is recommended that you visit an authorized MITSUBISHI MOTORS dealer for this service.

Condition D:

When driving on roads with limited road structures or buildings (for example, long bridges, deserts, snow fields, driving next to long walls), the system may display the “Forward Driving Aids temporarily disabled Front Sensor blocked” message.

Action to take:

When the above driving conditions no longer exist, turn the system back on.

ACC system malfunction

If the ACC system malfunctions, it will be turned off automatically, a chime will sound, and the speed control status warning (orange) will illuminate.

Action to take:

If the warning illuminates, stop the vehicle in a safe place. Turn the engine off, restart the engine and set the ACC system again. If it is not possible to set the ACC system or the warning stays on, it may be a malfunction. Although the normal driving can be continued, the ACC system should be inspected. It is recommended that you visit an authorized Mitsubishi Motors dealer for this service.

NOTE:

If the ACC system is temporarily unavailable, the conventional cruise control mode may still be used. For additional information, see “Conventional (fixed speed) cruise control mode” (P.5-122).

ACC sensor maintenance

The radar sensor is located on the front of the vehicle.

To keep the ACC system operating properly, be sure to observe the following:

- Always keep the sensor area clean.
- Do not strike or damage the areas around the sensor.
- Do not attach a sticker (including transparent material) or install an accessory near the sensor. This could cause failure or malfunction.
- Do not attach metallic objects near the sensor area (brush guard, etc.). This could cause failure or malfunction.
- Do not alter, remove, or paint the front bumper.

Before customizing or restoring the front bumper, it is recommended that you visit an authorized MITSUBISHI MOTORS dealer.

The camera sensor is located above the inside mirror.

To keep the proper operation of the systems and

prevent a system malfunction, be sure to observe the following:

- Always keep the windshield clean.
- Do not attach a sticker (including transparent material) or install an accessory near the camera unit.
- Do not place reflective materials, such as white paper or a mirror, on the instrument panel. The reflection of sunlight may adversely affect the camera unit’s capability of detecting the lane markers.
- Do not strike or damage the areas around the camera unit. Do not touch the camera lens or remove the screw located on the camera unit.

If the camera unit is damaged due to an accident, it is recommended that you visit an authorized MITSUBISHI MOTORS dealer.

Radio frequency statement:

For USA

Type approval number:

FCC ID: NF3-FR5CPEC

User Manual statement according to §15.19:

This device complies with Part 15 of the FCC Rules.

Operation is subject to the following two conditions:

1. this device may not cause harmful interference, and
2. this device must accept any interference received, including interference that may cause undesired operation.

User Manual statement according to §15.21:

Changes or modifications made to this equipment not expressly approved by Robert BOSCH GmbH may void the FCC authorization to operate this equipment.

User Manual statement according to §15.105:

This equipment has been tested and found to comply with the limits for a Class A digital device, pursuant to Part 15 of the FCC Rules. These limits are designed to provide reasonable protection against harmful interference when the equipment is operated in a commercial environment. This equipment generates, uses, and can radiate radio frequency energy and, if not installed and used in accordance with the instruction manual, may cause harmful interference to radio communications. Operation of this equipment in a residential area is likely to cause harmful interference in which case the user will be required to correct the interference at his own expense.

RF Exposure Information according 2.1091/2.1093/OET bulletin 65:

Radiofrequency radiation exposure information:

This equipment complies with FCC radiation exposure limits set forth for an uncontrolled environment. This equipment should be installed and operated with minimum distance of 20 cm between the radiator and your body.

The transmitter must not be co-located or operating in conjunction with any other antenna or transmitter.

For Canada

Type approval number:

IC: 3387A-FR5CPEC

Legal warning for RF equipment:

This device complies with Industry Canada licence-exempt RSS standard(s). Operation is subject to the following two conditions: (1) this device may not cause interference, and (2) this device must accept any interference, including interference that may cause undesired operation of the device.

Le présent appareil est conforme aux CNR d'Industrie Canada applicables aux appareils radio exempts de licence. L'exploitation est autorisée aux deux conditions suivantes: (1) l'appareil ne doit pas produire de brouillage, et (2) l'utilisateur de l'appareil doit accepter tout brouillage radioélectrique subi, même si le brouillage est susceptible d'en compromettre le fonctionnement.

LANE KEEP ASSIST (LKA)



WARNING

Failure to follow the warnings and instructions for proper use of the Lane Keep Assist (LKA) could result in serious injury or death.

- The Lane Keep Assist (LKA) is not a replacement for proper driving procedures and is not designed to correct careless, inattentive or absent-minded driving. The Lane Keep Assist (LKA) will not always steer the vehicle to keep it in the lane. It is not designed to prevent loss of control. It is the driver's responsibility to stay alert, drive safely, keep the vehicle in the traveling lane, and be in control of the vehicle at all times.
- As there is a performance limit to the Lane Keep Assist (LKA)'s capability, never rely solely on the system. The Lane Keep Assist (LKA) does not function in all driving, traffic, weather, and road conditions. Always drive safely, pay attention to the operation of the vehicle, and manually control your vehicle appropriately.
- The Lane Keep Assist (LKA) is intended for use on well-developed highways with gentle (moderate) curves. To avoid risk of an accident, do not use this system on local or non-highway roads.

- The Lane Keep Assist (LKA) only steers the vehicle to maintain its position in the center of a lane. The vehicle will not steer to avoid objects in the road in front of the vehicle or to avoid a vehicle moving into your lane.
- It is the driver's responsibility to stay alert, drive safely, keep the vehicle in the traveling lane, and be in control of the vehicle at all times. Never take your hands off the steering wheel when driving. Always keep your hands on the steering wheel and drive your vehicle safely.
- Always drive carefully and attentively when using the Lane Keep Assist (LKA). Read and understand the Owner's Manual thoroughly before using the Lane Keep Assist (LKA). To avoid serious injury or death, do not rely on the system to prevent accidents or to control the vehicle's speed in emergency situations. Do not use the Lane Keep Assist (LKA) except in appropriate road and traffic conditions.

Lane Keep Assist (LKA) operation

The Lane Keep Assist (LKA) helps the driver keep the vehicle near the center of the lane when both right and left lane markers are detected. The Lane Keep Assist (LKA) only operates when combined with the Adaptive Cruise Control System (ACC) system. For additional information, see "Adaptive Cruise

Control System (ACC) with Stop & Go" (P.5-103).

The Lane Keep Assist (LKA) can be activated when the following conditions are met:

- The ACC system is activated.
- Lane markers on both sides are clearly detected.
- A vehicle ahead is detected (when the vehicle is driven at speeds under 37 MPH (60 km/h)).
- The driver grips the steering wheel.
- The vehicle is driven at the center of the lane.
- The turn signals are not operated.
- The windshield wiper is not operated in the high speed position (the Lane Keep Assist (LKA) function is disabled after the wiper operates for approximately 10 seconds in the high speed position).

To enable or disable the Lane Keep Assist (LKA), see "How to enable/disable the Lane Keep Assist (LKA)" (P.5-102).

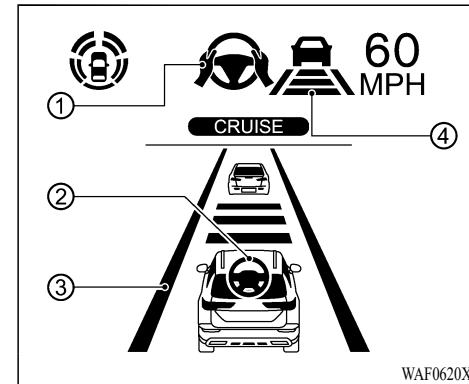

Example

Lane Keep Assist (LKA) display and indicators

1. Lane Keep Assist (LKA) status indicator/warning ①

Displays the status of the Lane Keep Assist (LKA) by the color of the indicator/warning

- Lane Keep Assist (LKA) status indicator (gray): Lane Keep Assist (LKA) standby
- Lane Keep Assist (LKA) status indicator (green): Lane Keep Assist (LKA) active
- Lane Keep Assist (LKA) status indicator (orange): Lane Keep Assist (LKA) malfunction

2. Lane Keep Assist (LKA) indicator ②

Indicates the status of the Lane Keep Assist (LKA) by the color of the indicator

- Lane Keep Assist (LKA) indicator (gray): Lane Keep Assist (LKA) standby
- Lane Keep Assist (LKA) indicator (green): Lane Keep Assist (LKA) active

3. Lane marker indicator ③

Indicates whether the system detects the lane marker

- Lane marker indicator (gray): Lane markers not detected
- Lane marker indicator (green): Lane markers detected
- Lane marker indicator (orange): Lane departure is detected

4. Lane marker indicator/speed control status indicator/set distance indicator ④

Displays the status of the Lane Keep Assist (LKA) by the color of the lane marker indicator.

- Lane marker indicator (gray): Lane Keep Assist (LKA) standby
- Lane marker indicator (green): Lane Keep Assist (LKA) active

For the speed control status indicator and set distance indicator, see “MI-PILOT Assist system display and indicators” (P.5-95).

When the Lane Keep Assist (LKA) is in

operation, the Lane Keep Assist (LKA) status indicator ①, the Lane Keep Assist (LKA) indicator ②, and the lane marker indicator ③ and ④ on the multi-information display turn green. A chime sounds when the Lane Keep Assist (LKA) initially activates.

When the Lane Keep Assist (LKA) deactivates, the Lane Keep Assist (LKA) status indicator ①, the Lane Keep Assist (LKA) indicator ②, and the lane marker indicator ③ and ④ on the multi-information display turn gray and a chime sounds twice.

Lane Departure Prevention (LDP)

With the Lane Keep Assist (LKA) active, when a curve or strong cross wind exceeds the capabilities of the system and your vehicle approaches either the left or the right side of the traveling lane, the LDP system will flash the LDP indicator on the multi-information display and provide steering wheel vibration to alert the driver. The warning chime will also sound (4 rapid beeps). Then, the LDP system automatically applies the brakes for a short period of time to help assist the driver to return the vehicle to the center of the traveling lane. This action is in addition to any Lane Keep Assist (LKA) actions and the warnings cannot be turned off. For more information, see “Lane Departure Prevention (LDP)” (P.5-38).

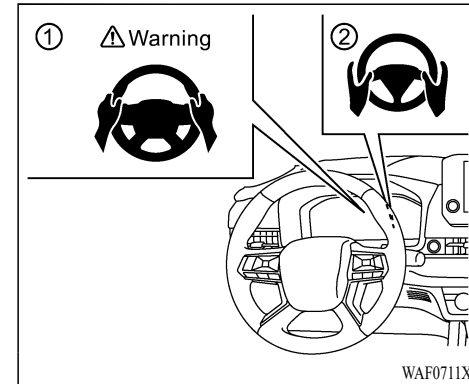

Hands on detection

When the Lane Keep Assist (LKA) is activated, it monitors the driver's steering wheel operation.

If the steering wheel is not operated or the driver takes his/her hands off the steering wheel for a period of time, the warning ① appears in the multi-information display and the hands OFF warning light ② illuminates.

If the driver does not operate the steering wheel after the warning has been displayed and the warning light illuminated, an audible alert sounds and both the warning and the warning light flash. If the driver still does not operate the steering wheel, the system applies a momentary

brake application to request the driver to take control of the vehicle again.

If the driver still does not respond, the system turns on the hazard flasher and slows the vehicle to a complete stop.

The driver can cancel the deceleration at any time by steering, braking, accelerating, or operating the MI-PILOT Assist switch.

WARNING

Lane Keep Assist (LKA) is not a system for a hands-free driving. Always keep your hands on the steering wheel and drive your vehicle safely. Failure to do so could cause a collision resulting in serious personal injury or death.

NOTE:

If the driver lightly touches (instead of firmly grips) the steering wheel, the steering torque sensor may not detect the driver's hand(s) on the steering wheel and a sequence of warnings may occur. When the driver holds and operates the steering wheel again, the warnings turn off.

Lane Keep Assist (LKA) limitations

WARNING

- In the following situations, the camera may not detect lane markers correctly or may detect lane markers incorrectly and the Lane Keep Assist (LKA) may not operate properly:
 - When driving on roads where there are multiple parallel lane markers, lane markers that are faded or not painted clearly, non-standard lane markers, or lane markers covered with water, dirt, snow, etc.
 - When driving on roads with discontinued lane markers
 - When driving on roads with a widening or narrowing lane width
 - When driving on roads where there are multiple lanes or unclear lane markers due to road construction
 - When driving on roads where there are sharply contrasting objects, such as shadows, snow, water, wheel ruts, seams, or lines remaining after road repairs (the

Lane Keep Assist (LKA) could detect these items as lane markers)

- When driving on roads where the traveling lane merges or separates
- Do not use the Lane Keep Assist (LKA) under the following conditions because the system may not properly detect lane markers. Doing so could cause a loss of vehicle control and result in an accident.
 - During bad weather (rain, fog, snow, dust, etc.)
 - When rain, snow, sand, etc., is thrown up by the wheels of other vehicles
 - When dirt, oil, ice, snow, water, or another object adheres to the camera unit
 - When the lens of the camera unit is foggy
 - When strong light (for example, sunlight or high beams from oncoming vehicles) shines on the camera
 - When the headlights are not bright due to dirt on the lens or the headlights are off in tunnels or darkness

- When a sudden change in brightness occurs (for example, when the vehicle enters or exits a tunnel or is under a bridge)
- When driving on roads where the traveling lane merges or separates or where there are temporary lane markers because of road construction
- When there is a lane closure due to road repairs
- When driving on a bumpy road surface, such as an uneven dirt road
- When driving on sharp curves or winding roads
- When driving on repeated uphill and downhill roads
- Do not use the Lane Keep Assist (LKA) under the following conditions because the system will not operate properly:
 - When driving with a tire that is not within normal tire conditions (for example, tire wear, abnormal tire pressure, installation of a spare tire, tire chains, non-standard wheels)

- When the vehicle is equipped with non-original brake or suspension parts
- When an object such as a sticker or cargo obstructs the camera
- When excessively heavy baggage is loaded in the rear seat or luggage area of your vehicle
- When the vehicle load capacity is exceeded
- When towing a trailer or other vehicle
- Excessive noise will interfere with the warning chime sound, and the beep may not be heard.
- For the MI-PILOT Assist system to operate properly, the windshield in front of the camera must be clean. Replace worn wiper blades. The correct size wiper blades must be used to help make sure the windshield is kept clean. Only use MITSUBISHI MOTORS genuine wiper blades, or equivalent wiper blades, that are specifically designed for use on your vehicle model and model year. It is recommended that you visit your MITSUBISHI MOTORS dealer for the correct parts for your vehicle.

Lane Keep Assist (LKA) temporary standby

Automatic standby due to driving operation:

When the driver activates the turn signal, the Lane Keep Assist (LKA) is temporarily placed in a standby mode. (The Lane Keep Assist (LKA) restarts automatically when the operating conditions are met again.)

Automatic standby:

In the following cases, “Not Available Front Camera Obstructed” warning message appears in the multi-information display, along with the chime, and the Lane Keep Assist (LKA) is placed in a temporary standby mode. (The Lane Keep Assist (LKA) restarts automatically when the operating conditions are met again.)

- When lane markers on both sides are no longer detected
- When a vehicle ahead is no longer detected under approximately 37 MPH (60 km/h)

NOTE:

For MI-PILOT Assist with Navi-link equipped vehicles on a limited access freeway as identified in the navigation map data, the Lane Keep Assist (LKA) system may continue to operate with visible lane markers on the both sides, even when the vehicle speed is below approximately 37 MPH (60 km/h) and a vehicle is not detected ahead.

Lane Keep Assist (LKA) cancel

Under the following conditions, the Lane Keep Assist (LKA) cancels, and the Lane Keep Assist (LKA) status indicator and the Lane Keep Assist (LKA) indicator turn off:

- When unusual lane markers appear in the traveling lane or when the lane marker cannot be correctly detected for some time due to certain conditions (for example, a snow rut, the reflection of light on a rainy day, the presence of several unclear lane markers)
- When the windshield wiper operates in the high speed operation (the Lane Keep Assist (LKA) is disabled when the wiper operates for more than approximately 10 seconds)

Action to take:

Turn the ACC system off using the CANCEL switch. When the conditions listed above are no longer present, turn the ACC system on again.

Lane Keep Assist (LKA) malfunction

When the system malfunctions, it turns off automatically. The Lane Keep Assist (LKA) status warning (orange) illuminates. A chime may sound depending on the situation.

Action to take:

Stop the vehicle in a safe location, push the park button to shift to the P (Park) position, turn the engine off, restart the engine, resume driving, and set the ACC system again. If the warning (orange) continues to illuminate, the Lane Keep Assist (LKA) is malfunctioning. Although the vehicle is still drivable under normal conditions, have the system checked. It is recommended that you visit an authorized Mitsubishi Motors dealer for this service.

Lane Keep Assist (LKA) maintenance

The camera is located above the inside mirror. To keep the proper operation of the system and prevent a system malfunction, be sure to observe the following:

- Always keep the windshield clean.
- Do not attach a sticker (including transparent material) or install an accessory near the camera unit.
- Do not place reflective materials, such as white paper or a mirror, on the instrument panel. The reflection of sunlight may adversely affect the camera unit's capability of detecting the lane markers.
- Do not strike or damage the areas around the camera unit. Do not touch the camera lens or remove the screw located on the

camera unit.

If the camera unit is damaged due to an accident, it is recommended that you visit an authorized Mitsubishi Motors dealer.

CONVENTIONAL (fixed speed) CRUISE CONTROL MODE

NOTE:

MI-PILOT Assist provides no approach warnings, automatic braking, or Lane Keep Assist (LKA) in the conventional (fixed speed) cruise control mode.

This mode allows driving at a speed between 20 to 90 MPH (30 to 144 km/h) without keeping your foot on the accelerator pedal.

WARNING

- **In the conventional (fixed speed) cruise control mode, a warning chime does not sound to warn you if you are too close to the vehicle ahead, as neither the presence of the vehicle ahead nor the vehicle-to-vehicle distance is detected.**
- **Pay special attention to the distance between your vehicle and the vehicle ahead of you or a collision could occur.**
- **Always confirm the setting in the ACC system display.**

- Do not use the conventional (fixed speed) cruise control mode when driving under the following conditions:
 - When it is not possible to keep the vehicle at a set speed
 - In heavy traffic or in traffic that varies in speed
 - On winding or hilly roads
 - On slippery roads (rain, snow, ice, etc.)
 - In very windy areas
- Doing so could cause a loss of vehicle control and result in an accident.

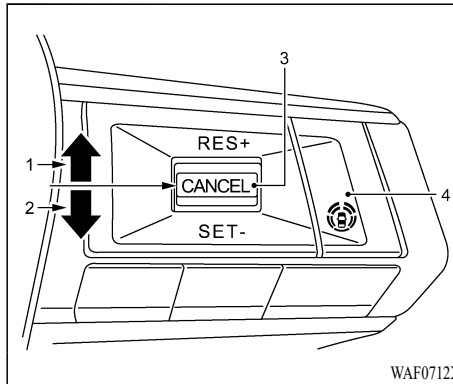

Conventional (fixed speed) cruise control switches

1. RES+ switch:
Resumes set vehicle speed or increases speed incrementally
2. SET- switch:
Sets desired cruise speed or reduces speed incrementally
3. CANCEL switch:
Deactivates the system without erasing the set vehicle speed
4. MI-PILOT Assist switch:
Turns the MI-PILOT Assist system on or off

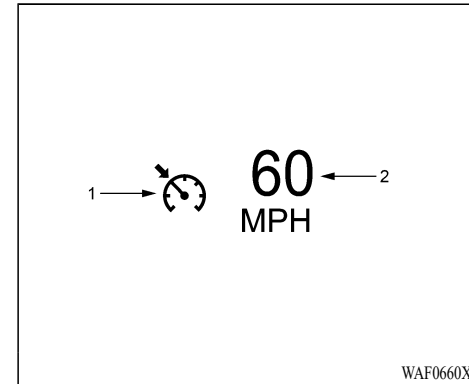

Conventional (fixed speed) cruise control mode display and indicators

The display is located in the multi-information display.

1. Cruise indicator:
This indicator indicates the condition of the ACC system depending on a color.
 - Cruise control ON indicator (gray):
Indicates that the MI-PILOT Assist switch is on
 - Cruise control SET indicator (green):
Indicates that the cruising speed is set
 - Cruise control warning (orange):
Indicates that there is a malfunction in the

ACC system

2. Set vehicle speed indicator:

This indicator indicates the set vehicle speed.

For Canadian models, the speed is displayed in km/h.

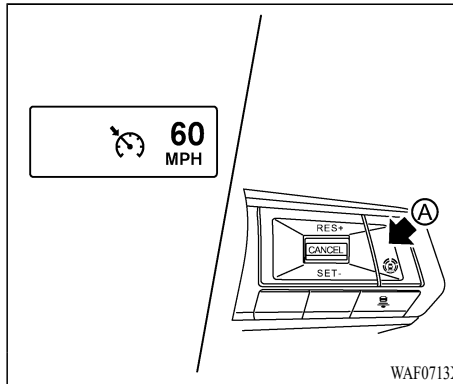

Operating conventional (fixed speed) cruise control mode

To turn on the conventional (fixed speed) cruise control mode, push and hold the MI-PILOT Assist switch **A** for longer than about 1.5 seconds.

When pushing the MI-PILOT Assist switch on, the conventional (fixed speed) cruise control mode display and indicators are displayed in the multi-information display. After you hold the MI-PILOT Assist switch on for longer than about 1.5 seconds, the ACC system display turns off. The cruise indicator appears. You can now set your desired cruising speed. Pushing the MI-PILOT Assist switch again will turn the

system completely off. When the ignition switch is placed in the OFF position, the system is also automatically turned off.

To use the ACC system again, quickly push and release the MI-PILOT Assist switch (vehicle-to-vehicle distance control mode) or push and hold it (conventional cruise control mode) again to turn it on.

WARNING

To avoid accidentally engaging cruise control, make sure to turn the MI-PILOT Assist switch off when not using the ACC system.

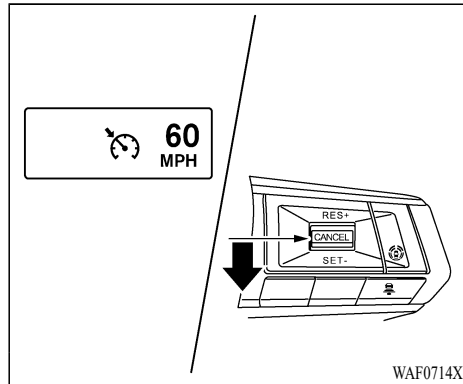

To set cruising speed, accelerate your vehicle to the desired speed, push down the SET- switch and release it. (The color of the cruise indicator changes to green and set vehicle speed indicator comes on.) Take your foot off the accelerator pedal. Your vehicle will maintain the set speed.

- To pass another vehicle, depress the accelerator pedal. When you release the pedal, the vehicle will return to the previously set speed.
- The vehicle may not maintain the set speed when going up or down steep hills. If this happens, manually maintain vehicle speed.

To cancel the preset vehicle speed, use any of the following methods:

1. Push the CANCEL switch. The set vehicle speed indicator will turn off.
2. Tap the brake pedal. The set vehicle speed indicator will turn off.
3. Turn the MI-PILOT Assist switch off. Both the cruise indicator and set vehicle speed indicator will turn off.

To reset at a faster cruising speed, use one of the following three methods:

1. Depress the accelerator pedal. When the vehicle attains the desired speed, push down and release the SET- switch.
2. Push up and hold the RES+ switch. When the vehicle attains the desired speed, release the switch.
3. Push up, then quickly release the RES+ switch. Each time you do this, the set vehicle speed will increase by about 1 MPH (1 km/h).

To reset at a slower cruising speed, use one of the following three methods:

1. Lightly tap the brake pedal. When the vehicle attains the desired speed, push down the SET- switch and release it.
2. Push down and hold the SET- switch. Release the switch when the vehicle slows down to the desired speed.

3. Push down, then quickly release the SET- switch. Each time you do this, the set vehicle speed will decrease by about 1 MPH (1 km/h).

To resume the preset vehicle speed, push up and release the RES+ switch. The vehicle will resume the last set cruising speed when the vehicle speed is over 20 MPH (30 km/h).

FORWARD COLLISION MITIGATION SYSTEM (FCM)

WARNING

Failure to follow the warnings and instructions for proper use of the FCM system could result in serious injury or death.

- The FCM system is a supplemental aid to the driver. It is not a replacement for the driver's attention to traffic conditions or responsibility to drive safely. It cannot prevent accidents due to carelessness or dangerous driving techniques.
- The FCM system does not function in all driving, traffic, weather and road conditions.

The FCM system can assist the driver when there is a risk of a forward collision with the vehicle ahead in the traveling lane or with a pedestrian.

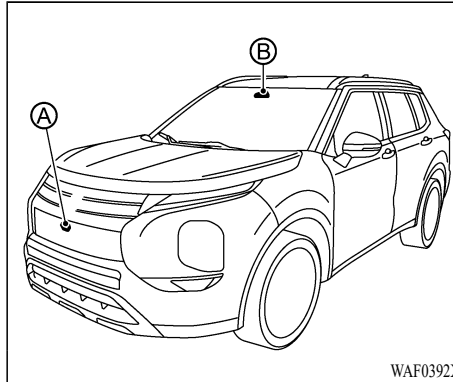

The FCM system uses a radar sensor **A** located on the front of the vehicle to measure the distance to the vehicle ahead in the same lane.

For pedestrians, the FCM system uses a camera **B** installed behind the windshield in addition to the radar sensor.

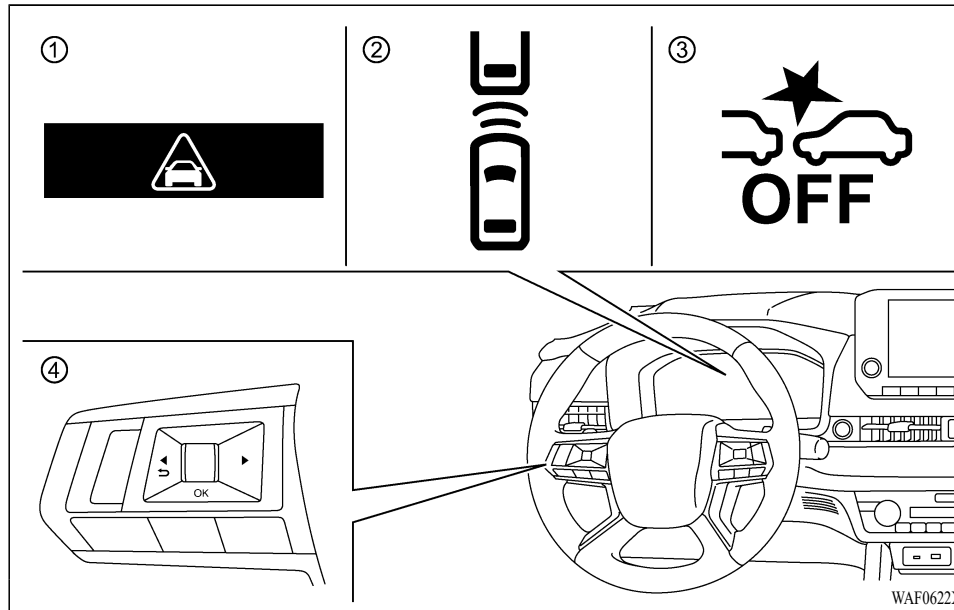

- ① FCM emergency warning indicator
- ② Vehicle ahead detection indicator (on the multi-information display)
- ③ FCM system OFF warning light (on the meter panel)
- ④ Steering wheel remote control switches (left side)

FCM SYSTEM OPERATION

The FCM system will function when your vehicle is driven at speeds above approximately 3 MPH (5 km/h).

For the pedestrian detection function, the FCM system operates at speeds between 6 – 37 MPH (10 – 60 km/h).

If a risk of a forward collision is detected, the FCM system will firstly provide the warning to the driver by flashing the vehicle ahead detection indicator (yellow) in the multi-information display and providing an audible alert. In addition, the system applies partial braking.

If the driver applies the brakes quickly and forcefully after the warning, and the FCM system detects that there is still the possibility of a forward collision, the system will automatically increase the braking force.

If the driver does not take action, the FCM system provide the warning to the driver by flashing FCM emergency warning indicator (red) in the multi-information display and providing an audible alert. Then the system applies partial braking.

If the risk of a collision becomes imminent, the FCM system applies harder braking automatically.

While the FCM system is operating, you may hear the sound of brake operation. This is normal and indicates that the FCM system is operating properly.

NOTE:

The vehicle's stop lights come on when braking is performed by the FCM system.

Depending on vehicle speed and distance to the vehicle or pedestrian ahead, as well as driving

and roadway conditions, the system may help the driver avoid a forward collision or may help mitigate the consequences of a collision should one be unavoidable.

If the driver is handling the steering wheel, accelerating or braking, the FCM system will function later or will not function.

The automatic braking will cease under the following conditions:

- When the steering wheel is turned as far as necessary to avoid a collision.
- When the accelerator pedal is depressed.
- When there is no longer a vehicle or pedestrian detected ahead.

If the FCM system has stopped the vehicle, the vehicle will remain at a standstill for approximately 2 seconds before the brakes are released.

When the brake pedal is depressed while the brake is applied by the system, you may feel the pedal effort is changed and may hear a sound and vibration noise. This is normal and does not indicate a malfunction. In addition, the braking force can be increased by adding the pedal effort.

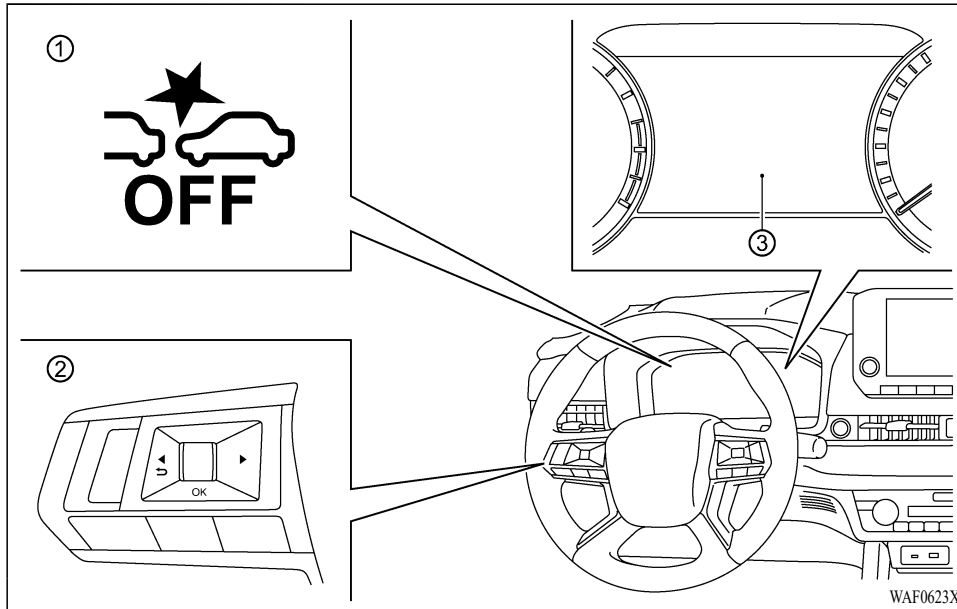

- ① FCM system OFF warning light (on the meter panel)
- ② Steering wheel remote control switches (left side)
- ③ Multi-information display

TURNING THE FCM SYSTEM ON/OFF

Perform the following steps to turn the FCM system on or off.

1. Press the ◀ ▶ button until “Settings” appears in the multi-information display ③

and then push the scroll dial. Use the scroll dial to select “Driver Assistance.” Then push the scroll dial.

2. Select “Emergency Brake” and push the scroll dial.
3. Select “Front” and use the scroll dial to turn the system on or off.

When the FCM system is turned off, the FCM system OFF warning light illuminates ①.

NOTE:

- The FCM system will be automatically turned ON when the engine is restarted.
- The Predictive Forward Collision Warning (PFCW) system is integrated into the FCM system. There is not a separate selection in the display for the PFCW system. When the PFCW system is also turned off.

FCM SYSTEM LIMITATIONS

WARNING

Listed below are the system limitations for the FCM system. Failure to operate the vehicle in accordance with these system limitations could result in serious injury or death.

- The FCM system cannot detect all vehicles or pedestrians under all conditions.

- The FCM system does not detect the following:
 - Pedestrians that are small (for example, children), in a sitting position, operating toys/skateboards, on scooters or in wheelchairs, or not in an upright standing or walking position.
 - Animals of any size.
 - Obstacles (for example, cargo or debris) on the roadway or roadside.
 - Oncoming or crossing vehicles.
 - Vehicles where the tires are difficult to see or the shape of the rear of the vehicle is unclear or obstructed.
 - Parked vehicles.
- The FCM system has some performance limitations.
 - If a stationary vehicle is in the vehicle’s path, the FCM system will not function when the vehicle is driven at speeds over approximately 50 MPH (80 km/h).
 - For pedestrian detection, the FCM system will not function

when the vehicle is driven at speeds over approximately 37 MPH (60 km/h) or below approximately 6 MPH (10 km/h).

- The FCM system may not function for pedestrians in darkness or in tunnels, even if there is street lighting in the area.
- For pedestrians, the FCM system will not issue the first warning.
- The FCM system may not function if the vehicle ahead is narrow (for example a motorcycle).
- The FCM system may not function if speed difference between the two vehicles is too small.
- The FCM system may not function properly or detect a vehicle or pedestrian ahead in the following conditions:
 - Poor visibility (conditions such as rain, snow, fog, dust storms, sandstorms, and road spray from other vehicles)
 - Driving on a steep downhill slope or roads with sharp curves.
 - Driving on a bumpy road surface, such as an uneven dirt road.
 - If dirt, ice, snow, fog or other material is covering the radar sensor area or camera area of

the windshield.

- Interference by other radar sources.
- Strong light (for example, sunlight or high beams from oncoming vehicles) enters the front camera. Strong light causes the area around the pedestrian to be cast in a shadow, making it difficult to see.
- A sudden change in brightness occurs. (For example, when the vehicle enters or exits a tunnel or a shaded area or lightning flashes.)
- In dark or dimly lit conditions, such as at night or in tunnels, including cases where your vehicle's headlights are off or dim, or the tail lights of the vehicle ahead are off.
- When the direction of the camera is misaligned.
- When your vehicle's position or movement is changed quickly or significantly (for example, lane change, turning vehicle, abrupt steering, sudden acceleration or

deceleration).

- When your vehicle or the vehicle or pedestrian ahead moves quickly or significantly such that the system cannot detect and react in time (for example, pedestrian moving quickly toward the vehicle at close range, vehicle cutting in, changing lanes, making a turn, steering abruptly, sudden acceleration or deceleration).
- When the vehicle or pedestrian is offset from the vehicle's forward path.
- If the speed difference between the two vehicles is small.
- The poor contrast of a person to the background, such as having clothing color or pattern which is similar to the background.
- The pedestrian's profile is partially obscured or unidentifiable due to the pedestrian transporting cargo, wearing bulky or very loose-fitting clothing or accessories.
- For approximately 15 seconds after starting the engine

- If the vehicle ahead has a unique or unusual shape, extremely low or high clearance heights, or unusual cargo loading or is narrow (for example, a motorcycle).
- When the vehicle or pedestrian is located near a traffic sign, a reflective area (for example, water on road), or is in a shadow.
- When multiple pedestrians are grouped together.
- When the view of the pedestrian is obscured by a vehicle or other object.
- While towing a trailer or other vehicle.
- The system performance may degrade in the following conditions:
 - The vehicle is driven on a slippery road.
 - The vehicle is driven on a slope.
 - Excessively heavy baggage is loaded in the rear seat or the cargo area of your vehicle.
- The system is designed to automatically check the sensor (radar and camera)'s functionality, within certain limitations. The system may not detect blockage of

sensor areas covered by ice, snow or stickers, for example. In these cases, the system may not be able to warn the driver properly. Be sure that you check, clean and clear sensor areas regularly.

- In some road and traffic conditions, the FCM system may unexpectedly apply partial braking. When acceleration is necessary, depress the accelerator pedal to override the system.
- The FCM system may operate when a pattern, object, shadow or lights are detected that are similar to the outline of vehicles or pedestrians, or if they are the same size and position as a vehicle or motorcycle's tail lights.
- The system may keep operating when the vehicle ahead is turning right or left.
- The system may operate when your vehicle is approaching and passing a vehicle ahead.
- Depending on the road shape (curved road, entrance and exit of the curve, winding road, lane regulation, under construction, etc.), the system may operate temporarily for the oncoming vehicle in front of your vehicle.
- The FCM system may react to:
 - objects on the roadside (traffic sign, guardrail, pedestrian, cyclist, motorcycle, vehicle, etc.)

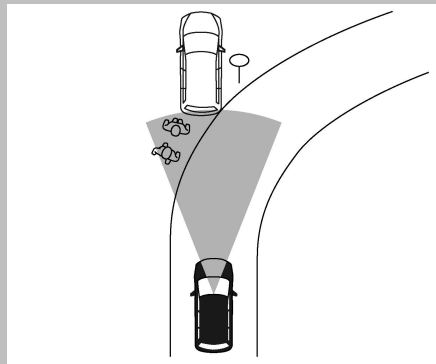

- objects above road (low bridge, traffic sign, etc.)
- objects on the road surface (railroad track, grate, steel plate, etc.)
- objects in the parking garage (beam, pillar, etc.)
- pedestrians, cyclists or motorcycles approaching the traveling lane
- vehicles, pedestrians, cyclists, motorcycles or objects in adjacent lane or close to the vehicle
- oncoming pedestrians

— cyclists

— objects on the road (such as trees)

- Braking distances increase on slippery surfaces.
- Do not use the FCM system if you are towing a trailer. The system may not detect a vehicle ahead.
- Do not use the FCM system when driving with a tire that is not within normal tire conditions (for example, tire wear, low tire pressure, installation of tire chains, non-standard wheels).
- Excessive noise will interfere with the warning chime sound, and the chime may not be heard.

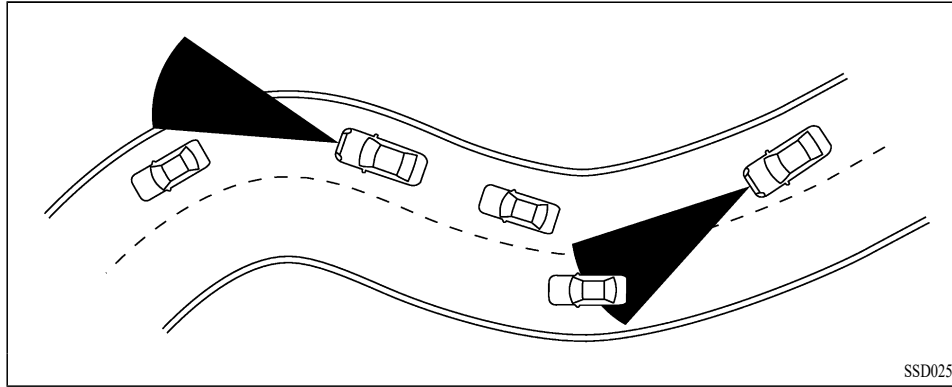

When driving on some roads, such as winding, hilly, curved, narrow roads, or roads which are under construction or on a slope, the sensor may detect vehicles in a different lane, or may temporarily not detect a vehicle traveling ahead. This may cause the system to work inappropriately.

The detection of vehicles may also be affected by vehicle operation (steering maneuver or traveling position in the lane, etc.) or vehicle condition. **If this occurs, the system may warn you by blinking the system indicator and sounding the chime unexpectedly. You will have to manually control the proper distance away from the vehicle traveling ahead.**

SYSTEM TEMPORARILY UN-AVAILABLE

Condition A

If the following conditions, the FCM system OFF warning light will blink (no message appears in the multi-information display).

- Strong light is shining from the front of the vehicle.
- The cabin temperature is over approximately 104°F (40°C) in direct sunlight.
- The camera area of the windshield is misted or frozen.

- The camera unit detects its misalignment condition.
- The radar sensor picks up interference from another radar source.

Action to take:

When the above conditions no longer exist, the FCM system will resume automatically.

NOTE:

When the inside of the windshield on camera area is misted or frozen, it will take a period of time to remove it after air conditioner turns on. If dirt appears on this area, it is recommended you visit an authorized Mitsubishi Motors dealer.

Condition B

In the following condition, the FCM system OFF warning light will flash and the “Forward Driving Aids temporarily disabled Front Sensor blocked” warning message will appear in the multi-information display.

- The sensor area of the front of the vehicle is covered with dirt or is obstructed

Action to take:

If the warning light flashes, stop the vehicle in a safe place and turn the engine off. Clean the radar cover on the front of the vehicle with a soft cloth, and restart the engine. If the warning message continues to illuminate, check that the cover of the sensor is not covered by dirt, snow

or ice. If the warning light is still illuminated, have the FCM system checked. It is recommended that you visit an authorized Mitsubishi Motors dealer for this service.

- When driving on roads with limited road structures or buildings (for example, long bridges, deserts, snow fields, driving next to long walls).

Action to take:

When the above conditions no longer exist, the FCM system will resume automatically.

Condition C

When the Active stability control (ASC) is OFF, the FCM brake will not operate. In this case only visible and audible warning operates. The FCM system warning light (orange) will illuminate.

Action to take:

When the ASC is ON, the FCM system will resume automatically.

SYSTEM MALFUNCTION

If the FCM system malfunctions, it will be turned off automatically, a chime will sound, the FCM system warning light will (orange) will illuminate and the warning message “Malfunction” will appear in the multi-information display.

Action to take:

If the warning light (orange) comes on, stop the vehicle in a safe location. Turn the engine off and restart the engine. If the warning light continues to illuminate, have the FCM system checked. It is recommended that you visit an authorized Mitsubishi Motors dealer for this service.

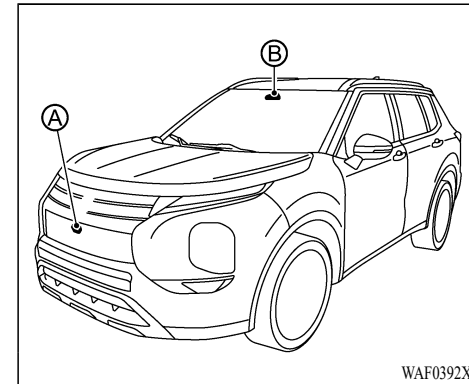

SYSTEM MAINTENANCE

The radar sensor ① is located on the front of the vehicle. The camera ② is located on the upper side of the windshield.

To keep the FCM system operating properly, be sure to observe the following:

- Always keep the sensor area on the front of the vehicle and windshield clean.
- Do not strike or damage the areas around the sensors (ex. vehicle front area, windshield).
- Do not cover or attach stickers or similar objects on the front of the vehicle near the sensor area. This could cause failure or malfunction.

Starting and driving 5-133

- Do not attach metallic objects near the radar sensor area (brush guard, etc.). This could cause failure or malfunction.
- Do not place reflective materials, such as white paper or a mirror, on the instrument panel. The reflection of sunlight may adversely affect the camera unit's detection capability.
- Do not alter, remove or paint the front of the vehicle near the sensor area. Before customizing or restoring the sensor area, it is recommended that you visit an authorized Mitsubishi Motors dealer.

Radio frequency statement

For USA

Type approval number:

FCC ID: NF3-FR5CPEC

User Manual statement according to §15.19:

This device complies with Part 15 of the FCC Rules.

Operation is subject to the following two conditions:

1. this device may not cause harmful interference, and
2. this device must accept any interference received, including interference that may cause undesired operation.

User Manual statement according to §15.21:

Changes or modifications made to this equipment not expressly approved by Robert BOSCH GmbH may void the FCC authorization to operate this equipment.

User Manual statement according to §15.105:

This equipment has been tested and found to comply with the limits for a Class A digital device, pursuant to Part 15 of the FCC Rules. These limits are designed to provide reasonable protection against harmful interference when the equipment is operated in a commercial environment. This equipment generates, uses, and can radiate radio frequency energy and, if not installed and used in accordance with the instruction manual, may cause harmful interference to radio communications. Operation of this equipment in a residential area is likely to cause harmful interference in which case the user will be required to correct the interference at his own expense.

RF Exposure Information according to 2.1091/2.1093/OET bulletin 65:

Radiofrequency radiation exposure information:

This equipment complies with FCC radiation exposure limits set forth for an uncontrolled environment. This equipment should be installed and operated with minimum distance of 20 cm between the radiator and your body.

The transmitter must not be co-located or operating in conjunction with any other antenna or transmitter.

For Canada

Type approval number:

IC: 3387A-FR5CPEC

Legal warning for RF equipment:

This device complies with Industry Canada licence-exempt RSS standard(s). Operation is subject to the following two conditions: (1) this device may not cause interference, and (2) this device must accept any interference, including interference that may cause undesired operation of the device.

Le présent appareil est conforme aux CNR d'Industrie Canada applicables aux appareils radio exempts de licence. L'exploitation est autorisée aux deux conditions suivantes: (1) l'appareil ne doit pas produire de brouillage, et (2) l'utilisateur de l'appareil doit accepter tout brouillage radioélectrique subi, même si le brouillage est susceptible d'en compromettre le fonctionnement.

PREDICTIVE FORWARD COLLISION WARNING (PFCW)

WARNING

Failure to follow the warnings and instructions for proper use of the PFCW system could result in serious injury or death.

- The PFCW system helps warn the driver before a collision but will not avoid a collision. It is the driver's responsibility to stay alert, drive safely and be in control of the vehicle at all times.

The PFCW system can help alert the driver when there is a sudden braking of a second vehicle traveling in front of the vehicle ahead in the same lane.

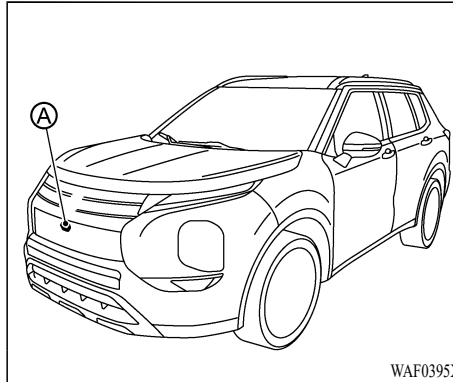

The PFCW system uses a radar sensor  located on the front of the vehicle to measure the distance to a second vehicle ahead in the same lane.

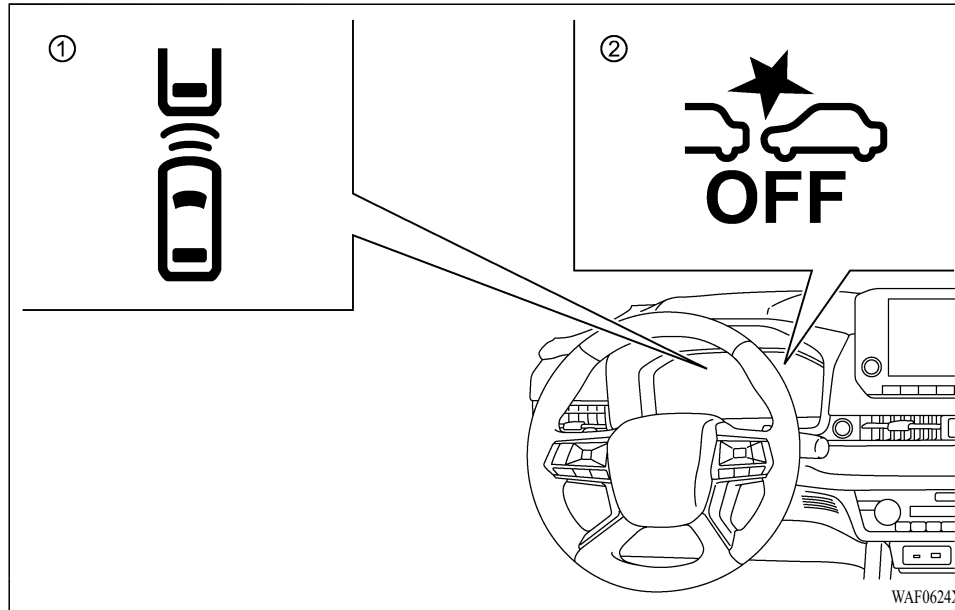

- ① Vehicle ahead detection indicator (on the multi-information display)
- ② Forward Collision Mitigation (FCM) System OFF warning light (on the meter panel)

5-136 Starting and driving

Condition:

[Edit: 2021/ 2/ 10 Model: DG-D]

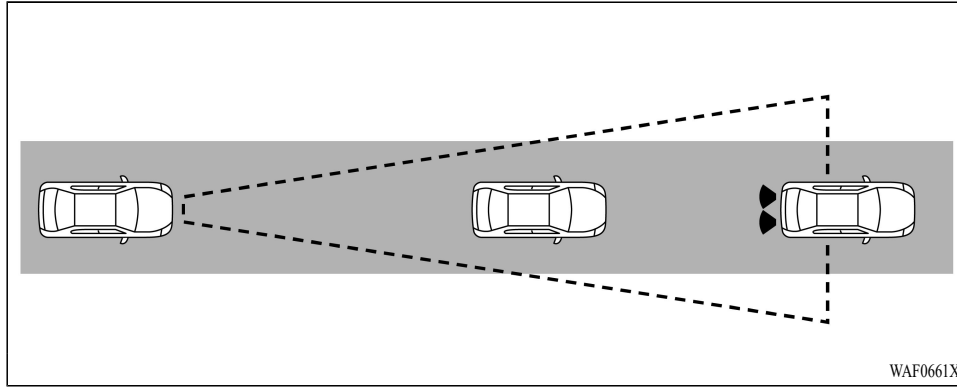

PFCW SYSTEM OPERATION

The PFCW system operates at speeds above approximately 3 MPH (5 km/h).

If there is a potential risk of a forward collision, the PFCW system will warn the driver by blinking the vehicle ahead detection indicator ①, and sounding an audible alert.

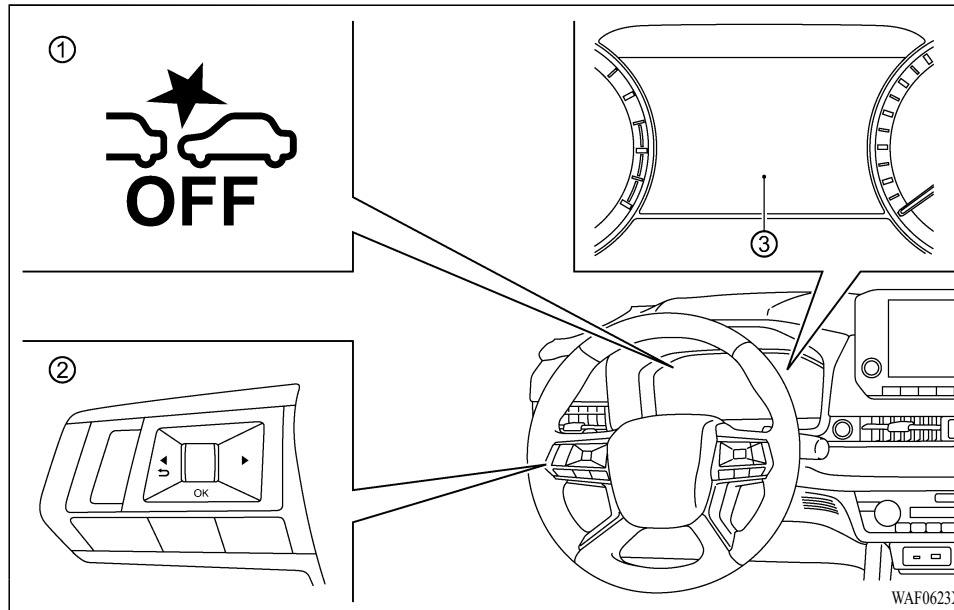

- ① FCM system OFF warning light (on the meter panel)
- ② Steering wheel remote control switches (left side)
- ③ Multi-information display

TURNING THE PFCW SYSTEM ON/OFF

Perform the following steps to turn the PFCW system on or off.

1. Press the ◀ ▶ button until “Settings” appears in the multi-information display ③

and then push the scroll dial. Use the scroll dial to select “Driver Assistance.” Then push the scroll dial.

2. Select “Emergency Brake” and push the scroll dial.
3. Select “Front” and use the scroll dial to turn the system on or off.

When the PFCW system is turned off, the FCM system OFF warning light (orange) ① illuminates.

NOTE:

- The PFCW system will be automatically turned on when the engine is restarted.
- The PFCW system is integrated into the FCM system. There is not a separate selection in the display for the PFCW system. When the FCM system is turned off, the PFCW system is also turned off.

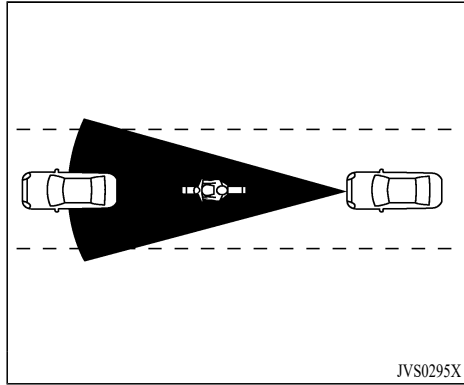

Illustration A

JVS0295X

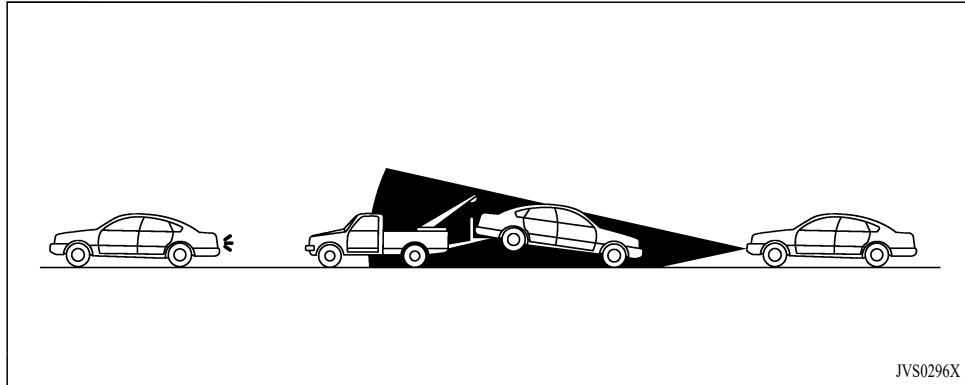

Illustration B

JVS0296X

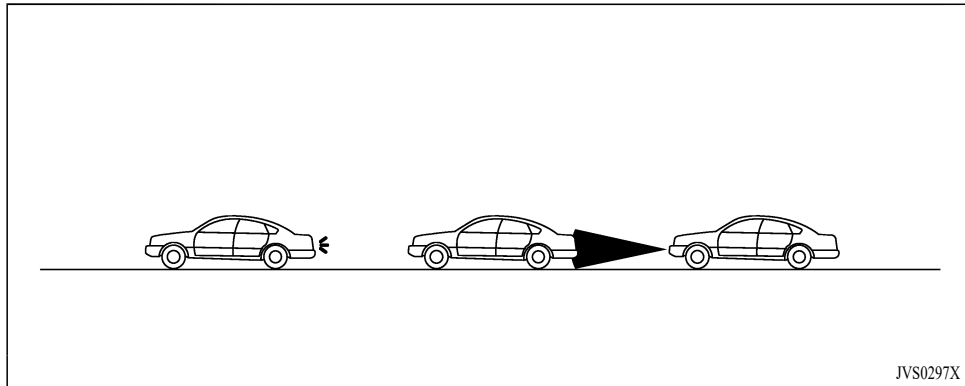
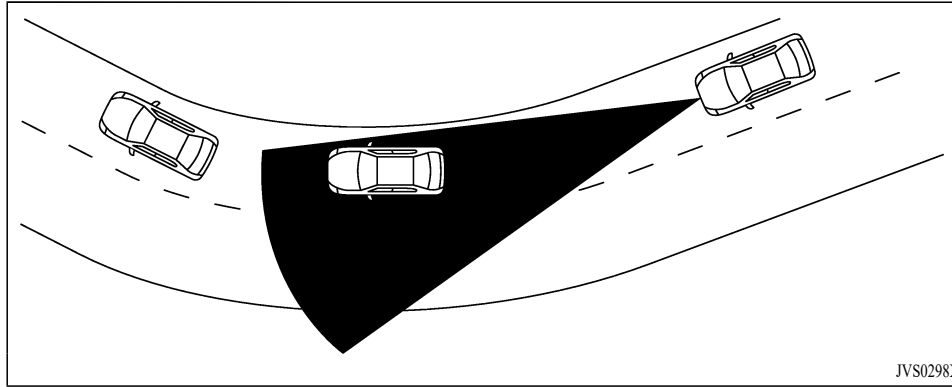

Illustration C

JVS0297X



JVS0298X

Illustration D

PFCW SYSTEM LIMITATIONS

WARNING

Listed below are the system limitations for the PFCW system. Failure to operate the vehicle in accordance with these system limitations could result in serious injury or death.

- The PFCW system cannot detect all vehicles under all conditions.
- The radar sensor does not detect the following objects:
 - Pedestrians, animals or obstacles in the roadway

- Oncoming vehicles
- Crossing vehicles

- (Illustration A) The PFCW system does not function when a vehicle ahead is a narrow vehicle, such as a motorcycle.
- The radar sensor may not detect a vehicle ahead in the following conditions:
 - Snow or heavy rain
 - Dirt, ice, snow or other material covering the radar sensor
 - Interference by other radar sources

- Snow or road spray from traveling vehicles.
- Driving in a tunnel
- Towing a trailer

- (Illustration B) When the vehicle ahead is being towed.
- (Illustration C) When the distance to the vehicle ahead is too close, the beam of the radar sensor is obstructed.
- (Illustration D) When driving on a steep downhill slope or roads with sharp curves.
- The system is designed to automatically check the sensor's functionality, within certain limitations. The system may not detect some forms of obstruction of the sensor area such as ice, snow, stickers, for example. In these cases, the system may not be able to warn the driver properly. Be sure that you check, clean and clear the sensor area regularly.
- Excessive noise will interfere with the warning chime sound, and the chime may not be heard.

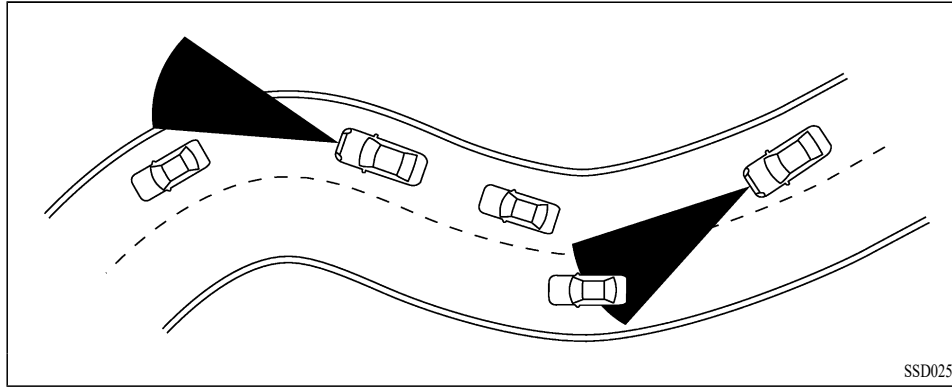

When driving on some roads, such as winding, hilly, curved, narrow roads, or roads which are under construction, the radar sensor may detect vehicles in a different lane, or may temporarily not detect a vehicle traveling ahead. This may cause the PFCW system to work inappropriately.

The detection of vehicles may also be affected by vehicle operation (steering maneuver or traveling position in the lane, etc.) or vehicle condition. **If this occurs, the system may warn you by blinking the vehicle ahead detection indicator and sounding the chime unexpectedly. You will have to manually control the proper distance away from the vehicle traveling ahead.**

SYSTEM TEMPORARILY UN-AVAILABLE

Condition A

When the radar sensor picks up interference from another radar source, making it impossible to detect a vehicle ahead, the PFCW system is automatically turned off. The FCM system OFF warning light (orange) will illuminate.

Action to take:

When the above conditions no longer exist, the PFCW system will resume automatically.

Condition B

Under the following conditions, making it impossible to detect a vehicle ahead, the PFCW system is automatically turned off.

The FCM system OFF warning light (orange) will illuminate and the “Forward Driving Aids temporarily disabled Front Sensor blocked” warning message will appear in the multi-information display.

- When the sensor area of the front of the vehicle is covered with dirt or is obstructed

Action to take:

If the FCM system warning light (orange) comes on, stop the vehicle in a safe place, push the park button to shift to the P (Park) position and turn the engine off. Clean the radar cover on the vehicle front area with a soft cloth, and restart the engine. If the warning light continues to illuminate, check that the cover of the sensor is not covered by dirt, snow or ice. If the warning light is still illuminated, have the PFCW system checked. It is recommended you visit an authorized Mitsubishi Motors dealer for this service.

- When driving on roads with limited road structures or buildings (for example, long bridges, deserts, snow fields, driving next to long walls)

Action to take:

When the above conditions no longer exist, the PFCW system will resume automatically.

SYSTEM MALFUNCTION

If the PFCW system malfunctions, it will be turned off automatically, a chime will sound, the FCM system warning light (orange) will illuminate and the warning message "Malfunction" will appear in the multi-information display.

Action to take:

If the warning light (orange) illuminates, stop the vehicle in a safe location. Turn the engine off and restart the engine. If the warning light continues to illuminate, have the PFCW system checked. It is recommended you visit an authorized Mitsubishi Motors dealer for this service.

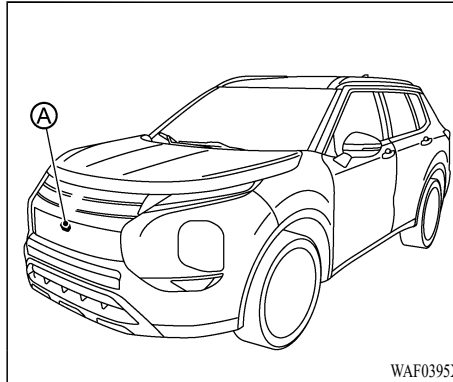
**SYSTEM MAINTENANCE**

The radar sensor ① is located on the front of the vehicle.

To keep the system operating properly, be sure to observe the following:

- Always keep the sensor area on the vehicle front area clean.
- Do not strike or damage the areas around the sensor.
- Do not cover or attach stickers or similar objects on the vehicle front area near the sensor area. This could cause failure or malfunction.

- Do not attach metallic objects near the sensor area (brush guard, etc.). This could cause failure or malfunction.
- Do not alter, remove or paint the front bumper. It is recommended you contact an authorized Mitsubishi Motors dealer before customizing or restoring the front bumper.

Radio frequency statement**For USA**

Type approval number:

FCC ID: NF3-FR5CPEC

User Manual statement according to §15.19:

This device complies with Part 15 of the FCC Rules.

Operation is subject to the following two conditions:

1. this device may not cause harmful interference, and
2. this device must accept any interference received, including interference that may cause undesired operation.

User Manual statement according to §15.21:

Changes or modifications made to this equipment not expressly approved by Robert BOSCH GmbH may void the FCC authorization to operate this equipment.

User Manual statement according to §15.105:

This equipment has been tested and found to comply with the limits for a Class A digital device, pursuant to Part 15 of the FCC Rules. These limits are designed to provide reasonable protection against harmful interference when the equipment is operated in a commercial environment. This equipment generates, uses, and can radiate radio frequency energy and, if not installed and used in accordance with the instruction manual, may cause harmful interference to radio communications. Operation of this equipment in a residential area is likely to cause harmful interference in which case the user will be required to correct the interference at his own expense.

RF Exposure Information according 2.1091/2.1093/OET bulletin 65:

Radio frequency radiation exposure information:

This equipment complies with FCC radiation exposure limits set forth for an uncontrolled environment. This equipment should be installed and operated with minimum distance of 20 cm between the radiator and your body.

The transmitter must not be co-located or operating in conjunction with any other antenna or transmitter.

For Canada

Type approval number:

IC: 3387A-FR5CPEC

Legal warning for RF equipment:

This device complies with Industry Canada licence-exempt RSS standard(s). Operation is subject to the following two conditions: (1) this device may not cause interference, and (2) this device must accept any interference, including interference that may cause undesired operation of the device.

Le présent appareil est conforme aux CNR d'Industrie Canada applicables aux appareils radio exempts de licence. L'exploitation est autorisée aux deux conditions suivantes: (1) l'appareil ne doit pas produire de brouillage, et (2) l'utilisateur de l'appareil doit accepter tout brouillage radioélectrique subi, même si le brouillage est susceptible d'en compromettre le fonctionnement.

DRIVER ATTENTION ALERT (DAA)

WARNING

Failure to follow the warnings and instructions for proper use of the DAA system could result in serious injury or death.

- **The DAA system is only a warning to inform the driver of a potential lack of driver attention or drowsiness. It will not steer the vehicle or prevent loss of control.**
- **The DAA system does not detect and provide an alert of the driver's lack of attention or fatigue in every situation.**
- **It is the driver's responsibility to:**
 - **stay alert.**
 - **drive safely.**
 - **keep the vehicle in the traveling lane.**
 - **be in control of the vehicle at all times.**
 - **avoid driving when tired.**
 - **avoid distractions (texting, etc).**

The DAA system helps alert the driver if the system detects a lack of attention or driving fatigue.

The system monitors driving style and steering behavior over a period of time, and it detects

Starting and driving 5-143

changes from the normal pattern. If the system detects that driver attention is decreasing over a period of time, the system uses audible and visual warnings to suggest that the driver take a break.

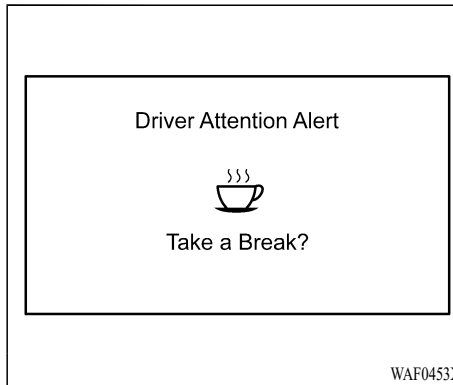

DAA SYSTEM OPERATION

If the system detects driver fatigue or that driver attention is decreasing, the message “Take a break?” appears in the multi-information display and a chime sounds when the vehicle is driven at speeds above 37 MPH (60 km/h).

The system continuously monitors driver attention and can provide multiple warnings per trip.

The system resets and starts reassessing driving style and steering behavior when the ignition switch is cycled from the ON to the OFF position and back to the ON position.

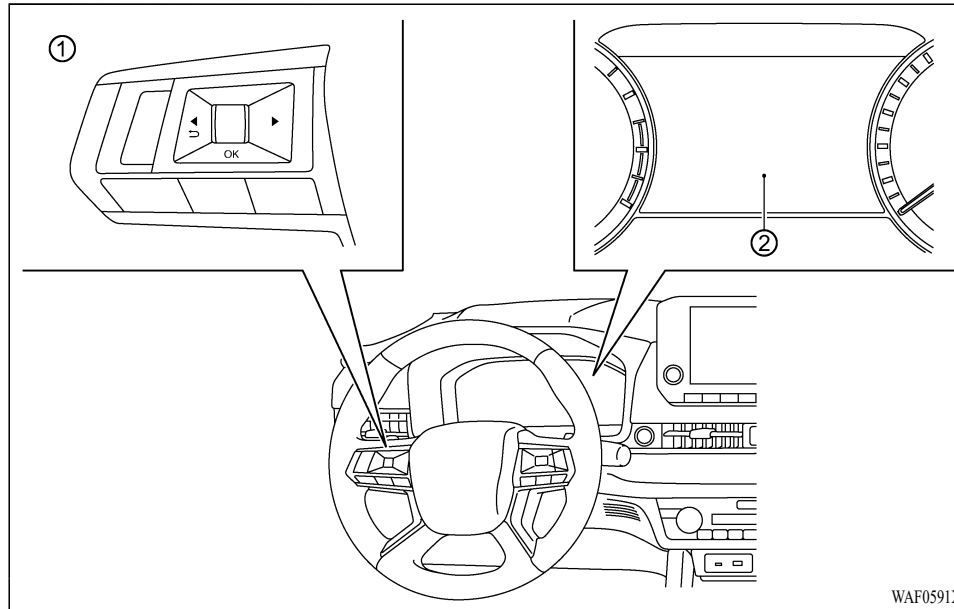

- ① Steering wheel remote control switches (left side)
- ② Multi-information display

HOW TO ENABLE/DISABLE THE DAA SYSTEM

Perform the following steps to enable or disable the DAA system.

1. Press the ◀ ▶ button until “Settings” displays in the multi-information display ②.

- Use the scroll dial to select “Driver Assistance.” Then push the scroll dial.
2. Select “Driver Attention Alert” and push the scroll dial to turn the system on or off.

NOTE:

The setting will be retained even if the engine is restarted.

DAA SYSTEM LIMITATIONS

WARNING

Listed below are the system limitations for the DAA system. Failure to operate the vehicle in accordance with these system limitations could result in serious injury or death.

- The DAA system may not operate properly and may not provide an alert in the following conditions:
 - Poor road conditions such as an uneven road surface or pot holes.
 - Strong side wind.
 - If you have adopted a sporty driving style with higher cornering speeds or higher rates of acceleration.
 - Frequent lane changes or changes to vehicle speed.

REAR AUTOMATIC EMERGENCY BRAKING (Rear AEB)

- The DAA system will not provide an alert in the following conditions:
 - Vehicle speeds lower than 37 MPH (60 km/h).
 - Short lapses of attention.
 - Instantaneous distractions such as dropping an object.

System malfunction

If the DAA system malfunctions, the “Driver Attention Alert Malfunction” warning message will appear in the multi-information display and the function will be stopped automatically.

Action to take

Stop the vehicle in a safe location, place the vehicle in P (Park) position, turn the engine off and restart the engine. If the system warning message continues to appear, have the system checked. It is recommended that you visit an authorized Mitsubishi Motors dealer for this service.

WARNING

Failure to follow the warnings and instructions for proper use of the Rear AEB system could result in serious injury or death.

- The Rear AEB system is a supplemental aid to the driver. It is not a replacement for proper driving procedures. Always use the side and rear mirrors and turn and look in the direction you will move before and while backing up. Never rely solely on the Rear AEB system. It is the driver's responsibility to stay alert, drive safely, and be in control of the vehicle at all times.
- There is a limitation to the Rear AEB system capability. The Rear AEB system is not effective in all situations.

The Rear AEB system can assist the driver when the vehicle is backing up and approaching objects directly behind the vehicle.

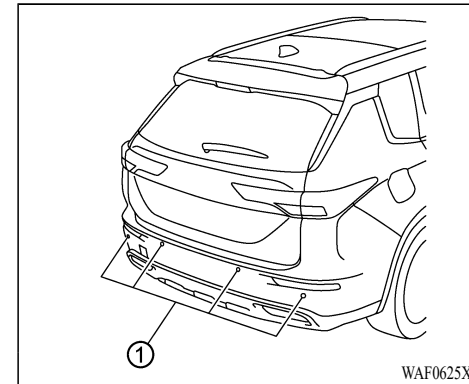

The Rear AEB system detects obstacles behind the vehicle using the rear parking sensor ① located on the rear bumper.

NOTE:

You can temporarily cancel the parking sensor function in the vehicle, but the Rear AEB system will continue to operate. For additional information, see “Rear parking sensor system” (P.5-169).

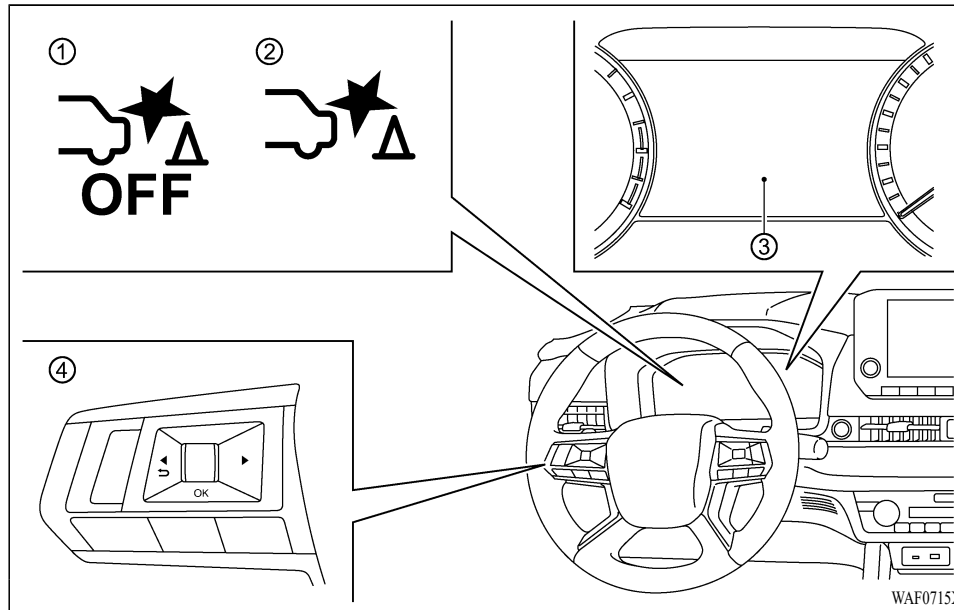

- ① Rear AEB system OFF warning light
- ② Rear AEB system warning indicator
- ③ Multi-information display
- ④ Steering wheel remote control switches (left side)

REAR AEB SYSTEM OPERATION

When the shift lever is in the R (Reverse) position and the vehicle speed is less than approximately 9 MPH (15 km/h), the Rear AEB system operates.

If a risk of a collision with an obstacle is detected when your vehicle is backing up, the Rear AEB system warning indicator ② will flash in the multi-information display ③ and the system will chime three times. The system will then automatically apply the brakes. After the automatic brake application, the driver must depress the brake pedal to maintain brake pressure.

NOTE:

- The stop lights of the vehicle come on when braking is performed by the Rear AEB system.
- When the brakes operate, a noise may be heard. This is not a malfunction.

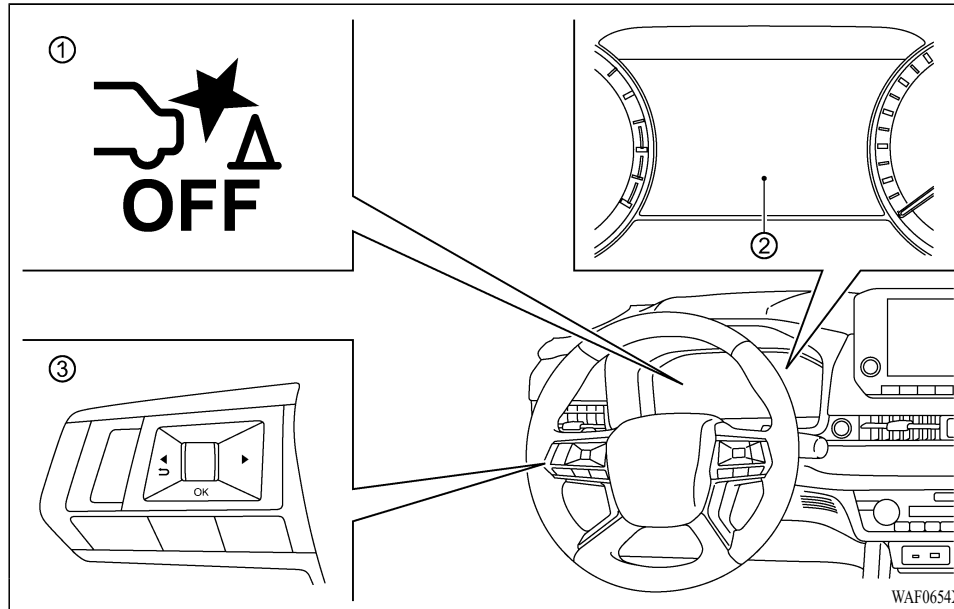

- ① Rear AEB system OFF warning light
- ② Multi-information display
- ③ Steering wheel remote control switches (left side)

TURNING THE REAR AEB SYSTEM ON/OFF

Perform the following steps to turn the Rear AEB system ON or OFF.

1. Press the ◀ ▶ button until “Settings” appears in the multi-information display ②

and then push the scroll dial. Use the scroll dial to select “Driver Assistance.” Then push the scroll dial.

2. Select “Emergency Brake” and push the scroll dial.

3. To set the Rear AEB system to on or off, use the scroll dial to check the box for “Rear”.

When the Rear AEB system is turned off, the Rear AEB system OFF warning light ① illuminates.

NOTE:

The Rear AEB system will be automatically turned on when the engine is restarted.

REAR AEB SYSTEM LIMITATIONS

⚠ WARNING

Listed below are the system limitations for the Rear AEB system. Failure to follow the warnings and instructions for proper use of the Rear AEB system could result in serious injury or death.

- When the vehicle approaches an obstacle while the accelerator or brake pedal is depressed, the function may not operate or the start of the operation may be delayed. The Rear AEB system may not operate or

may not perform sufficiently due to vehicle conditions, driving conditions, the traffic environment, the weather, road surface conditions, etc. Do not wait for the system to operate. Operate the brake pedal by yourself as soon as necessary.

- If it is necessary to override Rear AEB operation, strongly press the accelerator pedal.
- Always check your surroundings and turn to check what is behind you before and while backing up. The Rear AEB system detects stationary objects behind the vehicle. The Rear AEB system does not detect the following objects:
 - Moving objects
 - Low objects
 - Narrow objects
 - Wedge-shaped objects
 - Complex-shaped objects
 - Multiple object in close
 - Objects close to the bumper (less than approximately 1 ft [30 cm])
 - Objects that suddenly appear
 - Thin objects such as rope, wire, chain, etc.

- The Rear AEB system may not operate for pedestrians or animals.
- The Rear AEB system may not operate for the following obstacles:
 - Obstacles located high off the ground
 - Obstacles in a position offset from your vehicle
 - Obstacles, such as spongy materials or snow, that have soft outer surfaces and can easily absorb a sound wave
- The Rear AEB system may not operate in the following conditions:
 - There is rain, snow, ice, dirt, etc., attached to the parking sensors.
 - A loud sound is heard in the area around the vehicle.
 - The surface of the obstacle is diagonal to the rear of the vehicle.
 - The parking sensors or the area around them are extremely hot or cold.
- The Rear AEB system may unintentionally operate in the following conditions:
 - There is overgrown grass in the area around the vehicle.

- There is a structure (e.g., a wall, toll gate equipment, a narrow tunnel, a parking lot gate) near the side of the vehicle.
- There are bumps, protrusions, or manhole covers on the road surface.
- The vehicle drives through a draped flag or a curtain.
- The vehicle is driving on a steep hill.
- There is an accumulation of snow or ice behind the vehicle.
- An ultrasonic wave source, such as another vehicle's parking sensor, is near the vehicle.
- Once the automatic brake control operates, it does not operate again if the vehicle approaches the same obstacle.
- The automatic brake control can only operate for a short period of time. Therefore, the driver must depress the brake pedal.
- In the following situations, the Rear AEB system may not operate properly or may not function sufficiently:
 - The vehicle is driven in bad weather (rain, fog, snow, etc.).

- The vehicle is driven on a steep hill.
- The vehicle's posture is changed (e.g., when driving over a bump).
- The vehicle is driven on a slippery road.
- The vehicle is turned sharply by turning the steering wheel fully.
- Snow chains are used.
- Wheels or tires other than Mitsubishi Motors recommended are used.
- The brakes are cold at low ambient temperatures or immediately after driving has started.
- The braking force becomes poor due to wet brakes after driving through a puddle or washing the vehicle.
- Turn the Rear AEB system off in the following conditions to prevent the occurrence of an unexpected accident resulting from sudden system operation:
 - The vehicle is towed.
 - The vehicle is carried on a flatbed truck.

- The vehicle is on the chassis dynamometer.
- The vehicle drives on an uneven road surface.
- Suspension parts other than those designated as genuine parts are used. (If the vehicle height or the vehicle body inclination is changed, the system may not detect an obstacle correctly.)
- Excessive noise (e.g., audio system volume, an open vehicle window) will interfere with the chime sound, and it may not be heard.

NOTE:

If the Rear AEB system cannot be operated temporarily, the Rear AEB system warning light blinks.

SYSTEM MALFUNCTION

If the Rear AEB system malfunctions, it will be turned off automatically, the Rear AEB system warning light will illuminate, and the "Malfunction See Owner's Manual" warning message will appear in the multi-information display.

Action to take

If the warning light illuminates, park the vehicle in a safe location, turn the engine off, and restart the engine. If the warning light continues to illuminate, have the Rear AEB system checked. It is recommended that you visit an authorized Mitsubishi Motors dealer for this service.

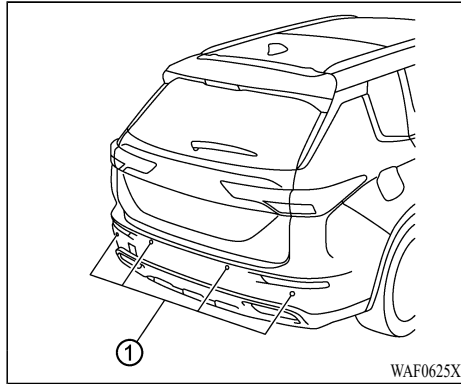

SYSTEM MAINTENANCE

Observe the following items to ensure proper operation of the system:

- Always keep the rear parking sensor ① clean.
- If the rear parking sensors are dirty, wipe them off with a soft cloth while being careful to not damage them.
- The parking sensors may be blocked by temporary ambient conditions such as splashing water, mist or fog. The blocked condition may also be caused by objects such as ice, frost or dirt obstructing the parking sensors. Check for and remove objects obstructing the area around the

parking sensors.

- Do not subject the area around the rear parking sensor ① to strong impact. Also, do not remove or disassemble the rear parking sensor. If the rear parking sensor and peripheral areas are deformed in an accident, etc., have the sensors checked. It is recommended that you visit an authorized Mitsubishi Motors dealer for this service.
- Do not attach stickers (including transparent stickers), accessories or apply additional paint on the rear parking sensor ① and their surrounding areas.
- When washing the vehicle using a high-pressure washer, do not apply direct washer pressure on the parking sensors. This may cause a malfunction of the parking sensors.

BREAK-IN SCHEDULE

CAUTION

During the first 1,200 miles (2,000 km), follow these recommendations to obtain maximum engine performance and ensure the future reliability and economy of your new vehicle. Failure to follow these recommendations may result in shortened engine life and reduced engine performance.

- Avoid driving for long periods at constant speed, either fast or slow. Do not run the engine over 4,000 rpm.
- Do not accelerate at full throttle in any gear.
- Avoid quick starts.
- Avoid hard braking as much as possible.
- Do not tow a trailer for the first 500 miles (800 km). Your engine, axle or other parts could be damaged.

FUEL EFFICIENT DRIVING TIPS

Follow these easy-to-use Fuel Efficient Driving Tips to help you achieve the most fuel economy from your vehicle.

1. Use smooth accelerator and brake pedal application.
 - Avoid rapid starts and stops.
 - Use smooth, gentle accelerator and brake application whenever possible.
 - Maintain constant speed while commuting and coast whenever possible.
2. Maintain constant speed.
 - Look ahead to try and anticipate and minimize stops.
 - Synchronizing your speed with traffic lights allows you to reduce your number of stops.
 - Maintaining a steady speed can minimize red light stops and improve fuel efficiency.
3. Use air conditioning (A/C) at higher vehicle speeds.
 - Below 40 MPH (64 km/h), it is more efficient to open windows to cool the vehicle due to reduced engine load.
 - Above 40 MPH (64 km/h), it is more efficient to use A/C to cool the vehicle due to increased aerodynamic drag.
 - Recirculating the cool air in the cabin when the A/C is on reduces cooling load.
4. Drive at economical speeds and distances.
 - Observing the speed limit and not exceeding 60 MPH (97 km/h) (where legally allowed) can improve fuel efficiency due to reduced aerodynamic drag.
 - Maintaining a safe following distance behind other vehicles reduces unnecessary braking.
 - Safely monitoring traffic to anticipate changes in speed permits reduced braking and smooth acceleration changes.
 - Select a gear range suitable to road conditions.
5. Use cruise control.
 - Using cruise control during highway driving helps maintain a steady speed.
 - Cruise control is particularly effective in providing fuel savings when driving on flat terrains.
6. Plan for the shortest route.
 - Utilize a map or navigation system to determine the best route to save time.
7. Avoid idling.
 - Shutting off your engine when safe for stops exceeding 30-60 seconds saves fuel and reduces emissions.
8. Buy an automated pass for toll roads.
 - Automated passes permit drivers to use special lanes to maintain cruising speed through the toll and avoid stopping and starting.
9. Winter warm up.
 - Limit idling time to minimize impact to fuel economy.
 - Vehicles typically need no more than 30 seconds of idling at start-up to effectively circulate the engine oil before driving.
 - Your vehicle will reach its ideal operating temperature more quickly while driving versus idling.
10. Keeping your vehicle cool.
 - Park your vehicle in a covered parking area or in the shade whenever possible.
 - When entering a hot vehicle, opening the windows will help to reduce the inside temperature faster, resulting in reduced demand on your A/C system.

INCREASING FUEL ECONOMY

- Keep your engine tuned up.
- Follow the recommended scheduled maintenance.
- Keep the tires inflated to the correct pressure. Low tire pressure increases tire wear and lowers fuel economy.
- Keep the wheels in correct alignment. Improper alignment increases tire wear and lowers fuel economy.
- Use the recommended viscosity engine oil. (See “Engine oil and oil filter recommendation” (P.10-5).)

S-AWC (Super-All Wheel Control) (if so equipped)

S-AWC is an integrated vehicle dynamics control system that helps enhance driving performance, cornering performance, and vehicle stability over a wide range of driving conditions through integrated management of the electronically controlled AWC, the AYC (Active Yaw Control), the ABS and the ASC.

CAUTION

Do not over-rely on the S-AWC. Even the S-AWC cannot prevent the natural laws of physics from acting on the vehicle. This system, like any other system, has limits and cannot help you to maintain traction and control of the vehicle in all circumstances. Reckless driving can lead to accidents. It is the driver's responsibility to drive carefully. This means taking into account the traffic, road and environmental conditions.

ELECTRONICALLY CONTROLLED AWC

The electronically controlled AWC is a system that improves acceleration performance and stability performance by controlling front-rear distribution of driving torque with operating the electronic control coupling arranged in the rear differential assembly.

When the electronically controlled AWC is

operating, especially GRAVEL, SNOW and MUD mode, you may feel a vibration or hear a noise from a underfloor. This is normal and indicates that the electronically controlled AWC is operating properly.

ACTIVE YAW CONTROL (AYC)

See “Chassis control” (P.5-160).

S-AWC OPERATION DISPLAY

The S-AWC operation status can be displayed on the information screen in the multi-information display.

To display the status, change the information screen.

(See “How to use the multi-information display” (P.2-21).)

Display example

The S-AWC operation status is displayed.

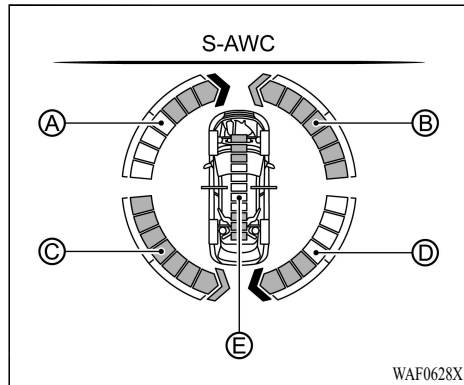

Yaw moment control display:

The amount of the yaw moment control is displayed as a bar graph.

Ⓐ, Ⓓ

Amount of the yaw moment control in a clockwise direction

Ⓑ, Ⓒ

Amount of the yaw moment control in a counterclockwise direction

Traction control:

The strength of the traction control between front and rear wheels is displayed in section Ⓔ of the meter as a bar graph.

⚠ WARNING

Always concentrate on your driving first. Keep your eyes and mind on the road. Distractions while driving can lead to an accident.

PARKING/PARKING ON HILLS

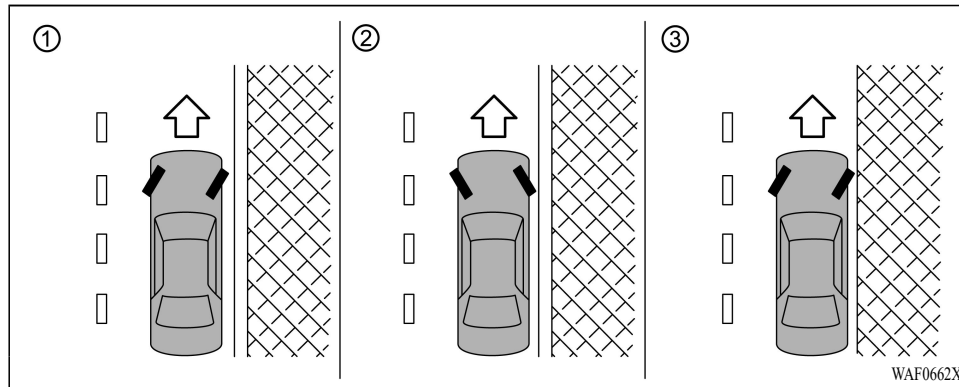

WARNING

- Do not stop or park the vehicle over flammable materials such as dry grass, waste paper or rags. They may ignite and cause a fire.
- Never leave the engine running while the vehicle is unattended.
- Do not leave children unattended inside the vehicle. They could unknowingly activate switches or controls. Unattended children could become involved in serious accidents.

- To help avoid risk of injury or death through unintended operation of the vehicle and/or its systems, do not leave children, people who require the assistance of others or pets unattended in your vehicle. Additionally, the temperature inside a closed vehicle on a warm day can quickly become high enough to cause a significant risk of injury or death to people and pets.
- Safe parking procedures require that both the parking brake be applied and the transmission placed into P (Park). Failure to do so could cause the vehicle to move unexpectedly or roll away and result in an accident.

- Make sure the shift lever cannot be moved without depressing the foot brake pedal.

1. Firmly apply the parking brake.
2. Push the park button to shift to the P (Park) position.
3. To help prevent the vehicle from rolling into the street when parked on a sloping drive way, it is a good practice to turn the wheels as illustrated.
 - HEADED DOWNHILL WITH CURB: ①
Turn the wheels into the curb and move the vehicle forward until the curb side wheel gently touches the curb.
 - HEADED UPHILL WITH CURB: ②
Turn the wheels away from the curb and move the vehicle back until the curb side wheel gently touches the curb.
 - HEADED UPHILL OR DOWNHILL, NO CURB: ③
Turn the wheels toward the side of the road so the vehicle will move away from the center of the road if it moves.
4. Place the ignition switch in the OFF position.

ELECTRIC POWER STEERING

WARNING

- If the engine is not running or is turned off while driving, the power assist for the steering will not work. Steering will be harder to operate.
- When the electric power steering warning light illuminates with the engine running, the power assist for the steering will cease operation. You will still have control of the vehicle but the steering will be harder to operate.

The electric power steering is designed to provide power assist while driving to operate the steering wheel with light force.

When the steering wheel is operated repeatedly or continuously while parking or driving at a very low speed, the power assist for the steering wheel will be reduced. This is to prevent overheating of the electric power steering and protect it from getting damaged. While the power assist is reduced, steering wheel operation will become heavy. When the temperature of the electric power steering goes down, the power assist level will return to normal. Avoid repeating such steering wheel operations that could cause the electric power steering to overheat.

You may hear a noise when the steering wheel

is operated quickly. However, this is not a malfunction.

If the electric power steering warning light  illuminates while the engine is running, it may indicate the electric power steering is not functioning properly and may need servicing. Have the electric power steering checked. It is recommended that you visit an authorized Mitsubishi Motors dealer for this service. (See “Electric power steering warning light” (P.2-16).)

When the electric power steering warning light illuminates with the engine running, the power assist for the steering will cease operation. You will still have control of the vehicle. However, greater steering effort is needed, especially in sharp turns and at low speeds.

The mode of the power steering will be changed automatically in accordance with the vehicle’s drive mode. (See “Drive Mode Selector” (P.5-28).)

BRAKE SYSTEM

BRAKING PRECAUTIONS

The brake system has two separate hydraulic circuits. If one circuit malfunctions, you will still have braking at two wheels.

Brake pedal

Overuse of the brake can cause weakening, resulting in poor brake response and premature wear of the brake pads.

When driving down a long or steep hill, use engine braking by downshifting.

WARNING

Do not leave any objects near the brake pedal or let a floor mat slide under it; doing so could prevent the full pedal stroke that would be necessary in an emergency. Make sure that the pedal can be operated freely at all times. Make sure the floor mat is securely held in place.

Vacuum assisted brakes

The brake booster aids braking by using engine vacuum. If the engine stops, you can stop the vehicle by depressing the brake pedal. However, greater foot pressure on the brake pedal will be required to stop the vehicle and the stopping distance will be longer.

Using the brakes

Avoid resting your foot on the brake pedal while driving. This will cause overheating of the brakes, wearing out the brake pads faster and reduce gas mileage.

To help reduce brake wear and to prevent the brakes from overheating, reduce speed and downshift to a lower gear before going down a slope or long grade. Overheated brakes may reduce braking performance and could result in loss of vehicle control.

WARNING

- While driving on a slippery surface, be careful when braking, accelerating or downshifting. Abrupt braking or accelerating could cause the wheels to skid and result in an accident.
- If the engine is not running or is turned off while driving, the power assist for the brakes will not work. Braking will be harder.

Wet brakes

When the vehicle is washed or driven through water, the brakes may get wet. As a result, your braking distance will be longer and the vehicle may pull to one side during braking.

To dry brakes, drive the vehicle at a safe speed while lightly tapping the brake pedal to heat-up the brakes. Do this until the brakes return to normal. Avoid driving the vehicle at high speeds until the brakes function correctly.

Parking brake break-in

Break in the parking brake shoes whenever the stopping effect of the parking brake is weakened or whenever the parking brake shoes and/or drums/rotors are replaced, in order to assure the best braking performance.

This procedure is described in the vehicle service manual. It is recommended you visit an authorized Mitsubishi Motors dealer for this service.

BRAKE ASSIST

BRAKE ASSIST

When the force applied to the brake pedal exceeds a certain level, the Brake Assist is activated generating greater braking force than a conventional brake booster even with light pedal force.

WARNING

The Brake Assist is only an aid to assist braking operation and is not a collision warning or avoidance device. It is the driver's responsibility to stay alert, drive safely and be in control of the vehicle at all times.

ANTI-LOCK BRAKING SYSTEM (ABS)

WARNING

- The Anti-lock Braking System (ABS) is a sophisticated device, but it cannot prevent accidents resulting from careless or dangerous driving techniques. It can help maintain vehicle control during braking on slippery surfaces. Remember that stopping distances on slippery surfaces will be longer than on normal surfaces even with ABS. Stopping distances may also be longer on rough, gravel or snow covered

roads, or if you are using tire chains. Always maintain a safe distance from the vehicle in front of you. Ultimately, the driver is responsible for safety.

- Tire type and condition may also affect braking effectiveness.
 - When replacing tires, install the specified size of tires on all four wheels.
 - For detailed information, see “Tires” (P.8-24) of this manual.

The Anti-lock Braking System (ABS) controls the brakes so the wheels do not lock during hard braking or when braking on slippery surfaces. The system detects the rotation speed at each wheel and varies the brake fluid pressure to prevent each wheel from locking and sliding. By preventing each wheel from locking, the system helps the driver maintain steering control and helps to minimize swerving and spinning on slippery surfaces.

Using the system

Depress the brake pedal and hold it down. Depress the brake pedal with firm steady pressure, but do not pump the brakes. The ABS will operate to prevent the wheels from locking up. Steer the vehicle to avoid obstacles.

5-158 Starting and driving



WARNING

Do not pump the brake pedal. Doing so may result in increased stopping distances.

Self-test feature

The ABS includes electronic sensors, electric pumps, hydraulic solenoids and a computer. The computer has a built-in diagnostic feature that tests the system each time you start the engine and move the vehicle at a low speed in forward or reverse. When the self-test occurs, you may hear a “clunk” noise and/or feel a pulsation in the brake pedal. This is normal and does not indicate a malfunction. If the computer senses a malfunction, it switches the ABS off and illuminates the ABS warning light on the instrument panel. The brake system then operates normally, but without anti-lock assistance.

If the ABS warning light illuminates during the self-test or while driving, have the vehicle checked. It is recommended you visit an authorized Mitsubishi Motors dealer for this service.

Normal operation

The ABS operates at speeds above 3 to 6 MPH (5 to 10 km/h). The speed varies according to road conditions.

When the ABS senses that one or more wheels are close to locking up, the actuator rapidly applies and releases hydraulic pressure. This action is similar to pumping the brakes very quickly. You may feel a pulsation in the brake pedal and hear a noise from under the hood or feel a vibration from the actuator when it is operating. This is normal and indicates that the ABS is operating properly. However, the pulsation may indicate that road conditions are hazardous and extra care is required while driving.

ACTIVE STABILITY CONTROL (ASC)

The Active stability control (ASC) uses various sensors to monitor driver inputs and vehicle motion. Under certain driving conditions, the ASC helps to perform the following functions.

- Controls brake pressure to reduce wheel slip on one slipping drive wheel so power is transferred to a non slipping drive wheel on the same axle.
- Controls brake pressure and engine output to reduce drive wheel slip based on vehicle speed (traction control function).
- Controls brake pressure at individual wheels and engine output to help the driver maintain control of the vehicle in the following conditions:
 - understeer (vehicle tends to not follow the steered path despite increased steering input)
 - oversteer (vehicle tends to spin due to certain road or driving conditions).



The ASC can help the driver to maintain control of the vehicle, but it cannot prevent loss of vehicle control in all driving situations.

When the ASC operates, the ASC warning light  in the instrument panel flashes so note the following:

- The road may be slippery or the system may determine some action is required to help keep the vehicle on the steered path.

- You may feel a pulsation in the brake pedal and hear a noise or vibration from under the hood. This is normal and indicates that the ASC is working properly.
- Adjust your speed and driving to the road conditions.

If a malfunction occurs in the system, the ASC warning light  illuminates in the instrument panel. The ASC automatically turns off.



The multi-information display is used to turn off the ASC. The ASC off indicator  illuminates to indicate the ASC is off. When the ASC is turned off, the ASC still operates to prevent one drive wheel from slipping by transferring power to a non slipping drive wheel. The ASC warning light  flashes if this occurs. All other ASC functions are off, and the ASC warning light  will not flash. The ASC is automatically reset to on when the ignition switch is placed in the off position then back to the on position.

See “Active stability control (ASC) warning light” (P.2-16) and “Active stability control (ASC) off indicator light” (P.2-16).



The computer has a built-in diagnostic feature that tests the system each time you start the engine and move the vehicle forward or in reverse at a slow speed. When the self-test occurs, you may hear a “clunk” noise and/or feel a pulsation in the brake pedal. This is

normal and is not an indication of a malfunction.

WARNING

- The ASC is designed to help improve driving stability but does not prevent accidents due to abrupt steering operation at high speeds or by careless or dangerous driving techniques. Reduce vehicle speed and be especially careful when driving and cornering on slippery surfaces and always drive carefully.
- Do not modify the vehicle’s suspension. If suspension parts such as shock absorbers, struts, springs, stabilizer bars, bushings and wheels are not Mitsubishi Motors recommended for your vehicle or are extremely deteriorated, the ASC may not operate properly. This could adversely affect vehicle handling performance, and the ASC warning light  may illuminate.
- If brake related parts such as brake pads, rotors and calipers are not Mitsubishi Motors recommended or are extremely deteriorated, the ASC may not operate properly and the ASC warning light  may illuminate.
- If engine control related parts are not Mitsubishi Motors recommended or are extremely deteriorated, the ASC warning

light  may illuminate.

- When driving on extremely inclined surfaces such as higher banked corners, the ASC may not operate properly and the ASC warning light  may illuminate. Do not drive on these types of roads.
- When driving on an unstable surface such as a turntable, ferry, elevator or ramp, the ASC warning light  may illuminate. This is not a malfunction. Restart the engine after driving onto a stable surface.
- If wheels or tires other than the Mitsubishi Motors recommended ones are used, the ASC may not operate properly and the ASC warning light  may illuminate.
- The ASC is not a substitute for winter tires or tire chains on a snow covered road.

HOW TO TURN OFF THE ASC

The vehicle should be driven with the Active stability control (ASC) ON for most driving conditions.

When the vehicle is stuck in mud or snow, the ASC reduces the engine output to reduce wheel spin. The engine speed will be reduced even if the accelerator is depressed to the floor. If maximum engine power is needed to free a stuck vehicle, turn the ASC off.

5-160 Starting and driving

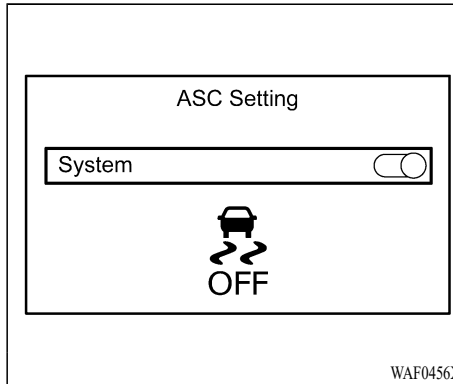

Example

To turn off the ASC, perform the following steps in the multi-information display.

1. Push the ◀ ▶ button on the left-side of the steering wheel until “Settings” is displayed.
2. Use the scroll dial to select “ASC Setting” and then push it.
3. Select “System” and push the scroll dial. The  indicator light will illuminate.

Turn “ASC Setting” back on in the multi-information display or restart the engine to turn on the ASC.

CHASSIS CONTROL

The chassis control is an electric control module that includes the following functions:

- Active Yaw Control (AYC)
- Active Ride Control

ACTIVE YAW CONTROL (AYC)

This system enhances vehicle cornering performance and vehicle stability with management of vehicle turning power (yaw moment) by controlling the drive power difference of the left and right wheels and the braking force when the vehicle does not turn in response to steering input, such as when the steering wheel is turned quickly or when driving on slippery road.

When the ASC system is turned off, AYC is also turned off.

Amount of brake control is changed based on Drive Mode selector switch.

When AYC is not functioning properly, the master warning light illuminates, and warning message “Chassis control” will also appear in the multi-information display.

If the chassis control warning message appears in the multi-information display, it may indicate that AYC is not functioning properly. Have the system checked as soon as possible. It is recommended that you visit an authorized Mitsubishi Motors dealer for this service. (See “Multi-information display warnings and indi-

cators” (P.2-33.)

WARNING

AYC does not enhance the stopping performance of the vehicle, therefore, pay careful attention to the safety of your surroundings when driving.

When AYC is operating, you may feel a pulsation in the brake pedal, sense slight deceleration, or hear a noise. This is normal and indicates that AYC is operating properly.

ACTIVE RIDE CONTROL

This system senses upper body motion and controls four wheel brake pressure. This will enhance ride comfort in effort to restrain uncomfortable upper body movement when passing over undulated road surfaces. When the ASC system is turned off, the Active Ride Control is also turned off.

If the chassis control warning message appears in the multi-information display, it may indicate that the Active Ride Control is not functioning properly. Have the system checked as soon as possible. It is recommended that you visit an authorized Mitsubishi Motors dealer for this service.

WARNING

The Active Ride Control may not be effective depending on the driving condition. Always drive carefully and attentively.

When the Active Ride Control is operating, you may feel a pulsation in the brake pedal, sense slight deceleration, or hear a noise. This is normal and indicates that Active Ride Control is operating properly.

WARNING

- Never rely solely on the Hill Start Assist (HSA) to prevent the vehicle from moving backward on a hill. Always drive carefully and attentively. Depress the brake pedal when the vehicle is stopped on a steep hill. Be especially careful when stopped on a hill on frozen or muddy roads. Failure to prevent the vehicle from rolling backwards may result in a loss of control of the vehicle and possible serious injury or death.
- The Hill Start Assist (HSA) is not designed to hold the vehicle at a standstill on a hill. Depress the brake pedal when the vehicle is stopped on a steep hill. Failure to do so may cause the vehicle to roll backwards and may result in a collision or serious personal injury.
- The Hill Start Assist (HSA) may not prevent the vehicle from rolling backwards on a hill under all load or road conditions. Always be prepared to depress the brake pedal to prevent the vehicle from rolling backwards. Failure to do so may result in a collision or serious personal injury.

The Hill Start Assist (HSA) automatically keeps the brakes applied to help prevent the vehicle from rolling backwards in the time it takes the driver to release the brake pedal and apply the accelerator when the vehicle is stopped on a

Starting and driving 5-161

hill.

The Hill Start Assist (HSA) will operate automatically under the following conditions:

- The transmission is shifted to a forward or reverse gear.
- The vehicle is stopped completely on a hill by applying the brake.

The maximum holding time is 2 seconds. After 2 seconds the vehicle will begin to roll back and the Hill Start Assist (HSA) will stop operating completely.

The Hill Start Assist (HSA) will not operate when the transmission is shifted to the N (Neutral) or P (Park) position or on a flat and level road.

When the Active stability control (ASC) warning light illuminates in the meter, the Hill Start Assist (HSA) will not operate. (See “Active stability control (ASC) warning light” (P.2-16).)

HILL DESCENT CONTROL (HDC)

The Hill Descent Control (HDC) is the system that assists the steady driving with the constant speed when descending steep grades where it is impossible to decelerate the vehicle sufficiently by the engine brake only or rough roads.

WARNING

- Never rely solely on the Hill Descent Control (HDC) to control vehicle speed when driving on steep downhill grades. Always drive carefully when using the Hill Descent Control (HDC) and decelerate the vehicle speed by depressing the brake pedal if necessary. Be especially careful when driving on frozen, muddy or extremely steep downhill roads. Failure to control vehicle speed may result in a loss of control of the vehicle and possible serious injury or death.
- The Hill Descent Control (HDC) may not control the vehicle speed on a hill under all load or road conditions. For example, when driving slippery roads such as muddy, icy or unpaved roads, the vehicle will not allow you to stay at a certain low speed, which may lead to a serious accident. Always be prepared to depress the brake pedal to control vehicle speed. Failure to do so may result in a collision or serious personal injury.

CAUTION

When there is a malfunction in the Hill Descent Control (HDC) system, ASC warning light comes on. When ASC warning light comes on, have the vehicle inspected at an authorised MITSUBISHI MOTORS dealer. (See “Active stability control (ASC) warning light” (P.2-16).)

When the warning light comes on, the warning display may also appear.

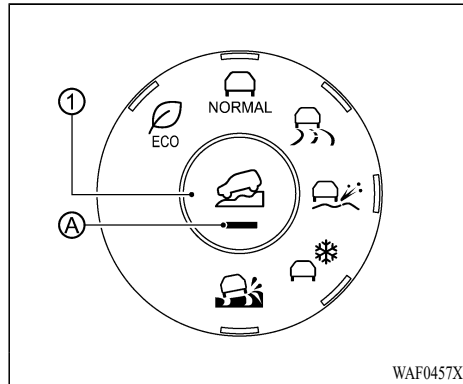

TO OPERATE

1. Bring the vehicle to a complete stop.
2. Press the Hill Descent Control switch ①.
3. Make sure that the Hill Descent Control indicator ② blinks or illuminates.

When the Hill Descent Control indicator ② blinks or illuminates, the Hill Descent Control set to ON (Stand by).

NOTE:

- The indicator should illuminate when the operation mode is put in ON and should go off after a few seconds.
- It is impossible to set the Hill Descent Control to ON (Stand by) in the following

conditions:

- Brake system: brake temperature high
- ASC warning light illuminating or blinking (See “Active stability control (ASC) warning light” (P.2-16).)

In the following cases, the Hill Descent Control brake control operates:

- The vehicle shift is in the D (Drive) or R (Reverse) position.
- Vehicle speed: 15 MPH (25 km/h) or less
- The accelerator pedal or the brake pedal is not operated.

When the control operates, the Hill Descent Control indicator illuminates and the brake light and the high-mounted stop light are illuminated. It is possible to change the controlled vehicle speed by operating the accelerator pedal or brake pedal.

When you lift your foot off the pedal, the Hill Descent Control performs brake control so as to keep the vehicle speed at that time.

NOTE:

- The Hill Descent Control will not operate even if the Hill Descent Control is in ON (Stand by), and the control will temporarily stop during the activation of it in the following condition:

- Vehicle speed exceeds 15 MPH (25 km/h)

- When the Hill Descent Control is activated, you may feel the vehicle body, the steering wheel and the brake pedal vibrate and hear the operation noise. You may also feel the depressed brake pedal is solid or loose. This does not indicate a malfunction and the Hill Descent Control is operating normally.
- The Hill Descent Control indicator illuminates on a flat road, but this does not indicate a malfunction.

TO DEACTIVATE

1. Press the Hill Descent Control switch. The Hill Descent Control will be gradually released.
2. Make sure that the Hill Descent Control indicator ② is OFF.

NOTE:

The Hill Descent Control turns off automatically and the Hill Descent Control indicator goes off without pressing the Hill Descent Control switch in the following conditions:

- ASC warning light: ON
- Brake system: brake temperature high

PARKING SENSOR SYSTEM (if so equipped)

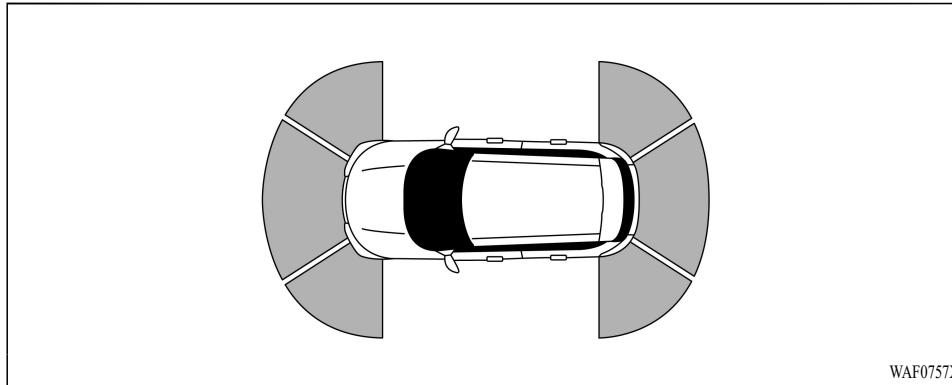

WAF0757X

Example

The parking sensor system sounds a tone to inform the driver of obstacles around the vehicle using the parking sensors located in the front and rear bumpers.

When the “Auto Show Sonar” key is on, the parking sensor view will automatically appear in the multi-information display.

WARNING

- The parking sensor system is a convenience but it is not a substitute for proper parking.

- The driver is always responsible for safety during parking and other maneuvers. Always look around and check that it is safe to do so before parking.
- Read and understand the limitations of the parking sensor system as contained in this section. The colors of the parking sensor indicator indicates different distances to the object.
- Inclement weather or ultrasonic sources such as an automatic car wash, a truck's compressed-air brakes or a pneumatic drill may affect the function of the system; this may include reduced performance or a false activation.

- The parking sensor system is designed as an aid to the driver in detecting large stationary objects to help avoid damaging the vehicle.
- The parking sensor system is not designed to prevent contact with small or moving objects. Always move slowly. The system will not detect small objects below the bumper/vehicle side, and may not detect objects close to the bumper/vehicle side or on the ground.
- The parking sensor system may not detect the following objects: fluffy objects such as snow, cloth, cotton, glass, wool, etc.; thin objects such as rope, wire and chain, etc.; or wedge-shaped objects.

If your vehicle sustains damage to the bumper fascia, leaving it misaligned or bent, the sensing zone may be altered causing inaccurate measurement of obstacles or false alarms.

CAUTION

- Excessive noise (such as audio system volume or an open vehicle window) will interfere with the tone and it may not be heard.
- Keep the parking sensors (located on the bumper fascia) free from snow, ice and large accumulations of dirt. Do not clean

the sensors with sharp objects. If the sensors are covered, the accuracy of the parking sensor function will be diminished.

SYSTEM OPERATION

The system informs with a visual and audible alert of:

- front obstacles when the shift lever is in the D (Drive) position
- front and rear obstacles when the shift lever is in the R (Reverse) position

The system is deactivated at speeds above 6 MPH (10 km/h). It is reactivated at lower speeds.

When the object is detected, the indicator (green) appears and blinks and the tone sounds intermittently. When the vehicle moves closer to the object, the color of the indicator turns yellow and the rate of the blinking increases. When the vehicle is very close to the object, the indicator stops blinking and turns red, and the tone sounds continuously.

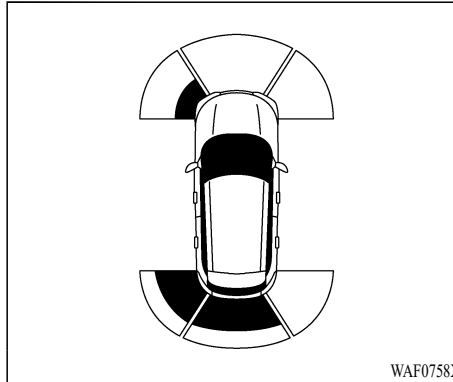

Example

When the vehicle moves closer to an obstacle, the parking sensor indicator (detected area) appears on the multi-information display.

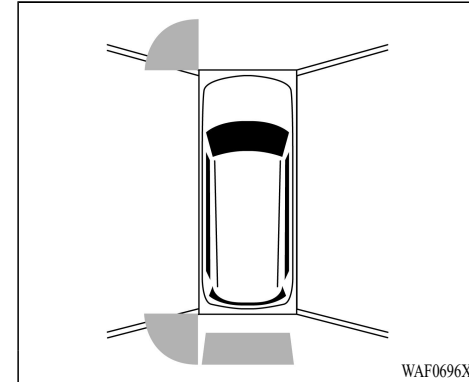

Example

The parking sensor indicator also appears on the Multi Around Monitor view of Smartphone-link Display Audio (SDA) screen.

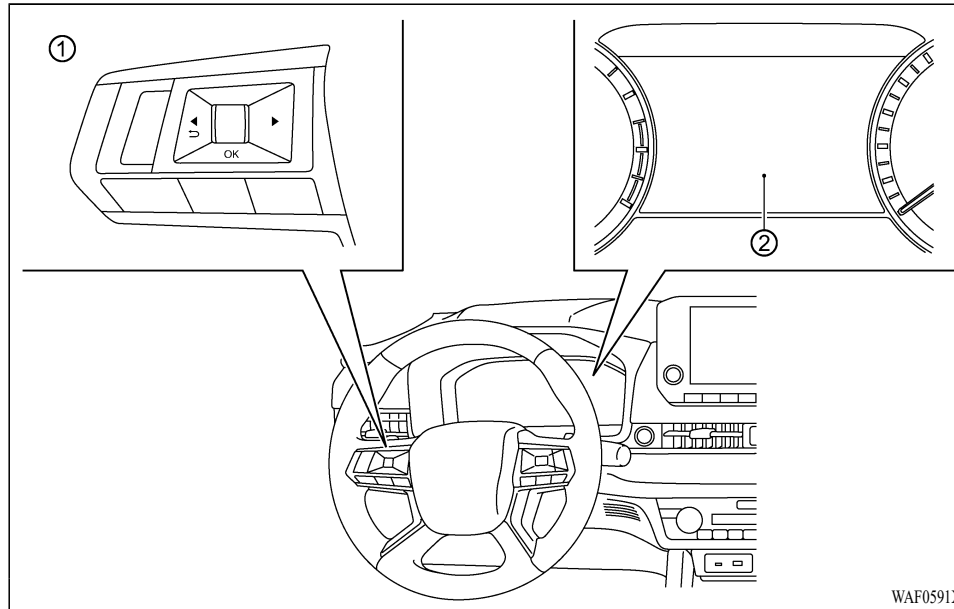

- ① Steering wheel remote control switches (left side)
- ② Multi-information display

HOW TO ENABLE/DISABLE THE PARKING SENSOR SYSTEM

The system is automatically activated when the ignition switch is in the ON position and the shift lever is in the D (Drive) or R (Reverse)

position.

Perform the following steps to set up the parking sensor function.

1. Press the ◀ ▶ button until “Settings” appears in the multi-information display ② and then push the scroll dial. Use the scroll dial to select “Driver Assistance.” Then push the scroll dial.
2. Select “Parking sensors” and push the scroll dial.
3. Use the scroll dial to navigate in the menu and select or change an item:
 - Moving Object
 - Turns ON/OFF the Moving Object Detection (MOD) (See “Moving Object Detection (MOD)” (P.4-23).)
 - Auto Show Sonar
 - Shows the parking sensor display in the multi-information display when the parking sensor activates
 - Front
 - Turns ON/OFF the front parking sensor
 - Rear
 - Turns ON/OFF the rear parking sensor
 - Distance
 - Changes the parking sensor distance to “Long,” “Medium” or “Short”

- Volume
 - Changes the volume of the tone sound to “High,” “Medium” or “Low”

PARKING SENSOR SYSTEM LIMITATIONS

WARNING

Listed below are the system limitations for the parking sensor system. Failure to operate the vehicle in accordance with these system limitations could result in serious injury or death.

- Read and understand the limitations of the parking sensor system as contained in this section. Inclement weather may affect the function of the parking sensor system; this may include reduced performance or a false activation.
- The parking sensor system is deactivated at speeds above 6 MPH (10 km/h). It is reactivated at lower speeds.
- Inclement weather or ultrasonic sources such as an automatic car wash, a truck’s compressed-air brakes or a pneumatic drill may affect the function of the parking sensor system; this may include reduced performance or a false activation.
- The parking sensor system is not designed to prevent contact with small or moving objects. Always move slowly. The system will not detect small objects below the

bumper or on the ground.

- The parking sensor system may not detect the following objects: fluffy objects such as snow, cloth, cotton, glass-wool, etc.; thin objects such as rope, wire and chain, etc.; or wedge-shaped objects; complex-shaped objects or multiple objects in close.
- The parking sensor system may not detect objects at speed above 3 MPH (5 km/h) and may not detect certain angular or moving objects.
- The parking sensor system may not detect the following objects:
 - Pedestrians who approach the vehicle from the side
 - Objects placed next to the vehicle
- The parking sensor system may not operate in the following conditions:
 - When rain, snow, ice, dirt, etc. adheres to the parking sensor.
 - When a loud sound is heard in the area around the vehicle.
 - When the surface of the obstacle is diagonal to the front or rear of the vehicle.
 - When a parking sensor or the area around the sensor is extremely hot or cold.

- The parking sensor system may unintentionally operate in the following conditions:

- When there is overgrown grass in the area around the vehicle.
- When there is a structure (for example, a wall, a toll gate equipment, a narrow tunnel or a parking lot gate) near the side of the vehicle.
- When there are bumps, protrusions or manhole covers on the road surface.
- When the vehicle drives through a draped flag or a curtain.
- When there is an accumulation of snow or ice behind the vehicle.
- When driving on a steep hill.

SYSTEM TEMPORARILY UNAVAILABLE

When parking sensor blockage is detected, the system will be deactivated automatically.

The system is not available until the conditions no longer exist.

The parking sensors may be blocked by temporary ambient conditions such as splashing

Starting and driving 5-167

water, mist or fog. The blocked condition may also be caused by objects such as ice, frost or dirt obstructing the parking sensors.

Action to take:

When the above conditions no longer exist, the system will resume automatically.

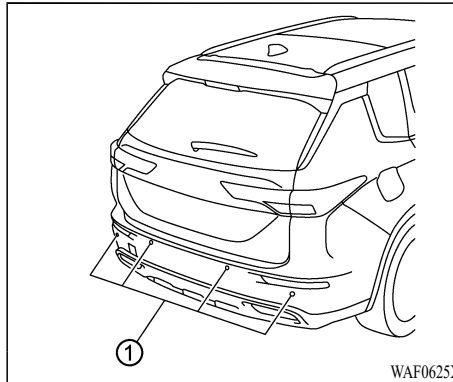
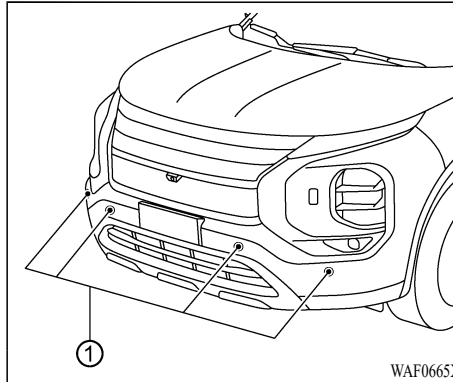

SYSTEM MAINTENANCE

The parking sensors ① are located on the front and rear bumpers. Always keep the area near the parking sensors clean.

If the parking sensors are dirty, wipe them off with a soft cloth while being careful to not damage them.

The parking sensors may be blocked by temporary ambient conditions such as splashing water, mist or fog.

The blocked condition may also be caused by objects such as ice, frost or dirt obstructing the parking sensors.

Check for and remove objects obstructing the area around the parking sensors.

Do not attach stickers (including transparent material), install accessories or apply additional paint on the parking sensors and their surrounding areas. This may cause a malfunction or improper operation.

Do not subject the area around the parking sensors to strong impact. Also, do not remove or disassemble the parking sensors. If the parking sensors and peripheral areas are deformed in an accident, etc., have the parking sensors checked. It is recommended that you visit an authorized Mitsubishi Motors dealer for this service.

REAR PARKING SENSOR SYSTEM (if so equipped)

When washing the vehicle using a high-pressure washer, do not apply direct washer pressure on the parking sensors. This may cause a malfunction of the parking sensors.

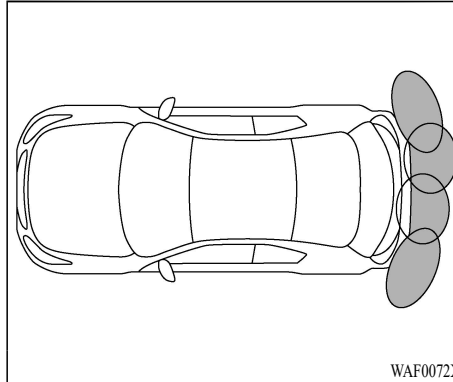

The rear parking sensor sounds a tone to inform the driver of obstacles near the rear bumper.

When the “Auto Show Sonar” key is on, the parking sensor view will automatically appear in the multi-information display.

WARNING

- The rear parking sensor is a convenience but it is not a substitute for proper parking.
- The driver is always responsible for safety during parking and other maneuvers. Always look around and check that it is safe to do so before parking.

- Read and understand the limitations of the rear parking sensor as contained in this section. The colors of the parking sensor indicator indicates different distances to the object.
- Inclement weather or ultrasonic sources such as an automatic car wash, a truck’s compressed-air brakes or a pneumatic drill may affect the function of the system; this may include reduced performance or a false activation.
- The rear parking sensor is designed as an aid to the driver in detecting large stationary objects to help avoid damaging the vehicle.
- The rear parking sensor is not designed to prevent contact with small or moving objects. Always move slowly. The system will not detect small objects below the bumper, and may not detect objects close to the bumper or on the ground.
- The rear parking sensor may not detect the following objects: fluffy objects such as snow, cloth, cotton, glass, wool, etc.; thin objects such as rope, wire and chain, etc.; or wedge-shaped objects.

If your vehicle sustains damage to the bumper fascia, leaving it misaligned or bent, the sensing zone may be altered causing inaccurate measurement of obstacles or false alarms.

CAUTION

- Excessive noise (such as audio system volume or an open vehicle window) will interfere with the tone and it may not be heard.
- Keep the parking sensors (located on the rear bumper fascia) free from snow, ice and large accumulations of dirt. Do not clean the sensors with sharp objects. If the sensors are covered, the accuracy of the parking sensor function will be diminished.

SYSTEM OPERATION

The system informs with a visual and audible alert of rear obstacles when the shift lever is in the R (Reverse) position.

The system is deactivated at speeds above 6 MPH (10 km/h). It is reactivated at lower speeds.

When the object is detected, the indicator (green) appears and blinks and the tone sounds intermittently. When the vehicle moves closer to the object, the color of the indicator turns yellow and the rate of the blinking increases. When the vehicle is very close to the object, the indicator stops blinking and turns red, and the tone sounds continuously.

5-170 Starting and driving

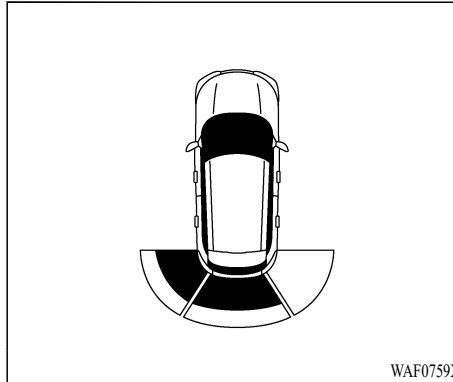

Example

When the rear of the vehicle moves closer to an obstacle, the parking sensor indicator appears in the multi-information display.

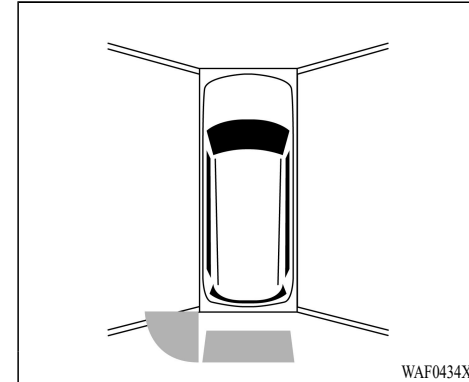

Example

The parking sensor indicator also appears on the Multi Around Monitor view of Smartphone-link Display Audio (SDA) screen.

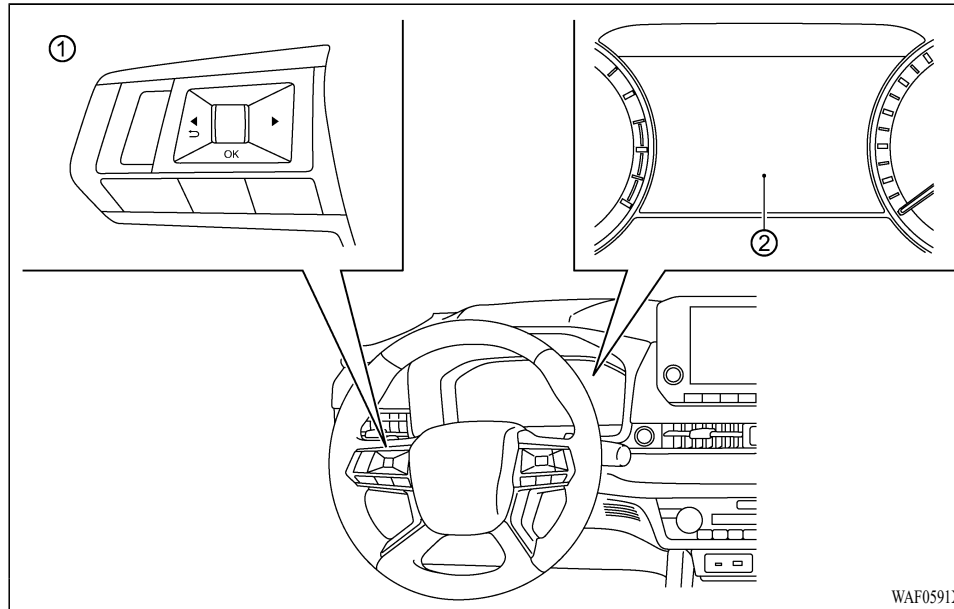

- ① Steering wheel remote control switches (left side)
 ② Multi-information display

HOW TO ENABLE/DISABLE THE REAR PARKING SENSOR

The system is automatically activated when the ignition switch is in the ON position and the shift lever is in the R (Reverse) position.

Perform the following steps to enable or disable

the rear parking sensor:

1. Press the ◀ ▶ button until “Settings” appears in the multi-information display ② and then push the scroll dial. Use the scroll dial to select “Driver Assistance.” Then push the scroll dial.
2. Select “Parking sensors” and push the scroll dial.
3. Use the scroll dial to navigate in the menu and select or change an item:
 - Moving Object (if so equipped)
 - Turns ON/OFF the Moving Object Detection (MOD) (See “Moving Object Detection (MOD)” (P.4-23).)
 - Auto Show Sonar
 - Shows the parking sensor display in the multi-information display when the rear parking sensor activates
 - Rear
 - Turns ON/OFF the rear parking sensor
 - Distance
 - Changes the rear parking sensor’s detection distance to “Long,” “Medium” or “Short”
 - Volume
 - Changes the volume of the tone sound to “High,” “Medium” or “Low”

REAR PARKING SENSOR LIMITATIONS

WARNING

Listed below are the rear parking sensor limitations for the parking sensor system. Failure to operate the vehicle in accordance with these system limitations could result in serious injury or death.

- Read and understand the limitations of the rear parking sensor as contained in this section. Inclement weather may affect the function of the rear parking sensor; this may include reduced performance or a false activation.
- The system is deactivated at speeds above 6 MPH (10 km/h). It is reactivated at lower speeds.
- Inclement weather or ultrasonic sources such as an automatic car wash, a truck's compressed-air brakes or a pneumatic drill may affect the function of the rear parking sensor; this may include reduced performance or a false activation.
- Rear parking sensor is not designed to prevent contact with small or moving objects. Always move slowly. The system will not detect small objects below the bumper or on the ground.

- Rear parking sensor may not detect the following objects: fluffy objects such as snow, cloth, cotton, glass-wool, etc.; thin objects such as rope, wire and chain, etc.; or wedge-shaped objects; complex-shaped objects or multiple objects in close.
- Rear parking sensor may not detect objects at speed above 3 MPH (5 km/h) and may not detect certain angular or moving objects; complex-shaped objects or multiple objects in close.
- The rear parking sensor system may not operate in the following conditions:
 - When rain, snow, ice, dirt, etc. adheres to the parking sensor.
 - When a loud sound is heard in the area around the vehicle.
 - When the surface of the obstacle is diagonal to the rear of the vehicle.
 - When a parking sensor or the area around the sensor is extremely hot or cold.
- The parking sensor system may unintentionally operate in the following conditions:
 - When there is overgrown grass in the area around the vehicle.

- When there are bumps, protrusions or manhole covers on the road surface.
- When the vehicle drives through a draped flag or a curtain.
- When there is an accumulation of snow or ice behind the vehicle.
- When driving on a steep hill.

SYSTEM TEMPORARILY UNAVAILABLE

When parking sensor blockage is detected, the system will be deactivated automatically.

The system is not available until the conditions no longer exist.

The parking sensors may be blocked by temporary ambient conditions such as splashing water, mist or fog. The blocked condition may also be caused by objects such as ice, frost or dirt obstructing the parking sensors.

Action to take:

When the above conditions no longer exist, the system will resume automatically.

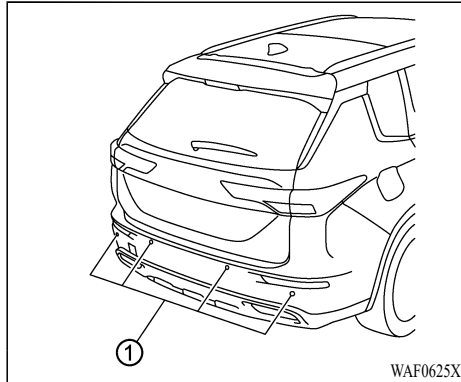

SYSTEM MAINTENANCE

The parking sensors ① are located on the rear bumper. Always keep the area near the parking sensors clean.

If the parking sensors are dirty, wipe them off with a soft cloth while being careful to not damage them.

The parking sensors may be blocked by temporary ambient conditions such as splashing water, mist or fog.

The blocked condition may also be caused by objects such as ice, frost or dirt obstructing the parking sensors.

Check for and remove objects obstructing the

area around the parking sensors.

Do not attach stickers (including transparent material), install accessories or apply additional paint on the parking sensors and their surrounding areas. This may cause a malfunction or improper operation.

Do not subject the area around the parking sensors to strong impact. Also, do not remove or disassemble the parking sensors. If the parking sensors and peripheral areas are deformed in an accident, etc., have the parking sensors checked. It is recommended that you visit an authorized Mitsubishi Motors dealer for this service.

When washing the vehicle using a high-pressure washer, do not apply direct washer pressure on the parking sensors. This may cause a malfunction of the parking sensors.

COLD WEATHER DRIVING

FREEING A FROZEN DOOR LOCK

To prevent a door lock from freezing, apply deicer through the key hole. If the lock becomes frozen, heat the key before inserting it into the key hole, or use the F.A.S.T.-key.

ANTI-FREEZE

In the winter when it is anticipated that the outside temperature will drop below 32°F (0°C), check the anti-freeze to assure proper winter protection. For additional information, see “Engine cooling system” (P.8-4).

BATTERY

If the battery is not fully charged during extremely cold weather conditions, the battery fluid may freeze and damage the battery. To maintain maximum efficiency, the battery should be checked regularly. For additional information, see “Battery” (P.8-11).

DRAINING OF COOLANT WATER

If the vehicle is to be left outside without anti-freeze, drain the cooling system, including the engine block. Refill before operating the vehicle. For details, see “Engine cooling system” (P.8-4).

TIRE EQUIPMENT

SUMMER tires have a tread designed to provide superior performance on dry pavement. However, the performance of these tires will be substantially reduced in snowy and icy conditions. If you operate your vehicle on snowy or icy roads, Mitsubishi Motors recommends the use of MUD & SNOW or ALL SEASON tires on all four wheels. It is recommended you consult an authorized Mitsubishi Motors dealer for the tire type, size, speed rating and availability information.

For additional traction on icy roads, studded tires may be used. However, some U.S. states and Canadian provinces prohibit their use. Check local, state and provincial laws before installing studded tires.

Skid and traction capabilities of studded snow tires, on wet or dry surfaces, may be poorer than that of non-studded snow tires.

Tire chains may be used. For details, see “Tire chains” (P.8-33) of this manual.

All-Wheel Control (AWC) model

If you install snow tires, they must also be the same size, brand, construction and tread pattern on all four wheels.

SPECIAL WINTER EQUIPMENT

It is recommended that the following items be carried in the vehicle during winter:

- A scraper and stiff-bristled brush to remove ice and snow from the windows and wiper blades.
- A shovel to dig the vehicle out of snow-drifts.
- Extra window washer fluid to refill the reservoir tank.

DRIVING ON SNOW OR ICE

WARNING

- Wet ice (32°F, 0°C and freezing rain), very cold snow or ice can be slick and very hard to drive on. The vehicle will have much less traction or “grip” under these conditions. Try to avoid driving on wet ice until the road is salted or sanded.
- Whatever the condition, drive with caution. Accelerate and slow down with care. If accelerating or downshifting too fast, the drive wheels will lose even more traction.
- Allow more stopping distance under these conditions. Braking should be started sooner than on dry pavement.

- Allow greater following distances on slippery roads.
- Watch for slippery spots (glare ice). These may appear on an otherwise clear road in shaded areas. If a patch of ice is seen ahead, brake before reaching it. Try not to brake while on the ice, and avoid any sudden steering maneuvers.
- Do not use cruise control on slippery roads.
- Snow can trap dangerous exhaust gases under your vehicle. Keep snow clear of the exhaust pipe and from around your vehicle.

6 *In case of emergency*

Hazard warning flasher switch	6-2	Push starting	6-14
Emergency engine shut off	6-2	If your vehicle overheats	6-14
Flat tire	6-3	Towing your vehicle	6-16
Tire Pressure Monitoring System (TPMS)	6-3	Towing recommended by Mitsubishi Motors	6-17
Tire repair kit	6-3	Vehicle recovery (freeing a stuck vehicle)	6-19
Jump starting	6-12		

HAZARD WARNING FLASHER SWITCH

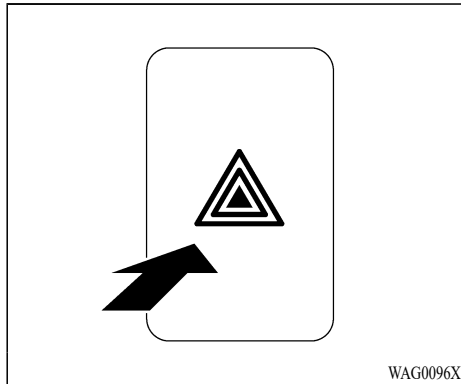

Push the switch on to warn other drivers when you must stop or park under emergency conditions. All turn signal lights will flash.

WARNING

- If stopping for an emergency, be sure to move the vehicle well off the road.
- Do not use the hazard warning flashers while moving on the highway unless unusual circumstances force you to drive so slowly that your vehicle might become a hazard to other traffic.
- Turn signals do not work when the hazard warning flasher lights are on.

6-2 In case of emergency

Condition:

The flasher can be actuated with the ignition switch in any position.

WARNING

Do not turn the hazard warning flasher switch to off until you can make sure that it is safe to do so. Also, the hazard flasher warning may not blink automatically depending on the force of impact.

Some state laws may prohibit the use of the hazard warning flasher switch while driving.

EMERGENCY ENGINE SHUT OFF

To shut off the engine in an emergency situation while driving, perform the following procedure:

- Rapidly push the push-button ignition switch 3 consecutive times in less than 1.5 seconds, or
- Push and hold the push-button ignition switch for more than 2 seconds.

FLAT TIRE

TIRE PRESSURE MONITORING SYSTEM (TPMS)

This vehicle is equipped with the Tire Pressure Monitoring System (TPMS). It monitors tire pressure of all tires. When the low tire pressure warning light is lit, and the “Tire Pressure Low - Add Air”/“Tire Pressure Low - Check Cold Tire” warning message is displayed in the multi-information display, one or more of your tires is significantly under-inflated. If the vehicle is being driven with low tire pressure, the TPMS will activate and warn you of it by the low tire pressure warning light. This system will activate only when the vehicle is driven at speeds above 16 MPH (25 km/h). For more details, see “Warning lights, indicator lights and audible reminders” (P.2-12) and “Tire Pressure Monitoring System (TPMS)” (P.5-6).

WARNING

- If the low tire pressure warning light illuminates while driving, avoid sudden steering maneuvers or abrupt braking, reduce vehicle speed, pull off the road to a safe location and stop the vehicle as soon as possible. Driving with under-inflated tires may permanently damage the tires and increase the likelihood of tire failure. Serious vehicle damage could occur and may lead to an accident and could result in

serious personal injury. Check the tire pressure for all four tires. Adjust the tire pressure to the recommended COLD tire pressure shown on the Tire and Loading Information placard to turn the low tire pressure warning light OFF. If the light still comes on while driving after adjusting the tire pressure, a tire may be flat or the TPMS may be malfunctioning. If you have a flat tire, repair it with a tire repair kit. If no tire is flat and all tires are properly inflated, it is recommended you consult an authorized Mitsubishi Motors dealer.

- If a wheel that not equipped with the TPMS is installed, the TPMS will not function and the low tire pressure warning light will flash for approximately 1 minute. The light will remain on after 1 minute. Have your tires replaced and/or TPMS system reset as soon as possible. It is recommended you visit an authorized Mitsubishi Motors dealer for these services.
- Do not inject any tire liquid or aerosol tire sealant (except the sealant of the genuine tire repair kit) into the tires, as this may cause a malfunction of the tire pressure sensors.

TIRE REPAIR KIT

The tire repair kit can be used to temporarily repair a minor puncture in tread area caused by a nail, screw or similar object. Therefore, a spare tire is not provided.

WARNING

- The tire repair kit may not permanently seal a punctured tire. Have the tire repaired as soon as possible.
- Using the tire repair kit may damage the wheel and/or the tire inflation pressure sensor for the tire. The vehicle must promptly be inspected and repaired by an authorized Mitsubishi Motors dealer after using the tire repair kit.
- Use only the Mitsubishi Motors genuine tire repair kit. Sealant in other repair kits may not sufficiently seal the tire puncture.

In case of emergency 6-3

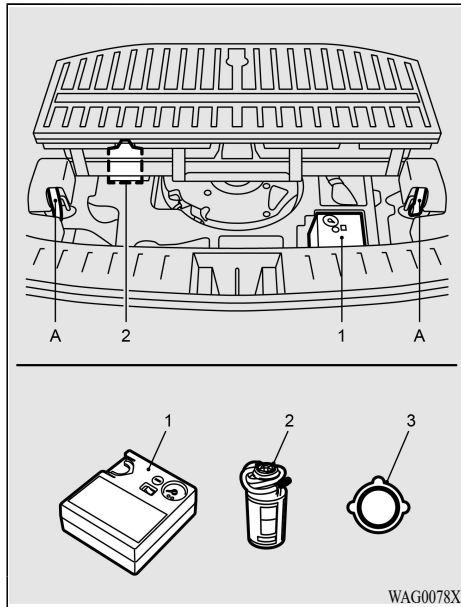

Example

Tire repair kit storage

The design and the storage position of the tire repair kit may vary depending on the vehicle.

Tire repair kit which consists of 1 to 3.

1. Tire compressor
2. Tire sealant bottle

6-4 In case of emergency

3. Speed restriction sticker

A. Strap (for flipping up the third row seats)

Before taking out the tire repair kit, fold the third row seats (see “Third row seats” (P.1-9)) and then flip up the third row seats by pulling the strap A.

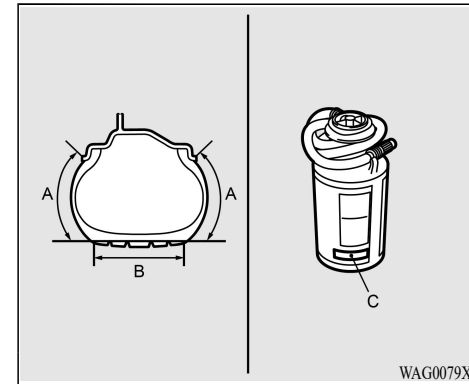

Example

How to use the tire repair kit

! WARNING

Never use the tire repair kit under in any of the situations listed below. The tire cannot be repaired by the tire repair kit. If any of these situations occurs, please contact an authorized Mitsubishi Motors dealer.

- More than one tire is punctured.
- The puncture hole has a length or width of 1/7 inch (4 mm) or greater.
- The tire is punctured in the side wall (A), not in the tread (B).

- The vehicle has been driven with the tire almost completely flat.
- The tire has completely slipped over the wheel rim and come off the wheel.
- The wheel is damaged.
- A bump, cut or crack is on the tire.
- The tire sealant's expiration date has passed. (The expiration date is shown on the bottle label (C).)
- The ambient temperature is below -40 °F (-40 °C) or above 140 °F (60 °C).
- The tire sealant can cause health damage if swallowed. If you accidentally swallow it, drink as much water as possible and immediately seek medical attention.
- If the tire sealant gets in your eyes or on your skin, rinse it away with lots of water. If you still sense an abnormality, seek medical attention.
- Consult a doctor immediately if any allergic reactions occur.
- Do not allow children to touch the tire sealant.

CAUTION

- If the vehicle body is contaminated by the tire sealant, wipe the tire sealant off

immediately with a wet cloth.

- Immediately wash clothes contaminated with tire sealant. The tire sealant may not be removed from the clothes.

NOTE:

- Do not pull out an object, such as a nail or screw, that penetrates the punctured tire.
 - Move the vehicle so that the tire valve is positioned away from the point where the tire touches the ground. If the valve is near the point where the tire touches the ground, the sealant may not enter the tire easily.
 - Check the tire sealant's expiration date regularly, and be sure to purchase a new one from an authorized Mitsubishi Motors dealer before the expiration date.
1. Park the vehicle on a safe, flat and level place.
 2. Set the parking brake firmly.
 3. Move the selector lever to the "P" (PARK) position, and stop the engine.
 4. Turn on the hazard warning lights and set up a warning sign, such as a warning triangle or flashing signal lamp, at an adequate distance from the vehicle, and have all your passengers leave the vehicle.

5. Flip up the third row seats (see "Tire repair kit storage" (P.6-4)). Then, take out the tire repair kit. Make sure that the compressor switch is OFF.
6. Shake the tire sealant bottle well.

In case of emergency 6-5

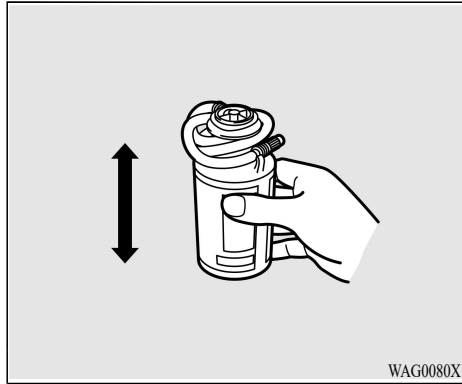

Example

NOTE:

In cold conditions (when the ambient temperature is 32 °F (0 °C) or lower), thickening of the tire sealant can make the tire sealant hard to squeeze out of the bottle. Warm the bottle between your hands inside the vehicle.

7. Take the valve cap (D) off the tire valve (E).

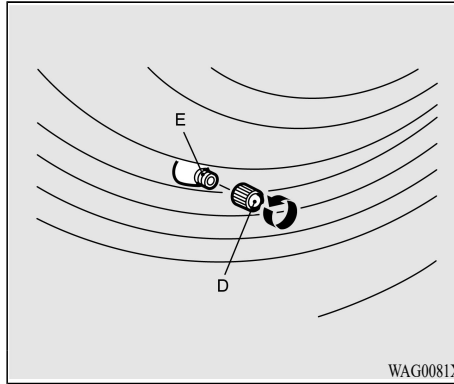

8. Unwind the bottle hose (F) from around the sealant bottle.

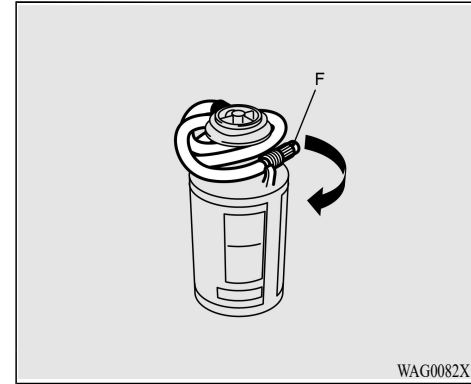

Type A

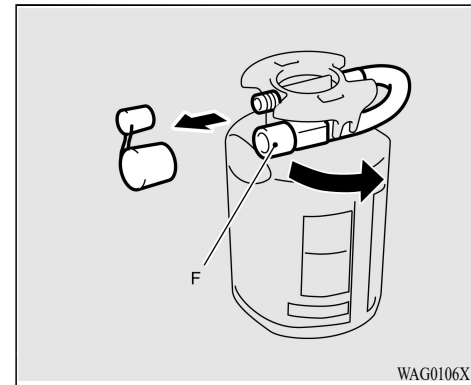

Type B

6-6 In case of emergency

9. Pull out the compressor's hose (G) from the bottom of the compressor and securely attach it to the valve (H) of the bottle by turning it clockwise until tight.

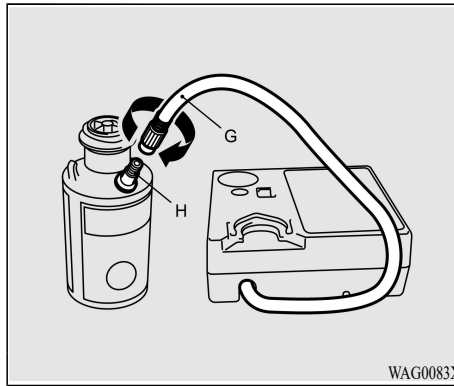

Type A

10. Install the bottle onto the compressor.

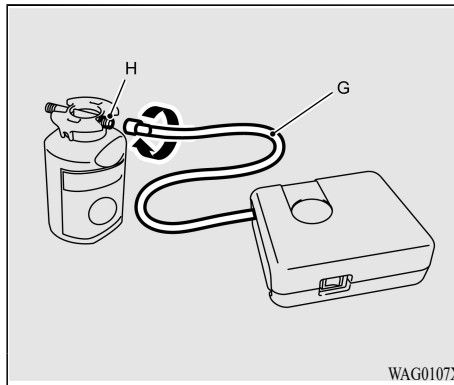

Type B

In case of emergency 6-7

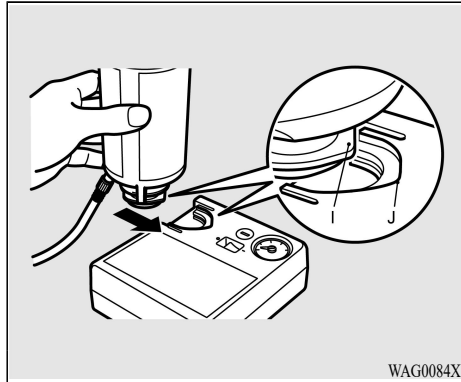

WAG0084X

NOTE:

When installing the bottle, align the projection (I) on the bottle with the indentation (J) in the compressor.

11. Securely attach the bottle hose (F) to the tire valve (E).

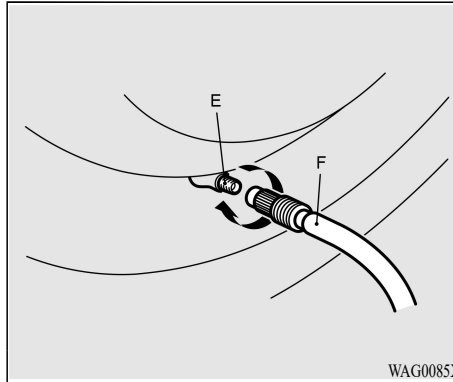

WAG0085X

CAUTION

If the bottle hose is not attached securely, the tire sealant will leak out from the tire valve and the tire may not inflate to the specified pressure.

12. Pull out the compressor's power cord (K), insert the plug on the cord into the 12 V power outlet (L), and then turn the ignition switch or the operation mode to the ACC position. (See "Power outlet" (P.2-63).) Turn ON the compressor switch (M) and inject all of the tire sealant and inflate the tire to the specified pressure. (See "Wheels

and tires" (P.10-8).) If there is a gap between the tire and wheel, push the tread area toward the center of the wheel to close the gap before running the compressor.

6-8 In case of emergency

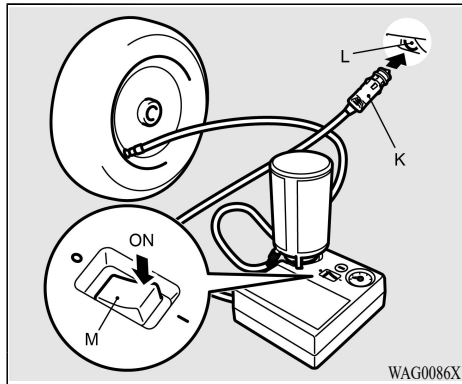

Type A

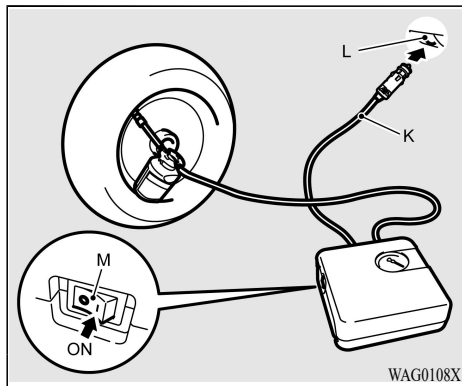

Type B

! WARNING

Do not place your hand or fingers between the tire and wheel while inflating the tire. Your hand or fingers may become caught between the tire and wheel.

! CAUTION

- The supplied compressor is designed only for inflation of your vehicle tires.
- The compressor is designed to run on a vehicle's 12 V power supply. Do not connect it to any other power source.
- The compressor is not waterproof. If you use it in rain, make sure water does not get on it.
- Any sand or dust sucked into the compressor could make the compressor break down. Do not place the compressor directly on any sandy or dusty surface when using it.
- Do not disassemble or modify the compressor. Also, do not subject the air pressure gauge to shock. It could malfunction.

13. Affix the speed restriction sticker (N) to the three-diamond mark on the steering wheel.

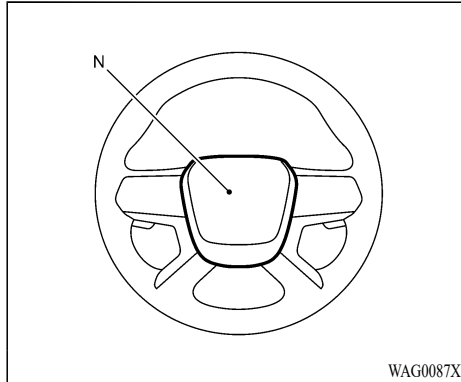

CAUTION

Do not affix the sticker anywhere except the specified position on the pad of the steering wheel. Affixing the sticker in an incorrect position could prevent the SRS airbag from deploying properly.

14. Check and adjust the tire pressure with reference to the air pressure gauge on the compressor. If you overinflate the tire, release air by pressing the pressure release switch (O) on the compressor.

6-10 In case of emergency

Condition:

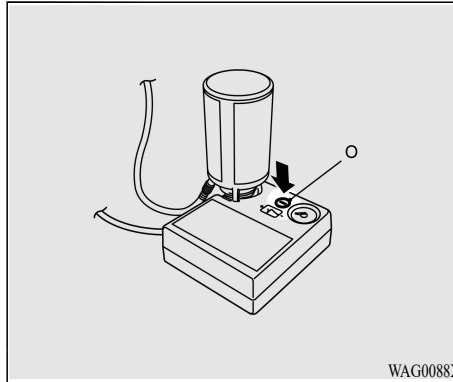

CAUTION

- The surface of the compressor will get hot while the compressor is running. Do not keep the compressor running continuously for more than 10 minutes. After using the compressor, wait for the compressor to cool before using it again.
- If the compressor becomes sluggish or hot while operating, it is overheating. Immediately place the switch in the OFF position and let the compressor cool down for at least 30 minutes.
- Do not press the pressure release switch (O) while sealant is being injected, because

the sealant may leak from compressor.

NOTE:

If the tire pressure does not rise to the specified level within 10 minutes, the tire may be so severely damaged that the tire sealant cannot be used for emergency repair. Do not drive the vehicle. Please contact an authorized Mitsubishi Motors dealer.

15. Turn OFF the compressor switch, then pull the power cord plug out of the 12 V power outlet.

NOTE:

At this point the puncture hole is not sealed yet. Air will continue to leak through the puncture hole until the emergency repair procedure is completed (through step 17 or step 18 of these instructions).

16. When you have inflated the tire to the specified pressure, stow the compressor and bottle in the vehicle and promptly start driving the vehicle so that the tire sealant can spread evenly in the tire. Drive with great care. Do not exceed a speed of 50 MPH (80 km/h). Observe local speed limits.

CAUTION

If you sense any abnormality while driving, stop the vehicle and contact an authorized Mitsubishi Motors dealer. Otherwise the tire pressure may drop before the emergency repair procedure is completed, rendering the vehicle unsafe to drive.

17. After driving for 10 minutes or 3 miles (5 km), park the vehicle in a safe place. Remove the air compressor from the stowed position. Check the tire pressure using the air pressure gauge on the compressor. If the tire pressure has not dropped, the emergency repair procedure is complete. Proceed to step 19. If the tire pressure is insufficient, inflate the tire to the specified pressure again and drive the vehicle carefully without exceeding a speed of 50 MPH (80 km/h). Before driving, make sure that the compressor is stowed.

CAUTION

If the tire pressure is lower than the minimum permitted pressure (18 psi {130 kPa}), the tire cannot successfully be repaired with the tire sealant. Do not drive the vehicle any further. Contact an authorized Mitsubishi Motors dealer.

er.

18. After driving for 10 minutes or 3 miles (5 km) again, check the tire pressure using the air pressure gauge on the compressor. If the tire pressure has not dropped, the emergency repair procedure is complete. Before driving, make sure that the compressor is stowed. You must still not exceed a speed of 50 MPH (80 km/h). Observe local speed limits.

NOTE:

- If the tire pressure has dropped below the specified level when you check it at the end of the repair procedure, do not drive the vehicle any further. Contact an authorized Mitsubishi Motors dealer.
- In cold conditions (when the ambient temperature is 32 °F (0 °C) or lower), the time and driving distance required until completion of the repair can become longer than in warmer conditions, and the tire pressure may drop below the specified level even after you have inflated the tire the second time and subsequently driven the vehicle. If this happens, inflate the tire to the specified pressure once more, drive for approximately 10 minutes or 3 miles (5 km), then check the tire pressure again. If the tire pressure has again dropped below the

specified level, stop driving the vehicle and contact an authorized Mitsubishi Motors dealer.

19. Immediately drive with great care to an authorized Mitsubishi Motors dealer and have the tire repair/replacement performed.

NOTE:

- Please give the empty sealant bottle to an authorized Mitsubishi Motors dealer or dispose of the sealant bottle according to regulations for the disposal of chemical waste.
- To purchase a new tire sealant bottle, contact an authorized Mitsubishi Motors dealer.

In case of emergency 6-11

JUMP STARTING

To start your engine with a booster battery, the instructions and precautions below must be followed.

WARNING

- If done incorrectly, jump starting can lead to a battery explosion, resulting in severe injury or death. It could also damage your vehicle.
- Explosive hydrogen gas is always present in the vicinity of the battery. Keep all sparks and flames away from the battery.
- Do not allow battery fluid to come into contact with eyes, skin, clothing or painted surfaces. Battery fluid is a corrosive sulfuric acid solution which can cause severe burns. If the fluid should come into contact with anything, immediately flush the contacted area with water.
- Keep the battery out of the reach of children.
- The booster battery must be rated at 12 volts. Use of an improperly rated battery can damage your vehicle.
- Whenever working on or near a battery, always wear suitable eye protectors (for example, goggles or industrial safety spectacles) and remove rings, metal bands, or any other jewelry. Do not lean over the battery when jump starting.

- Do not attempt to jump start a frozen battery. It could explode and cause serious injury.
- Your vehicle has an automatic engine cooling fan. It could come on at any time. Keep hands and other objects away from it.

6-12 In case of emergency

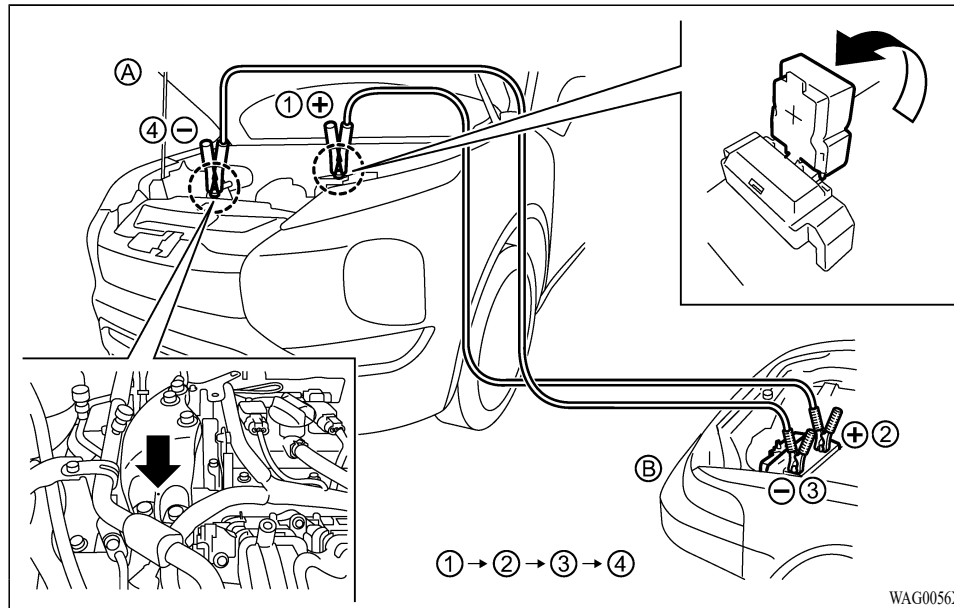

! WARNING

Always follow the instructions below. Failure to do so could result in damage to the charging system and cause personal injury.

1. If the booster battery is in another vehicle ②, position the two vehicles (① and ②) to bring their batteries into close proximity to each other.
Do not allow the two vehicles to touch.
2. Apply the parking brake.

3. Push the park button to shift to the P (Park) position.
4. Switch off all unnecessary electrical systems (headlights, heater, air conditioner, etc.).
5. Remove the vent caps on the battery (if so equipped). Cover the battery with a firmly wrung out moist cloth to reduce explosion hazard.
6. Connect jumper cables in the sequence as illustrated (① → ② → ③ → ④).

! CAUTION

- Always connect positive (+) to positive (+) and negative (-) to body ground (for example, as illustrated), not to the battery.
- Make sure the jumper cables do not touch moving parts in the engine compartment and that the cable clamps do not contact any other metal.

7. Start the engine of the booster vehicle ② and let it run for a few minutes.
8. Keep the engine speed of the booster vehicle ② at about 2,000 rpm, and start the engine of the vehicle ① being jump started.

In case of emergency 6-13

CAUTION

Do not keep the starter motor engaged for more than 10 seconds. If the engine does not start right away, place the ignition switch in the OFF position and wait 10 seconds before trying again.

9. After starting your engine, carefully disconnect the negative cable and then the positive cable (④ → ③ → ② → ①).
10. Replace the vent caps (if so equipped). Be sure to dispose of the cloth used to cover the vent holes as it may be contaminated with corrosive acid.

PUSH STARTING

Do not attempt to start the engine by pushing.

CAUTION

- Continuously Variable Transmission (CVT) models cannot be push-started or tow-started. Attempting to do so may cause transmission damage.
- Three-way catalyst equipped models should not be started by pushing since the three way catalyst may be damaged.
- Never try to start the vehicle by towing it; when the engine starts, the forward surge could cause the vehicle to collide with the tow vehicle.

IF YOUR VEHICLE OVERHEATS

WARNING

- Never continue driving if your vehicle overheats. Doing so could cause a vehicle fire.
- Never open the hood if steam is coming out.
- Never remove the radiator or coolant reservoir cap while the engine is hot. If the radiator or coolant reservoir cap is removed when the engine is hot, pressurized hot water will spurt out and possibly cause burning, scalding or serious injury.
- If steam or coolant is coming from the engine, stand clear of the vehicle to prevent getting burned.
- The engine cooling fan will start at any-time when the coolant temperature exceeds preset degrees.
- Be careful not to allow your hands, hair, jewelry or clothing to come into contact with, or to get caught in the cooling fan or drive belts.



Warning labels (example)

If your vehicle is overheating (indicated by an extremely high temperature gauge reading), or if you feel a lack of engine power, detect abnormal noise, etc., take the following steps:

1. Move the vehicle safely off the road and apply the parking brake.
2. Push the park button to shift to the P (Park) position.

Do not stop the engine.

3. Turn off the air conditioner. Open all the windows, move the heater or air conditioner temperature control to maximum hot and fan control to high speed.

4. Get out of the vehicle. Look and listen for steam or coolant escaping from the radiator before opening the hood. (If steam or coolant is escaping, turn off the engine.) Do not open the hood further until no steam or coolant can be seen.
5. Open the engine hood.

WARNING

If steam or water is coming from the engine, stand clear to prevent getting burned.

6. Visually check the drive belt for damage or looseness. Also check if the cooling fan is running. The radiator hoses and radiator should not leak water. If coolant is leaking or the cooling fan does not run, stop the engine.

WARNING

Be careful not to allow your hands, hair, jewelry or clothing to come into contact with, or get caught in, engine belts or the engine cooling fan. The engine cooling fan can start at any time.

In case of emergency 6-15

TOWING YOUR VEHICLE

When towing your vehicle, all jurisdictional and local regulations for towing must be followed. Incorrect towing equipment could damage your vehicle. Towing instructions are available from an authorized Mitsubishi Motors dealer. Local service operators are generally familiar with the applicable laws and procedures for towing. To assure proper towing and to prevent accidental damage to your vehicle, Mitsubishi Motors recommends that you have a service operator tow your vehicle. It is advisable to have the service operator carefully read the following precautions.

WARNING

- Never ride in a vehicle that is being towed.
- Never get under your vehicle after it has been lifted by a tow truck.

CAUTION

- When towing, make sure that the transmission, axles, steering system and power-train are in working condition. If any of these conditions apply, dollies or a flatbed tow truck must be used.

- Always attach safety chains before towing.

For information about towing your vehicle behind a recreational vehicle (RV), see “Flat towing” (P.10-29) of this manual.

6-16 In case of emergency

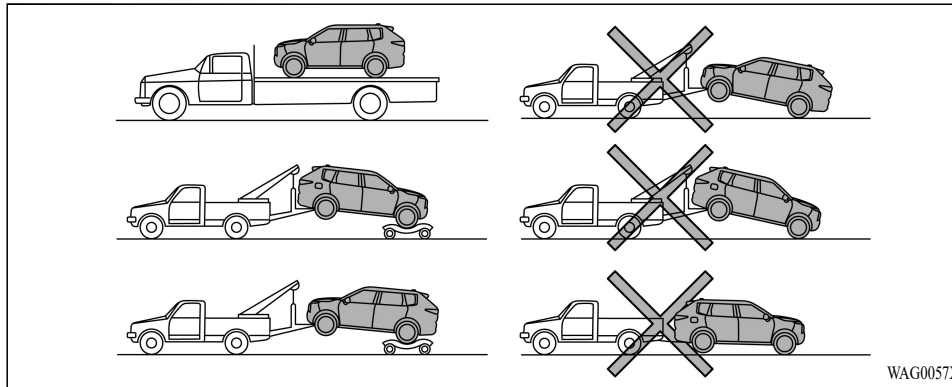

All-Wheel Control models

TOWING RECOMMENDED BY MITSUBISHI MOTORS

All-Wheel Control (AWC) models

Mitsubishi Motors recommends that towing dollies be used when towing your vehicle or the vehicle be placed on a flat bed truck as illustrated.

CAUTION

Never tow AWC models with any of the wheels on the ground as this may cause serious and expensive damage to the powertrain.

In case of emergency 6-17

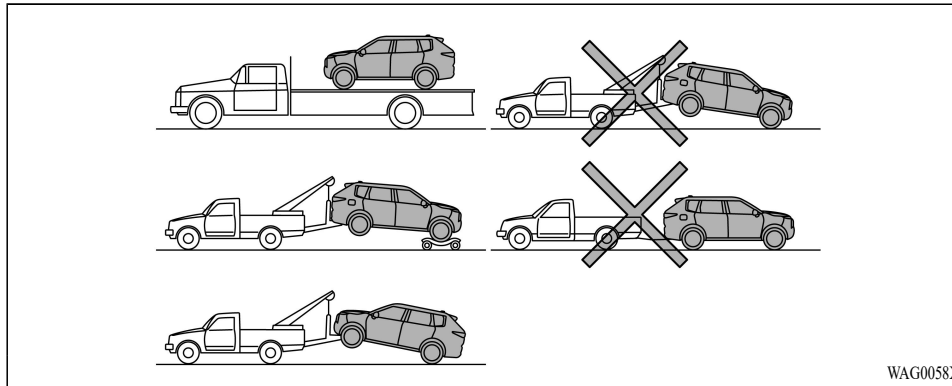

WAG0058X

Front-wheel drive models

Front-Wheel Drive (FWD) models

Mitsubishi Motors recommends that your vehicle be towed with the driving (front) wheels off the ground or place the vehicle on a flat bed truck as illustrated.

CAUTION

- Never tow CVT models with the front wheels on the ground or four wheels on the ground (forward or backward), as this may cause serious and expensive damage to the transmission. If it is necessary to tow the vehicle with the rear wheels raised, always use towing dollies under the front

wheels.

- When towing CVT models with the front wheels on towing dollies: Place the ignition switch in the OFF position, and secure the steering wheel in a straight-ahead position with a rope or similar device. Move the shift lever to the N (Neutral) position.
- When towing a CVT model with the rear wheels on the ground (if you do not use towing dollies): Always release the parking brake.

Front wheels on the ground:

Mitsubishi Motors recommends that towing dollies be used under the front wheels when

towing your vehicle or the vehicle be placed on a flatbed tow truck as illustrated.

CAUTION

Never tow Continuously Variable Transmission (CVT) model with the front wheels on the ground. Doing so will cause serious and expensive damage to the drivetrain.

Rear wheels on the ground:

1. Place the ignition switch in the OFF position.
2. Move the shift lever to the N (Neutral) position.
3. Release the parking brake.
4. Attach safety chains whenever towing.

All four wheels on the ground:

Mitsubishi Motors recommends that the vehicle be placed on a flatbed tow truck as illustrated.

CAUTION

Never tow CVT model with all four wheels on the ground. Doing so will cause serious and expensive damage to the drivetrain.

VEHICLE RECOVERY (freeing a stuck vehicle)

WARNING

To avoid vehicle damage, serious personal injury or death when recovering a stuck vehicle:

- Contact a professional towing service to recover the vehicle if you have any questions regarding the recovery procedure.
- Tow chains or cables must be attached only to main structural members of the vehicle.
- Do not use the vehicle tie-downs to tow or free a stuck vehicle.
- Only use devices specifically designed for vehicle recovery and follow the manufacturer's instructions.
- Always pull the recovery device straight out from the front of the vehicle. Never pull at an angle.
- Route recovery devices so they do not touch any part of the vehicle except the attachment point.

If your vehicle is stuck in sand, snow, mud, etc., use a tow strap or other device designed specifically for vehicle recovery. Always follow the manufacturer's instructions for the recovery

device.

Rocking a stuck vehicle

WARNING

- Stand clear of a stuck vehicle.
- Do not spin your tires at high speed. This could cause them to explode and result in serious injury. Parts of your vehicle could also overheat and be damaged.

If your vehicle is stuck in sand, snow, mud, etc., use the following procedure:

1. Turn off the Active stability control (ASC).
2. Make sure the area in front and behind the vehicle is clear of obstructions.
3. Turn the steering wheel right and left to clear an area around the front tires.
4. Slowly rock the vehicle forward and backward.
 - Shift back and forth between R (Reverse) and D (Drive).
 - Apply the accelerator as little as possible to maintain the rocking motion.
 - Release the accelerator pedal before shifting between R and D.
 - Do not spin the tires above 35 MPH (55 km/h).

5. If the vehicle cannot be freed after a few tries, contact a professional towing service to remove the vehicle.

WARNING

- Stand clear of a stuck vehicle.
- Do not spin your tires at high speed. This could cause them to explode and result in serious injury. Parts of your vehicle could also overheat and be damaged.

In case of emergency 6-19

MEMO

6-20 **In case of emergency**

Condition:

7 *Appearance and care*

Cleaning exterior	7-2	Floor mats	7-4
Washing	7-2	Seat belts	7-6
Waxing	7-2	Cleaning the seat tracks	7-6
Removing spots	7-2	Corrosion protection	7-6
Underbody	7-3	Most common factors contributing to	
Glass	7-3	vehicle corrosion	7-6
Chrome parts	7-3	Environmental factors influence the rate	
Aluminum wheels	7-3	of corrosion	7-6
Cleaning interior	7-4	To protect your vehicle from corrosion	7-7
Air fresheners	7-4		

CLEANING EXTERIOR

In order to maintain the appearance of your vehicle, it is important to take proper care of it.

To protect the paint surfaces, wash your vehicle as soon as you can:

- after a rainfall to prevent possible damage from acid rain
 - after driving on coastal roads
 - when contaminants such as soot, bird droppings, tree sap, metal particles or bugs get on the paint surface
 - when dust or mud builds up on the surface
- Whenever possible, store or park your vehicle inside a garage or in a covered area.

When it is necessary to park outside, park in a shady area or protect the vehicle with a body cover.

Be careful not to scratch the paint surface when putting on or removing the body cover.

WASHING

Wash dirt off the vehicle with a wet sponge and plenty of water. Clean the vehicle thoroughly using a mild soap, a special vehicle soap or general purpose dishwashing liquid mixed with clean, lukewarm (never hot) water.



CAUTION

- **Do not use car washes that use acid in the detergent. Some car washes, especially brushless ones, use some acid for cleaning. The acid may react with some plastic vehicle components, causing them to crack. This could affect their appearance, and also could cause them not to function properly. Always check with your car wash to confirm that acid is not used.**
- **Do not wash the vehicle with strong household soap, strong chemical detergents, gasoline or solvents.**
- **Do not wash the vehicle in direct sunlight or while the vehicle body is hot, as the surface may become water-spotted.**
- **Avoid using tight-napped or rough cloths, such as washing mitts. Care must be taken when removing caked-on dirt or other foreign substances so the paint surface is not scratched or damaged.**

Rinse the vehicle thoroughly with plenty of clean water.

Inside flanges, seams and folds on the doors, hatches and hood are particularly vulnerable to the effects of road salt. Therefore, these areas must be regularly cleaned. Make sure that the drain holes in the lower edge of the door are open. Spray water under the body and in the

wheel wells to loosen the dirt and wash away road salt.

Avoid leaving water spots on the paint surface by using a damp chamois to dry the vehicle.

WAXING

Regular waxing protects the paint surface and helps retain new vehicle appearance. Polishing is recommended to remove built-up wax residue and to avoid a weathered appearance before reapplying wax.

- Wax your vehicle only after a thorough washing. Follow the instructions supplied with the wax.
- Do not use a wax containing any abrasives, cutting compounds or cleaners that may damage the vehicle finish.

Machine compound or aggressive polishing on a base coat/clear coat paint finish may dull the finish or leave swirl marks.

REMOVING SPOTS

Remove tar and oil spots, industrial dust, insects, and tree sap as quickly as possible from the paint surface to avoid lasting damage or staining. Special cleaning products are available at an authorized Mitsubishi Motors dealer or any automotive accessory stores. It is recommended that you visit an authorized Mitsubishi Motors dealer for these products.

UNDERBODY

In areas where road salt is used in winter, the underbody must be cleaned regularly. This will prevent dirt and salt from building up and causing the acceleration of corrosion on the underbody and suspension. Before the winter period and again in the spring, the underseal must be checked and, if necessary, re-treated.

GLASS

Use glass cleaner to remove smoke and dust film from the glass surfaces. It is normal for glass to become coated with a film after the vehicle is parked in the hot sun. Glass cleaner and a soft cloth will easily remove this film.

CAUTION

When cleaning the inside of the windows, do not use sharp-edged tools, abrasive cleaners or chlorine-based disinfectant cleaners. They could damage the electrical conductors, radio antenna elements or electric rear window defroster elements.

CHROME PARTS

To prevent spots and corrosion of chrome parts, wash with water, dry thoroughly, and apply a nonabrasive automotive wax. If the chrome is severely damaged or pitted, use a commercially available chrome polish.

ALUMINUM WHEELS

1. Remove dirt using a wet sponge.
2. Use a mild detergent on any dirt that cannot be removed easily with water. Rinse off the detergent after washing the wheels.
3. Dry the wheels thoroughly using a chamois leather or a soft cloth.

CAUTION

Follow the directions below to avoid staining or discoloring the wheels:

- Do not use a brush or other hard implement on the wheels.
- Do not use any cleaner that contains an abrasive substance or is acidic or alkaline. Doing so could cause the coating on the wheels to peel or become discolored or stained.
- Do not directly apply hot water using a steam cleaner or by any other means.

- Contact with seawater or road salt used for de-icing can cause corrosion. Rinse off such substances as soon as possible.

CLEANING INTERIOR

Occasionally remove loose dust from the interior trim, plastic parts and seats using a vacuum cleaner or soft bristled brush. Wipe the vinyl and leather surfaces with a clean, soft cloth dampened in mild soap solution, then wipe clean with a dry soft cloth.

Regular care and cleaning is required in order to maintain the appearance of the leather.

Before using any fabric protector, read the manufacturer's recommendations. Some fabric protectors contain chemicals that may stain or bleach the seat material.

Use a cloth dampened only with water, to clean the meter and gauge lens.

WARNING

Do not use water or acidic cleaners (hot steam cleaners) on the seat. This can damage the seat or occupant classification sensors. This can also affect the operation of the airbag system and result in serious personal injury.

CAUTION

- Never use benzine, thinner, or any similar material.

- For cleaning, use a soft cloth, dampened with water. Never use a rough cloth, alcohol, benzine, thinner or any kind of solvent or paper towel with a chemical cleaning agent. They will scratch or cause discoloration to the lens.
- Do not spray any liquid such as water on the meter lens. Spraying liquid may cause the system to malfunction.
- Small dirt particles can be abrasive and damaging to the leather surfaces and should be removed promptly. Do not use saddle soap, car waxes, polishes, oils, cleaning fluids, solvents, detergents or ammonia-based cleaners as they may damage the leather's natural finish.
- Never use fabric protectors unless recommended by the manufacturer.
- Do not use glass or plastic cleaner on meter or gauge lens covers. It may damage the lens cover.

AIR FRESHENERS

Most air fresheners use a solvent that could affect the vehicle interior. If you use an air freshener, take the following precautions:

- Hanging-type air fresheners can cause permanent discoloration when they contact vehicle interior surfaces. Place the air freshener in a location that allows it to hang free and not contact an interior

surface.

- Liquid-type air fresheners typically clip on the vents. These products can cause immediate damage and discoloration when spilled on interior surfaces.

Carefully read and follow the manufacturer's instructions before using air fresheners.

FLOOR MATS

WARNING

To avoid potential pedal interference that may result in a collision, injury or death:

- NEVER place a floor mat on top of another floor mat in the driver front position or install them upside down or backwards.
- It is recommended that you use only genuine Mitsubishi Motors floor mats specifically designed for use in your vehicle model and model year.
- Properly position the mats on the floor using the floor mat positioning hooks. See "Floor mat installation" (P.7-5).
- Make sure the floor mat does not interfere with pedal operation.
- Periodically check the floor mats to make sure they are properly installed.

7-4 Appearance and care

- After cleaning the vehicle interior, check the floor mats to make sure they are properly installed.

The use of genuine Mitsubishi Motors floor mats can extend the life of your vehicle carpet and make it easier to clean the interior. Mats should be maintained with regular cleaning and replaced if they become excessively worn.

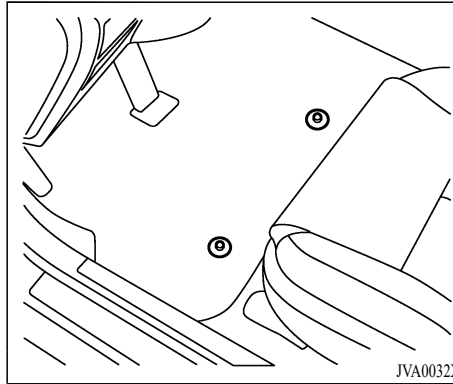

Example

Floor mat installation

Your vehicle is equipped with floor mat positioning hook(s). The number and shape of the floor mat positioning hook(s) for each seating position varies depending on the vehicle.

When installing genuine Mitsubishi Motors floor mats, follow the installation instructions provided with the floor mat and the following:

1. Position the floor mat in the floorwell so that the floor mat grommet holes are aligned with the hook(s).
2. Secure the grommet holes into the hook(s) and ensure that the floor mat is properly

positioned.

3. Make sure the floor mat does not interfere with pedal operation. With the ignition in the OFF position and the shift lever in the P (Park) position, fully apply and release all pedals. The floor mat must not interfere with pedal operation or prevent the pedal from returning to its normal position. It is recommended you see an authorized Mitsubishi Motors dealer for details about installing the floor mats in your vehicle.

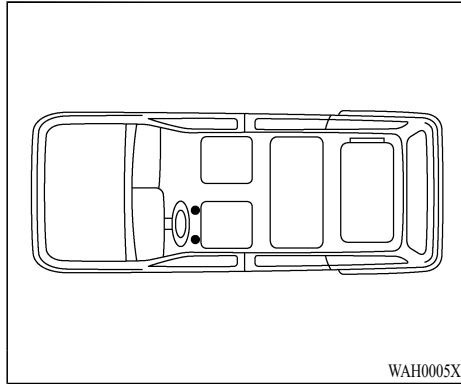

Positioning hook(s)

The illustration shows the location of the floor mat positioning hook(s).

SEAT BELTS

The seat belts can be cleaned by wiping them with a sponge dampened in a mild soap solution. Allow the belts to dry completely in the shade before using them.

See "Seat belts" (P.1-16).

WARNING

Do not allow wet seat belts to roll up in the retractor. NEVER use bleach, dye, or chemical solvents to clean the seat belts, since these

materials may severely weaken the seat belt webbing.

CLEANING THE SEAT TRACKS

CAUTION

Periodically clean the seat tracks to prevent reduction of ability to move the seats.

Clean periodically with a high-powered vacuum cleaner. Dirt and debris may reduce the ability to adjust the seat. A wet cleansing agent may be used if necessary.

CORROSION PROTECTION

MOST COMMON FACTORS CONTRIBUTING TO VEHICLE CORROSION

- The accumulation of moisture-retaining dirt and debris in body panel sections, cavities, and other areas.
- Damage to paint and other protective coatings caused by gravel and stone chips or minor traffic accidents.

ENVIRONMENTAL FACTORS INFLUENCE THE RATE OF CORROSION

Moisture

Accumulation of sand, dirt and water on the vehicle body underside can accelerate corrosion. Wet floor coverings will not dry completely inside the vehicle, and should be removed for drying to avoid floor panel corrosion.

Relative humidity

Corrosion will be accelerated in areas of high relative humidity, especially those areas where the temperatures stay above freezing where atmospheric pollution exists, or where road salt is used.

Temperature

A temperature increase will accelerate the rate of corrosion to those parts which are not well ventilated.

Air pollution

Industrial pollution, the presence of salt in the air in coastal areas, or heavy road salt use will accelerate the corrosion process. Road salt will also accelerate the disintegration of paint surfaces.

TO PROTECT YOUR VEHICLE FROM CORROSION

- Wash and wax your vehicle often to keep the vehicle clean.
- Always check for minor damage to the paint and repair it as soon as possible.
- Keep drain holes at the bottom of the doors open to avoid water accumulation.
- Check the underbody for accumulation of sand, dirt or salt. If present, wash with water as soon as possible.

CAUTION

- **NEVER** remove dirt, sand or other debris from the passenger compartment by washing it out with a hose. Remove dirt with a vacuum cleaner.

- **Never allow water or other liquids to come in contact with electronic components inside the vehicle as this may damage them.**

Chemicals used for road surface deicing are extremely corrosive. They accelerate corrosion and deterioration of underbody components such as the exhaust system, fuel and brake lines, brake cables, floor pan and fenders.

In winter, the underbody must be cleaned periodically.

For additional protection against rust and corrosion, which may be required in some areas, it is recommended you consult an authorized Mitsubishi Motors dealer.

(452,1)

MEMO

7-8 Appearance and care

Condition:

[Edit: 2021/ 2/ 10 Model: DG-D]

8 Do-it-yourself

Maintenance precautions	8-2	Rear window wiper blade	8-16
Engine compartment check locations	8-3	Brakes	8-16
PR25DD engine model	8-3	Self-adjusting brakes	8-16
Engine cooling system	8-4	Brake pad wear warning	8-16
Checking engine coolant level	8-5	Fuses	8-17
Changing engine coolant	8-5	Engine compartment	8-17
Engine oil	8-6	Passenger compartment	8-18
Checking engine oil level	8-6	F.A.S.T.-key battery replacement	8-20
Changing engine oil and filter	8-6	Lights	8-22
Continuously Variable Transmission (CVT) fluid	8-9	Headlights	8-22
Brake fluid	8-9	Exterior and interior lights	8-23
Window washer fluid	8-10	Tires	8-24
Battery	8-11	Tire Pressure Monitoring System (TPMS)	8-25
Disconnection and connection	8-12	Tire checking before driving	8-25
Jump starting	8-12	Tire Markings	8-26
Variable voltage control system	8-12	Tire inflation pressures	8-29
Drive belt	8-13	Replacing tires and wheels	8-30
Spark plugs	8-13	Tire maintenance	8-31
Replacing spark plugs	8-14	Tread wear indicator	8-31
Air cleaner	8-14	Tire rotation	8-31
Windshield wiper blades	8-15	Snow tires	8-33
Cleaning	8-15	Tire chains	8-33
Replacing	8-15		

MAINTENANCE PRECAUTIONS

When performing any inspection or maintenance work on your vehicle, always take care to prevent serious accidental injury to yourself or damage to the vehicle. The following are general precautions which should be closely observed.

WARNING

- Park the vehicle on a level surface, apply the parking brake securely and block the wheels to prevent the vehicle from moving. Push the park button to shift to the P (Park) position.
- Be sure the ignition switch is in the OFF or LOCK position when performing any parts replacement or repairs.
- If you must work with the engine running, keep your hands, clothing, hair and tools away from moving fans, belts and any other moving parts.
- It is advisable to secure or remove any loose clothing and remove any jewelry, such as rings, watches, etc. before working on your vehicle.
- Always wear eye protection whenever you work on your vehicle.
- If you must run the engine in an enclosed space such as a garage, be sure there is proper ventilation for exhaust gases to escape.

- Never get under the vehicle while it is supported only by a jack. If it is necessary to work under the vehicle, support it with safety stands.
- Because the fuel lines are under high pressure even when the engine is off, it is recommended you visit an authorized Mitsubishi Motors dealer for service of the fuel filter or fuel lines.
- Do not work under the hood while the engine is hot. Always turn off the engine and wait until it cools down.
- Keep smoking materials, flame and sparks away from fuel and the battery.
- On gasoline engine models with the Multiport Fuel Injection (MFI) system, the fuel filter and fuel lines should be serviced because the fuel lines are under high pressure even when the engine is turned off. It is recommended that you visit an authorized Mitsubishi Motors dealer for this service.
- Your vehicle is equipped with an automatic engine cooling fan. It may come on at any time without warning, even if the ignition switch is in the OFF position and the engine is not running. To avoid injury, always disconnect the negative battery cable before working near the fan.
- Avoid direct contact with used engine oil and coolant. Improperly disposed engine oil, engine coolant, and/or other vehicle

fluids can hurt the environment. Always conform to local regulations for disposal of vehicle fluids.

CAUTION

- Do not work under the hood while the engine is hot. Turn the engine off and wait until it cools down.
- Avoid direct contact with used engine oil and coolant. Improperly disposed engine oil, and engine coolant and/or other vehicle fluids can damage the environment. Always conform to local regulations for disposal of vehicle fluid.
- Never leave the engine or the CVT related component harnesses disconnected while the ignition switch is in the ON position.
- Never connect or disconnect the battery or any transistorized component while the ignition switch is in the ON position.
- Your vehicle is equipped with an automatic engine cooling fan. It may come on at any time without warning, even if the ignition key is in the OFF position and the engine is not running. To avoid injury, always disconnect the negative battery cable before working near the fan.

This “8. Do-it-yourself” section gives instruc-

8-2 Do-it-yourself

ENGINE COMPARTMENT CHECK LOCATIONS

tions regarding only those items which are relatively easy for an owner to perform.

You should be aware that incomplete or improper servicing may result in operating difficulties or excessive emissions, and could affect your warranty coverage. **If in doubt about any servicing, it is recommended you have it done by an authorized Mitsubishi Motors dealer.**

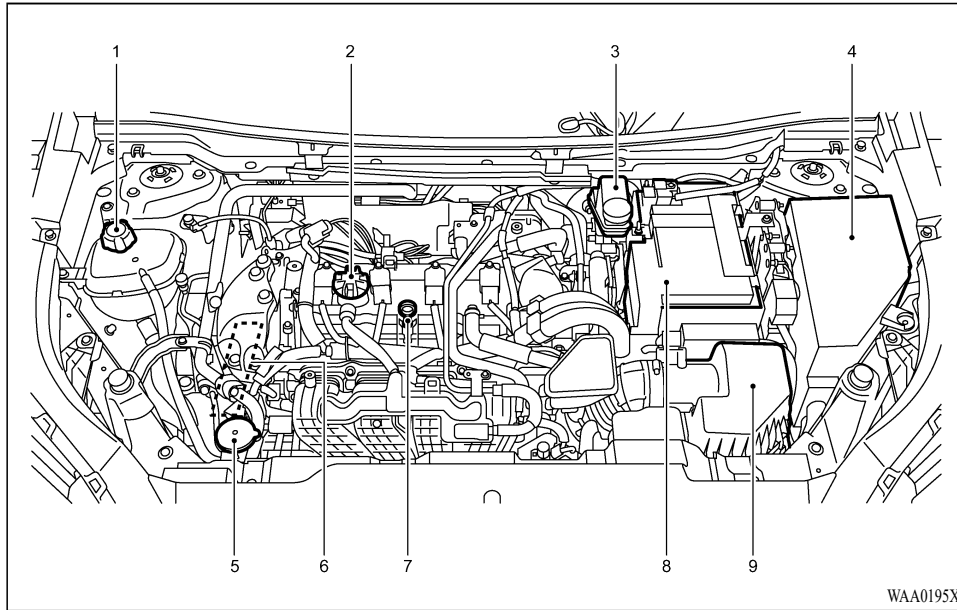

PR25DD ENGINE MODEL

- | | |
|----------------------------------|------------------------|
| 1. Engine coolant reservoir | 6. Drive belt |
| 2. Engine oil filler cap | 7. Engine oil dipstick |
| 3. Brake fluid reservoir | 8. Battery |
| 4. Fuse/fusible link box | 9. Air cleaner |
| 5. Window washer fluid reservoir | |

Do-it-yourself 8-3

ENGINE COOLING SYSTEM

The engine cooling system is filled at the factory with a pre-diluted mixture of 50% Mitsubishi Motors genuine Super Long Life Coolant Premium and 50% water to provide year-round anti-freeze and coolant protection. The anti-freeze solution contains rust and corrosion inhibitors. Additional engine cooling system additives are not necessary.

WARNING

- Never remove the radiator or coolant reservoir cap when the engine is hot. Wait until the engine and radiator cool down. Serious burns could be caused by high pressure fluid escaping from the radiator. See precautions in “If your vehicle overheats” (P.6-14) of this manual.
- The radiator is equipped with a pressure type radiator cap. To prevent engine damage, use only a genuine Mitsubishi Motors radiator cap.
- If the engine was stopped soon when the engine is hot, the cooling fan may operate for approximately 10 minutes after the engine was stopped to cool the components in the engine compartment. When the cooling fan is operating, be sure that hands or other items do not get caught in it.

CAUTION

- Never use any cooling system additives such as radiator sealer. Additives may clog the cooling system and cause damage to the engine, transmission and/or cooling system.
- When adding or replacing coolant, be sure to use only Mitsubishi Motors genuine Long Life Antifreeze/Coolant (blue) or equivalent. Mitsubishi Motors genuine Long Life Antifreeze/Coolant (blue) is pre-diluted to provide antifreeze protection to -31°F (-35°C). If additional freeze protection is needed due to weather where you operate your vehicle, add Mitsubishi Motors genuine Long Life Antifreeze/Coolant (blue) concentrate following the directions on the container. If an equivalent coolant other than Mitsubishi Motors genuine Long Life Antifreeze/Coolant (blue) is used, follow the coolant manufacturer's instructions to maintain minimum antifreeze protection to -31°F (-35°C). The use of other types of coolant solutions other than Mitsubishi Motors genuine Long Life Antifreeze/Coolant (blue) or equivalent may damage the engine cooling system.
- The life expectancy of the factory-fill coolant is 105,000 miles (168,000 km) or 7 years. Mixing any other type of coolant

other than Mitsubishi Motors genuine Long Life Antifreeze/Coolant (blue), including Mitsubishi Motors genuine Long Life Antifreeze/Coolant (green), or the use of non-distilled water will reduce the life expectancy of the factory-fill coolant.

8-4 Do-it-yourself

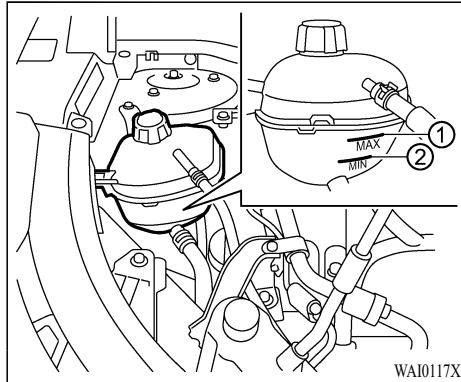

CHECKING ENGINE COOLANT LEVEL

Check the coolant level **in the reservoir when the engine is cold** after parking the vehicle on a level surface. If the coolant level is below the MIN level ②, open the reservoir cap and add coolant up to the MAX level ①. If the reservoir is empty, check the coolant level in the radiator **when the engine is cold**. If there is insufficient coolant in the radiator, fill the radiator with coolant up to the filler opening and also add it to the reservoir up to the MAX level ①.

Tighten the cap securely after adding engine coolant.

If the cooling system frequently requires

coolant, have it checked. It is recommended you visit an authorized Mitsubishi Motors dealer for this service.

WARNING

To avoid the blow out when the coolant is hot, never fill the coolant more than MAX level.

CHANGING ENGINE COOLANT

A authorized Mitsubishi Motors dealer can change the engine coolant.

Improper servicing can result in reduced heater performance and engine overheating.



Example

WARNING

- To avoid being scalded, never change the coolant when the engine is hot.
- Never remove the radiator or coolant reservoir cap when the engine is hot. Serious burns could be caused by high pressure fluid escaping from the radiator.
- Avoid direct skin contact with used coolant. If skin contact is made, wash thoroughly with soap or hand cleaner as soon as possible.
- Keep coolant out of the reach of children and pets.

ENGINE OIL

Engine coolant must be disposed of properly. Check your local regulations.

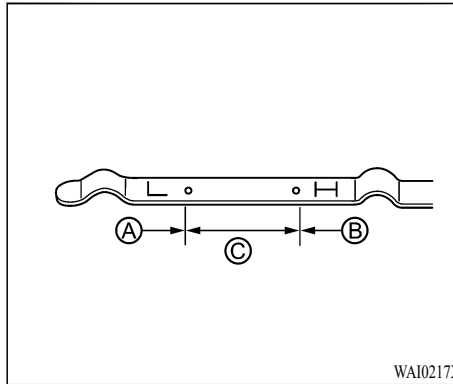

CHECKING ENGINE OIL LEVEL

1. Park the vehicle on a level surface and apply the parking brake.
2. Run the engine until it reaches operating temperature.
3. Turn off the engine. **Wait more than 10 minutes for the oil to drain back into the oil pan.**
4. Remove the dipstick and wipe it clean. Reinsert it all the way.
5. Remove the dipstick again and check the oil level. It should be within the range ©. If the oil level is below Ⓐ, remove the oil filler

cap and pour recommended oil through the opening. **Do not overfill** Ⓢ.

6. Recheck oil level with the dipstick.

It is normal to add some oil between oil maintenance intervals or during the break-in period, depending on the severity of operating conditions.

CAUTION

Oil level should be checked regularly. Operating the engine with an insufficient amount of oil can damage the engine, and such damage is not covered by the warranty.

CHANGING ENGINE OIL AND FILTER

WARNING

- Used oil must be disposed of properly. Never pour or dump oil into the ground, canals, rivers, etc. It should be disposed of at proper waste facilities. Mitsubishi Motors recommends having your oil changed by an authorized Mitsubishi Motors dealer.
- Be careful not to burn yourself, as the engine oil may be hot.

- Prolonged and repeated contact with used engine oil may cause skin cancer.
- Avoid direct skin contact with used oil. If contacted, wash thoroughly with soap or hand cleaner and plenty of water as soon as possible.
- Store used engine oil in marked containers out of the reach of children.

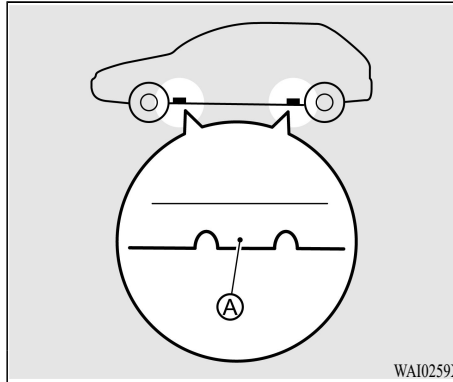

Vehicle set-up

1. Park the vehicle on a level surface and apply the parking brake.
2. Run the engine until it reaches the operating temperature.
3. Turn the engine off and wait more than 10 minutes.
4. Raise and support the vehicle using a suitable floor jack and safety jack stands.
 - Place the safety jack stands under the vehicle support points Ⓐ.
 - A suitable adapter should be attached to the jack stand saddle.

5. Remove the engine undercover.
 - Remove clips at the around of the undercover.
 - Then remove the other bolts that hold the undercover in place.



CAUTION

Make sure the correct lifting and support points are used to avoid vehicle damage.

Do-it-yourself 8-7

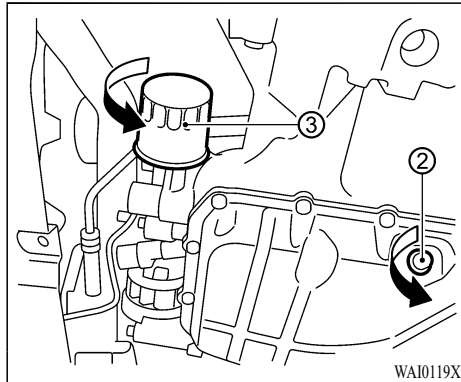
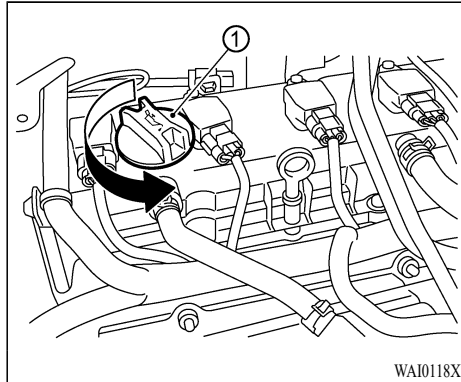

- ① Oil filler cap
- ② Oil drain plug
- ③ Oil filter

Engine oil and filter

1. Place a large drain pan under the drain plug ②.
2. Remove the oil filler cap ①.
3. Remove the drain plug ② with a wrench and completely drain the oil.

WARNING

- Prolonged and repeated contact with used engine oil may cause skin cancer.
- Try to avoid direct skin contact with used oil. If skin contact is made, wash thoroughly with soap or hand cleaner as soon as possible.
- Keep used engine oil out of reach of children.

CAUTION

Be careful not to burn yourself, as the engine oil is hot.

- Waste oil must be disposed of properly.
- Check your local regulations.

(Perform steps 4 to 7 only when the engine oil filter change is needed.)

4. Loosen the oil filter ③ with an oil filter wrench. Remove the oil filter by turning it by hand.
5. Wipe the engine oil filter mounting surface with a clean rag.

CAUTION

Be sure to remove any old gasket material remaining on the mounting surface of the engine. Failure to do so could lead to engine damage.

6. Coat the gasket on the new filter with clean engine oil.
7. Screw in the oil filter clockwise until a slight resistance is felt, then tighten additionally more than 2/3 turn.

Oil filter tightening torque:

11 to 15 ft-lb
(14.7 to 20.6 N·m)

8. Clean and re-install the drain plug with a new washer. Securely tighten the drain plug with a wrench.

CONTINUOUSLY VARIABLE TRANSMISSION (CVT) FLUID

When checking or replacement is required, we recommend an authorized Mitsubishi Motors dealer for servicing.

CAUTION

- Use only “Mitsubishi Motors Genuine CVTF-J4” transmission fluid to ensure optimum transmission performance.
- Do not use Automatic transmission fluid (ATF) or Manual Transmission fluid in a Mitsubishi Motors CVT, as it may damage the CVT. Damage caused by the use of fluids other than as recommended is not covered by the Mitsubishi Motors’s New Vehicle Limited Warranty.
- Using fluids that are not Mitsubishi Motors Genuine CVTF-J4 transmission fluid may also damage the CVT. Damage caused by the use of fluids other than as recommended is not covered by the Mitsubishi Motors’s New Vehicle Limited Warranty.

BRAKE FLUID

For additional brake fluid information, see “Capacities and recommended fluids/lubricants” (P.10-2) of this manual.

WARNING

- Use only new fluid from a sealed container. Old, inferior or contaminated fluid may damage the brake system. The use of improper fluids can damage the brake system, and affect the vehicle’s stopping ability.
- Clean the filler cap before removing.
- Brake fluid is poisonous and should be stored carefully in marked containers out of the reach of children.

CAUTION

Do not spill the fluid on any painted surfaces. This will damage the paint. If fluid is spilled, immediately wash the surface with water.

Drain plug tightening torque: 22 to 29 ft-lb (29.4 to 39.2 N·m)

Do not use excessive force.

9. Refill the engine with the recommended oil through the oil filler opening, and install the oil filler cap securely.

See “Capacities and recommended fluids/lubricants” (P.10-2) for drain and refill capacity. The drain and refill capacity depends on the oil temperature and drain time. Use these specifications for reference only. Always use the dipstick to determine the proper amount of oil in the engine.

10. Start the engine and check for leakage around the drain plug and the oil filter. Correct as required.
11. Turn the engine off and wait more than 10 minutes. Check the oil level with the dipstick. Add engine oil if necessary.

After the operation

1. Reinstall undercover in reverse order of removal.
2. Lower the vehicle carefully to the ground.
3. Reset the oil control system (if so equipped) and oil and filter maintenance reminder. (See “Multi-information display” (P.2-21).)

WINDOW WASHER FLUID

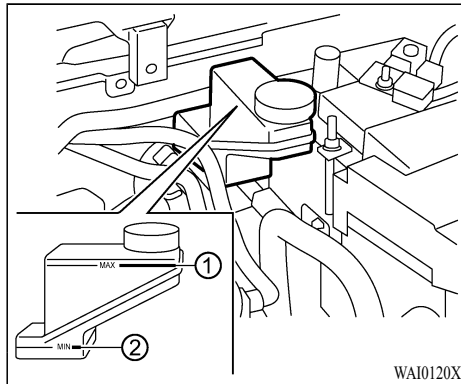

Check the fluid level in the reservoir. If the fluid is below the MIN line ② or the brake warning light comes on, add MITSUBISHI MOTORS GENUINE BRAKE FLUID SUPER4 (DOT 4) or conforming to brake fluid **DOT 3** or **DOT 4** up to the MAX line ①. If fluid must be added frequently, the system should be checked. It is recommended you visit an authorized Mitsubishi Motors dealer for this service.

The reservoir cap must be tightly sealed to keep dirt and water out.

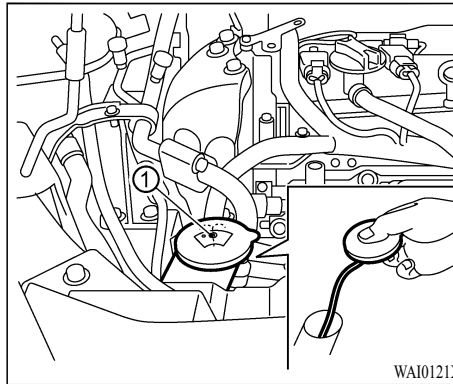

To check the fluid level, use your finger to plug the center hole ① of the cap/tube assembly, then remove it from the reservoir. If there is no fluid in the tube, add fluid.

Add a washer solvent to the washer for better cleaning. In the winter season, add a windshield washer antifreeze. Follow the manufacturer's instructions for the mixture ratio.

Fill the window washer fluid reservoir periodically.

Add fluid when the low washer fluid warning appears.

Refill the reservoir more frequently when driving conditions require an increased amount of window washer fluid.

Recommended fluid:

Mitsubishi Motors genuine Windshield Washer Concentrate Cleaner & Antifreeze or equivalent

CAUTION

- Do not use any fluid other than water fluid. Also, do not use soapy water, glass cleaner, and engine coolant.
- Other liquids could cause streaking on the vehicle's painted surfaces, damage the washer pump, or clog the nozzle, leading to the washer fluid not spraying.
- Over-diluting the washer fluid in winter may cause it to freeze onto the windscreen.

BATTERY

The condition of the battery is very important for quick starting and to keep the vehicle's electrical system working properly. Check the battery regularly.

If battery performance is suspect, have the battery and charging system tested by an authorized Mitsubishi Motors dealer or a repair facility of your choice.

- Keep the battery surface clean and dry. Clean the battery with a solution of baking soda and water.
- Check each battery terminal for corrosion. You can prevent further corrosion by washing with a solution of baking soda and water. Grease the posts and clamps after cleaning or tightening them.
- Make certain the terminal connections are clean and securely tightened.
- If the vehicle is not to be used for 30 days or longer, disconnect the negative \ominus battery terminal cable to prevent discharging it.

NOTE:

Care should be taken to avoid situations that can lead to potential battery discharge and potential no-start conditions such as:

1. **Installation or extended use of electronic accessories that consume battery power when the engine is not running (Phone chargers, GPS, DVD players, etc.)**

2. **Vehicle is not driven regularly and/or only driven short distances.**

In these cases, the battery may need to be charged to maintain battery health.

NOTE:

- **Ensure that the battery is securely installed and cannot be moved. Also check each terminal for tightness.**

WARNING

- Do not expose the battery to flames or electrical sparks. Hydrogen gas generated by the battery is explosive. Do not allow battery fluid to contact your skin, eyes, fabrics or painted surfaces. After touching a battery or battery cap, do not touch or rub your eyes. Thoroughly wash your hands. If the acid contacts your eyes, skin or clothing, immediately flush with water for at least 15 minutes and seek medical attention.
- When working on or near a battery, always wear suitable eye protection and remove all jewelry.
- Battery posts, terminals and related accessories contain lead and lead compounds. Wash hands after handling.
- Keep the battery out of the reach of children.

- Never disconnect the battery while the engine is running, or you could damage the vehicle's electrical parts.

- Never short-circuit the battery. This could cause it to overheat and be damaged.

- Electrolyte (battery acid) is made of corrosive diluted sulfuric acid. If it spills on nearby parts, it can crack, stain, or discolor them. And if it gets on your skin or in your eyes, it can cause burns or blindness. Please observe the following handling instructions:

— If electrolyte gets on plastic parts or other nearby parts, wipe it off with a soft cloth or chamois soaked in a solution of water and neutral detergent then immediately rinse the affected parts with plenty of water.

- Open doors and windows in any closed space where you may be charging or working with the battery.
- In order to prevent a short-circuit, be sure to disconnect the negative (-) terminal first, and reconnect it last.
- Battery posts, terminals and related accessories contain lead and lead compounds. Wash hands after handling.

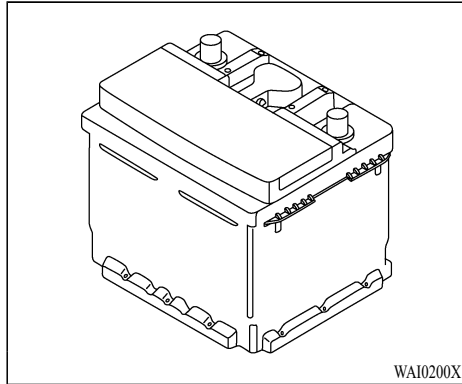
**NOTE:**

Do not try to open the top of the battery.

This battery is not equipped with removable vent caps.

DISCONNECTION AND CONNECTION

To disconnect the battery cable, stop the engine. Disconnect the negative (-) terminal first, then the positive (+) terminal. To reconnect the battery, first connect the positive (+) terminal and then the negative (-) terminal, before starting the vehicle.

NOTE:

- **Open the terminal cover on the positive (+) terminal before disconnecting or connecting the positive (+) terminal of the battery**
- **Loosen the nut of the clamp of the positive (+) terminal and then disconnect the battery cable from the positive (+) terminal.**

JUMP STARTING

If jump starting is necessary, see “Jump starting” (P.6-12). If the engine does not start by jump starting, the battery may have to be replaced. It is recommended you visit an authorized Mitsubishi Motors dealer for this service.

VARIABLE VOLTAGE CONTROL SYSTEM

CAUTION

- **Do not ground accessories directly to the battery terminal. Doing so will bypass the variable voltage control system and the vehicle battery may not charge completely.**
- **Use electrical accessories with the engine running to avoid discharging the vehicle battery.**

The variable voltage control system measures the amount of electrical discharge from the battery and controls voltage generated by the generator.

DRIVE BELT

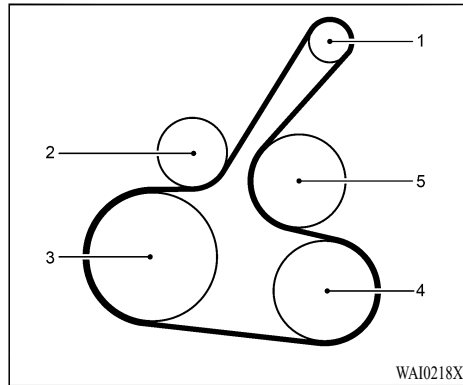

1. Alternator
2. Drive belt auto-tensioner
3. Crankshaft pulley
4. Air conditioner compressor
5. Water pump

WARNING

Be sure the ignition switch is in the OFF or LOCK position before servicing drive belts. The engine could rotate unexpectedly.

1. Visually inspect the belt for signs of unusual wear, cuts or fraying. If the belt is in poor condition, have it replaced. It is recom-

mended you visit an authorized Mitsubishi Motors dealer for this service.

2. Have the belt condition checked regularly.

SPARK PLUGS

WARNING

Be sure the engine and ignition switch are off and that the parking brake is applied.

CAUTION

Be sure to use the correct socket to remove the spark plugs. An incorrect socket can damage the spark plugs.

AIR CLEANER

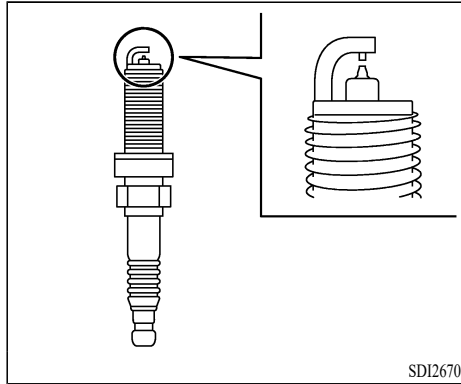

REPLACING SPARK PLUGS

If replacement is required, it is recommended you visit an authorized Mitsubishi Motors dealer for this service.

Iridium platinum-tipped spark plugs

It is not necessary to replace the iridium platinum-tipped spark plugs as frequently as the conventional type spark plugs since they will last much longer. Do not reuse the iridium platinum-tipped spark plugs by cleaning or regapping.

Always replace spark plugs with recommended or equivalent ones.

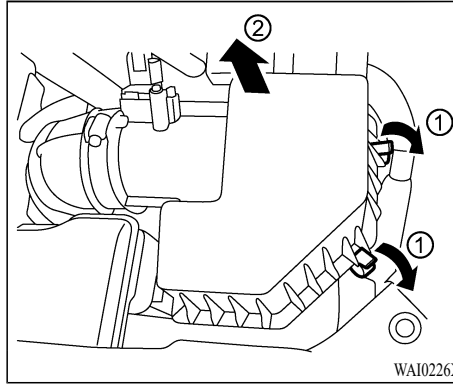

To remove the filter, release the lock pins ① and pull the unit upward ②.

The filter should not be cleaned and reused. Replace the air filter according to the maintenance log shown in a separate maintenance booklet. When replacing the filter, wipe the inside of the air cleaner housing and the cover with a damp cloth.

⚠ WARNING

- Operating the engine with the air cleaner filter off can cause you or others to be burned. The air cleaner filter not only cleans the intake air, it also stops flame if the engine backfires. If the air cleaner

filter is not installed and the engine backfires, you could be burned. Never drive with the air cleaner filter off. Be cautious working on the engine when the air cleaner filter is off.

- Never pour fuel into the throttle body or attempt to start the engine with the air cleaner removed. Doing so could result in serious injury.

WINDSHIELD WIPER BLADES

CLEANING

If your windshield is not clear after using the windshield washer or if a wiper blade chatters when running, wax or other material may be on the blade or windshield.

Clean the outside of the windshield with a washer solution or a mild detergent. Your windshield is clean if beads do not form when rinsing with clear water.

Clean each blade by wiping it with a cloth soaked in a washer solution or a mild detergent. Then rinse the blade with clear water. If your windshield is still not clear after cleaning the blades and using the wiper, replace the blades.

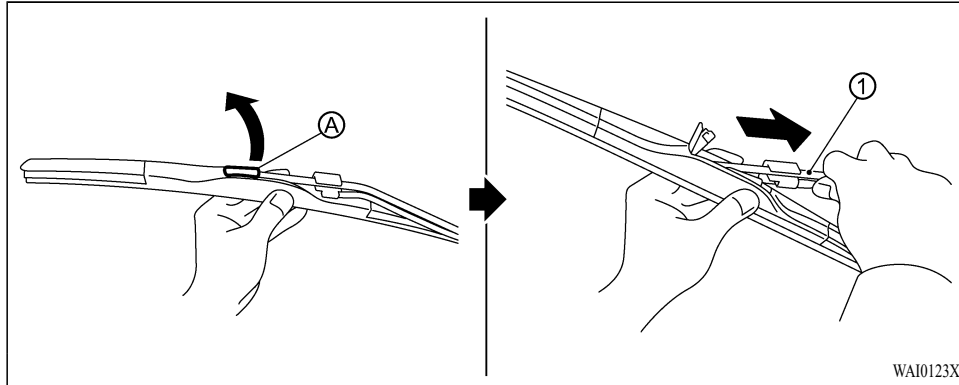

CAUTION

Worn windshield wiper blades can damage the windshield and impair driver vision.



REPLACING

Replace the wiper blades if they are worn.

1. Lift the wiper arm away from the windshield.
2. Pull up the release tab , turn the wiper blade at an angle and then push the wiper blade down in line with the wiper arm  to remove.
3. Insert the new wiper blade onto the wiper arm until a click sounds.
4. Push down the release tab  to lock the wiper blade and put down the wiper arm on the windshield.

CAUTION

- After wiper blade replacement, return the wiper arm to its original position; otherwise it may be damaged when the hood is opened.
- Make sure the wiper blades contact the glass; otherwise the arm may be damaged from wind pressure.

Do-it-yourself 8-15

REAR WINDOW WIPER BLADE BRAKES

It is recommended you contact an authorized Mitsubishi Motors dealer if checking or replacement is required.

If the brakes do not operate properly, it is recommended you have the brakes checked by an authorized Mitsubishi Motors dealer.

SELF-ADJUSTING BRAKES

Your vehicle is equipped with self-adjusting brakes.

The disc-type brakes self-adjust every time the brake pedal is applied.

WARNING

Have your brake system checked if the brake pedal height does not return to normal. It is recommended you visit an authorized Mitsubishi Motors dealer for this service.

BRAKE PAD WEAR WARNING

The disc brake pads have audible wear warnings. When a brake pad requires replacement, it will make a high pitched scraping sound when the vehicle is in motion. This scraping sound will first occur only when the brake pedal is depressed. After more wear of the brake pad, the sound will always be heard even if the brake pedal is not depressed. Have the brakes checked as soon as possible if the wear warning sound is heard.

Under some driving or climate conditions, occasional brake squeak, squeal or other noise

may be heard. Occasional brake noise during light to moderate stops is normal and does not affect the function or performance of the brake system.

Proper brake inspection intervals should be followed.

FUSES

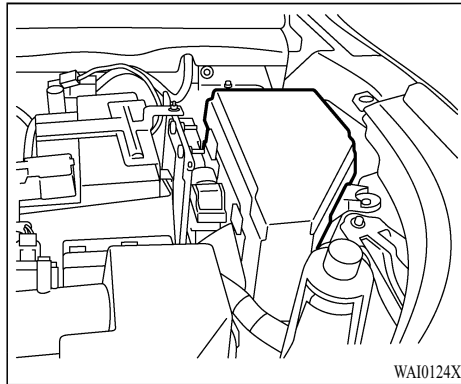

ENGINE COMPARTMENT

WARNING



Never use a fuse of a higher or lower amperage rating than that specified on the fuse box cover. This could damage the electrical system or electronic control units or cause a fire.

If any electrical equipment does not operate, check for an open fuse.

1. Be sure the ignition switch and the headlight switch are turned off.
2. Open the engine hood.

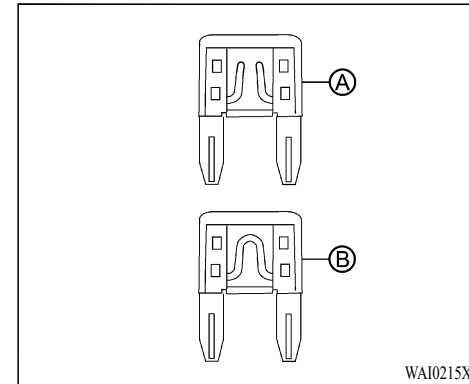
3. Remove the fuse/fusible link box cover by using a suitable tool and pushing the tab.
4. Locate the fuse that needs to be replaced.
5. Remove the fuse using the fuse puller located in the passenger compartment fuse box.



6. If the fuse is open , replace it with a new fuse .
7. If a new fuse also opens, have the electrical system checked and repaired. It is recommended you visit an authorized Mitsubishi Motors dealer for this service.

Fusible links

If any electrical equipment does not operate and the fuses are in good condition, check the fusible links. If any of these fusible links are melted, replace only with genuine Mitsubishi Motors parts.

For checking and replacing the fusible links, it is recommended you visit an authorized

Do-it-yourself 8-17

Mitsubishi Motors dealer.

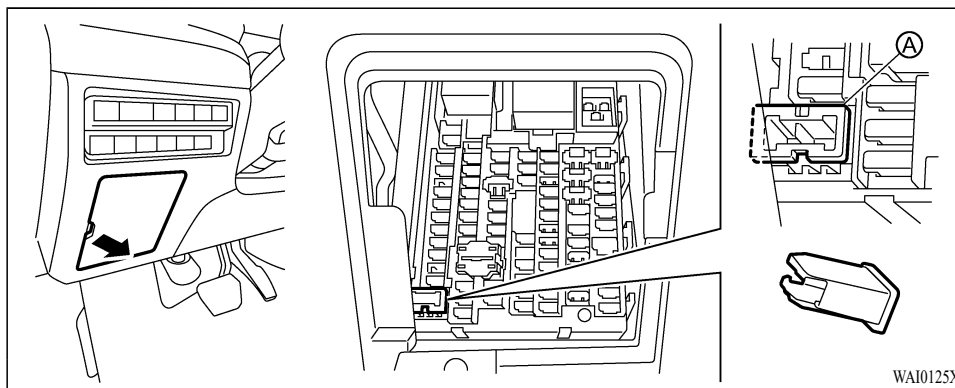

PASSENGER COMPARTMENT



WARNING

Never use a fuse of a higher or lower amperage rating than that specified on the fuse box cover. This could damage the electrical system or electronic control units or cause a fire.

If any electrical equipment does not operate, check for an open fuse.

1. Be sure the ignition switch and the headlight switch are turned off.

2. Remove the fuse box cover.
3. Remove the fuse with the fuse puller (A).

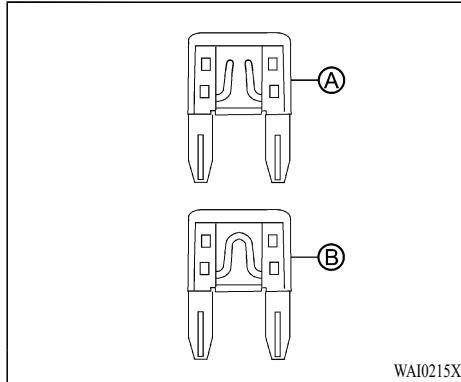

4. If the fuse is open (A), replace it with a new fuse (B).
5. If a new fuse also opens, have the electrical system checked and repaired. It is recommended you visit an authorized Mitsubishi Motors dealer for this service.

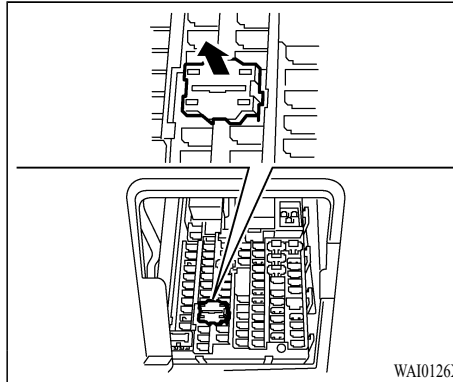

Extended storage fuse switch

To reduce battery drain, the extended storage fuse switch comes from the factory switched off. Prior to delivery of your vehicle, the switch is pushed in (switched on) and should always remain on.

If the extended storage fuse switch is not pushed in (switched on), the meter may display a warning message. See “21. Shipping Mode On Push Storage Fuse warning” (P.2-35).

If any electrical equipment does not operate, remove the extended storage fuse switch and check for an open fuse.

NOTE:

If the extended storage fuse switch malfunctions or if the fuse is open, it is not necessary to replace the switch. In this case, remove the extended storage fuse switch and replace it with a new fuse of the same rating.

How to remove the extended storage fuse switch:

1. To remove the extended storage fuse switch, be sure the ignition switch is in the OFF or LOCK position.
2. Be sure the headlight switch is in the OFF position.
3. Remove the fuse box cover.
4. Pinch and pull out the extended storage fuse switch.
5. Pull the extended storage fuse switch straight out from the fuse box.

F.A.S.T.-KEY BATTERY REPLACEMENT

CAUTION

- Be careful not to allow children to swallow the battery and removed parts.
- An improperly disposed battery can harm the environment. Always confirm local regulations for battery disposal.
- When changing the battery, do not let dust or oil get on the components.
- There is danger of explosion if the lithium battery is incorrectly replaced. Replace only with the same or equivalent type.

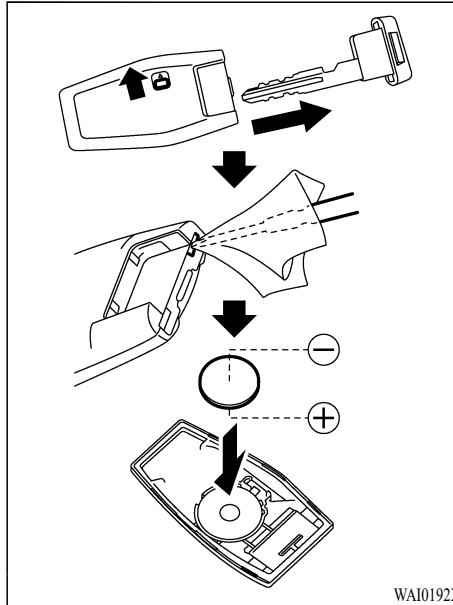

Replace the battery in the F.A.S.T.-key as follows:

1. Remove the emergency key from the F.A.S.T.-key.
2. Insert a small screwdriver into the slit of the corner and twist it to separate the upper part from the lower part. Use a cloth to protect

the casing.

3. Replace the battery with a new one.

Recommended battery:

CR2032 or equivalent

- Do not touch the internal circuit and electric terminals as doing so could cause a malfunction.
- Hold the battery by the edges. Holding the battery across the contact points will seriously deplete the storage capacity.
- Make sure that the \oplus side faces the bottom of the case.

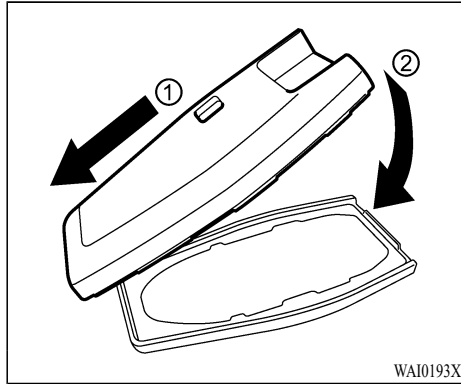

4. Align the tips of the upper and lower parts ①, and then push them together ② until it is securely closed.

5. Operate the buttons to check its operation. If you need any assistance for replacement, it is recommended you visit an authorized Mitsubishi Motors dealer for this service.

FCC Notice:

For USA:

FCC ID: KR5MTXN1

FCC ID: KR5HFM401

This device complies with Part 15 of the FCC Rules. Operation is subject to the following two conditions: (1) this device may not cause

harmful interference, and (2) this device must accept any interference received, including interference that may cause undesired operation. Changes or modifications not expressly approved by the party responsible for compliance could void the user's authority to operate the equipment.

For Canada:

IC: 7812D-MTXN1

IC: 7812D-HFM401

This device complies with Industry Canada licence-exempt RSS standard(s). Operation is subject to the following two conditions: (1) this device may not cause interference, and (2) this device must accept any interference, including interference that may cause undesired operation of the device.

Le présent appareil est conforme aux CNR d'Industrie Canada applicables aux appareils radio exempts de licence. L'exploitation est autorisée aux deux conditions suivantes : (1) l'appareil ne doit pas produire de brouillage, et (2) l'utilisateur de l'appareil doit accepter tout brouillage radioélectrique subi, même si le brouillage est susceptible d'en compromettre le fonctionnement.

LIGHTS

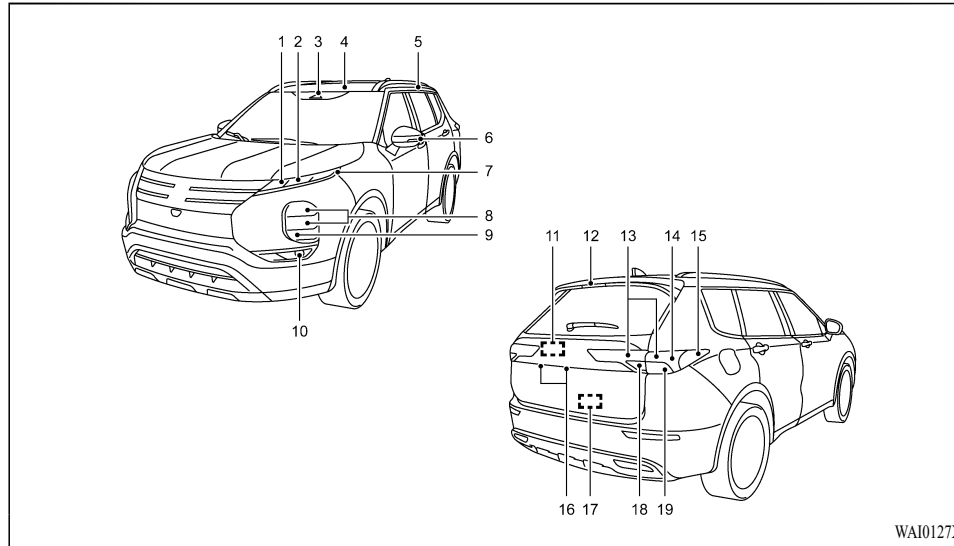

1. Front turn signal light
2. Front parking light/Daytime running light
3. Map light
4. Dome light (if so equipped)
5. Rear personal light (if so equipped)
6. Side turn signal light
7. Front side marker light
8. Headlight (low-beam)
9. Headlight (high-beam)
10. Front fog light (if so equipped)
11. Cargo room light
12. High-mounted stop light
13. Tail light
14. Stop light
15. Rear side marker light
16. License plate light
17. Liftgate light
18. Reverse light
19. Rear turn signal light

HEADLIGHTS

Fog may temporarily form inside the lens of the exterior lights in the rain or in a car wash. A temperature difference between the inside and the outside of the lens causes the fog. This is not a malfunction. If large drops of water collect inside the lens, it is recommended you visit an authorized Mitsubishi Motors dealer for servicing.

Replacing

If LED headlight replacement is required, it is recommended that you visit an authorized Mitsubishi Motors dealer for this service.

Headlight aim adjustment

The alignment of the headlights should be checked by an authorized Mitsubishi Motors dealer or a repair facility of your choice.

EXTERIOR AND INTERIOR LIGHTS



Item	Wattage (W)
Headlight high/low beams*	LED
Front turn signal light*	LED
Front parking light*	LED
Front side marker light*	LED
Front fog light (if so equipped)*	LED
Side turn signal light*	LED
Daytime running light*	LED
Rear turn signal light*	21
Stop/tail light*	LED
Back-up light*	16
Rear side marker light*	LED
License plate light*	LED
Map light*	8

Item	Wattage (W)
Rear personal light (if so equipped)*	5
Dome light (if so equipped)*	8
Vanity mirror light*	5
High-mounted stop light*	LED
Cargo room light	5
Glove box light*	1.4
Liftgate light*	5

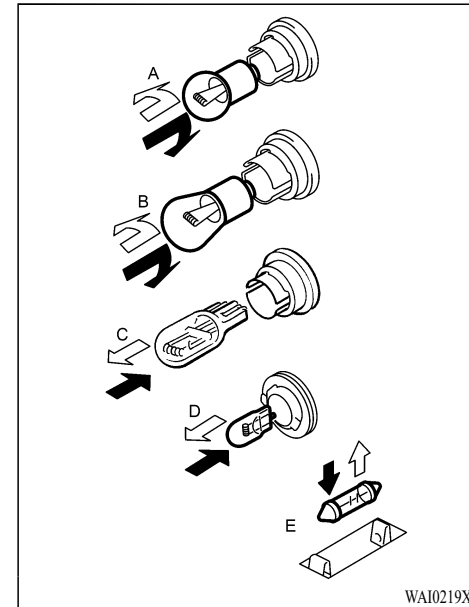
*: It is recommended you visit an authorized Mitsubishi Motors dealer for replacement.



Replacement procedures

- : REMOVE
: INSTALL

All other lights are either type A, B, C, D or E. When replacing a bulb, first remove the lens and/or cover.

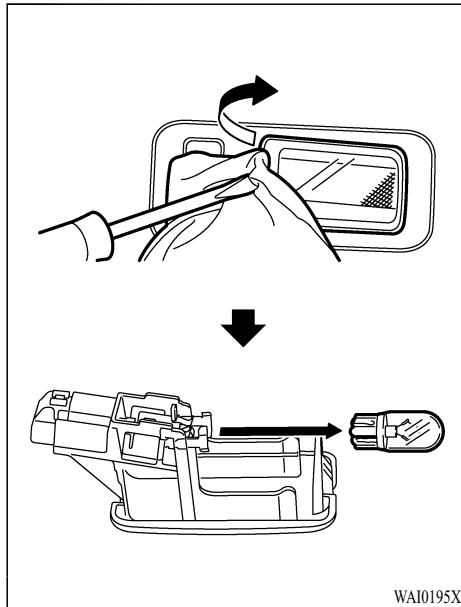

Cargo room light

TIRES

⚠ WARNING

- **Driving with tires that are worn, damaged or improperly inflated is dangerous.**

These type tire conditions will adversely affect vehicle performance.

These type tire conditions can also cause a tread separation or blowout which may result in an accident causing serious injury or death.

- **Tires degrade over time with age even when they are not being used.**

It is recommended that tires over 6 years generally be replaced even if damage is not obvious.

It is important to familiarize yourself with the following terms:

- **Cold tire pressure:**
 - The measured pressure after the vehicle has been parked for at least three hours,
 - or
 - The measured pressure when the vehicle is driven less than 1 mile (1.6 km) after having been parked for three hours.
- **Maximum pressure:** the maximum permissible cold tire inflation pressure for this tire.
- **Recommended inflation pressure:** the inflation pressure for optimum tire performance.
- **Intended outboard sidewall:**
 - The sidewall that contains a whitewall, bears white lettering or bears manufacturer, brand, and/or model name molding that is higher or deeper than the same molding on the other sidewall of the tire,
 - or

- The outward facing sidewall of an asymmetrical tire that has a particular side that must always face outward when mounted on a vehicle.
- Passenger car tire: a tire intended for use on passenger cars, multipurpose passenger vehicles, and trucks that have a gross vehicle weight rating (GVWR) of 10,000 pounds or less.
- Light truck (LT) tire: a tire designated by its manufacturer as primarily intended for use on lightweight trucks or multipurpose passenger vehicles.
- Tread: portion of a tire that comes into contact with the road.
- Tread rib: a tread section running circumferentially around a tire.
- Tread separation: pulling away of the tread from the tire carcass.
- Carcass: the tire structure, except tread and sidewall rubber which, when inflated, bears the load.
- Sidewall: portion of a tire between the tread and bead.
- Section width: the linear distance between the exteriors of the sidewalls of an inflated tire, excluding elevations due to labeling, decoration, or protective bands.
- Bead: the part of the tire that is made of steel wires, wrapped or reinforced by ply cords and that is shaped to fit the rim.
- Ply: a layer of rubber-coated parallel cords.
- Cord: the strands forming the plies in the tire.
- Rim: a metal support for a tire or a tire and tube assembly upon which the tire beads are seated.
- Rim diameter: nominal diameter of the bead seat.
- Groove: the space between two adjacent tread ribs.

TIRE PRESSURE MONITORING SYSTEM (TPMS)

This vehicle is equipped with the Tire Pressure Monitoring System (TPMS). It monitors tire pressure of all tires. When the low tire pressure warning light is lit, and the “Tire Pressure Low - Add Air”/“Tire Pressure Low - Check Cold Tire” warning message is displayed in the multi-information display, one or more of your tires is significantly under-inflated.

The TPMS will activate only when the vehicle is driven at speeds above 16 MPH (25 km/h). Also, this system may not detect a sudden drop in tire pressure (for example a flat tire while driving).

For more details, see “Low tire pressure warning light” (P.2-17), “Tire Pressure Monitoring System (TPMS)” (P.5-6) and “Tire Pressure Monitoring System (TPMS)” (P.6-3).

TIRE CHECKING BEFORE DRIVING

Check all the tires for heavy tread wear or uneven wear patterns. Look for stones, nails, glass, or other objects stuck in the tread. Look for any tread cuts or sidewall cracks. Check the wheel nuts for tightness, and the tires for proper pressure. Replace your tires before they are heavily worn out.

Do-it-yourself 8-25

As your vehicle is equipped with a tire pressure monitoring system (TPMS), there is a risk of damage to the tire inflation pressure sensors when the tire is replaced on the rim. Tire replacement should, only, be performed by a certified Mitsubishi dealer.

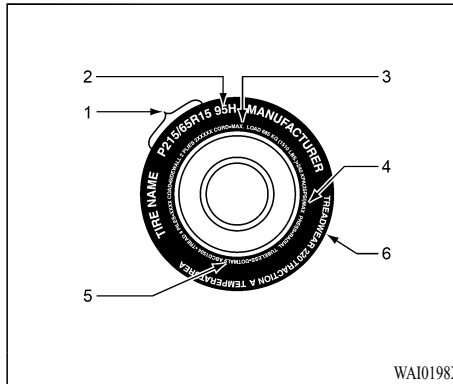

Example

1. Size Designation
2. Service Description
3. Maximum Load
4. Maximum Pressure
5. U.S. DOT Safety Standards Code (TIN)
6. Treadwear, Traction and Temperature Grades

TIRE MARKINGS

Size Designation

EXAMPLE: P215/65R15

P	Passenger car tire size based on U.S.A. design standards
2-15	Section width in millimeters (mm)
65	Aspect ratio in percent (%) Ratio of section height to section width of tire.
R	Construction code •“R” means radial construction. •“D” means diagonal or bias construction.
15	Rim diameter in inches (in)

NOTE:

- **European/Japanese metric tire sizing is based on European/Japanese design standards. Tires designed to these standards have the tire size molded into the sidewall beginning with the section width. The letter “P” is absent from this tire size designa-**

tion.

Example: 215/65R15 96H.

- **LT (Light Truck) -metric tire sizing is based on U.S.A. design standards. The size designation for LT-metric tires is the same as for P-metric tires except for the letters “LT” that are molded into the sidewall preceding the size designation.**

Example: LT235/85R16.

Service Description

EXAMPLE: 95H

95	<p>Load index A numerical code associated with the maximum load a tire can carry.</p>
H	<p>Speed symbol A symbol indicating the range of speeds at which a tire can carry a load corresponding to its load index under certain operating conditions. The maximum speed corresponding to the speed symbol should only be achieved under specified operating conditions. (i.e. tire pressure, vehicle loading, road conditions and posted speed limits)</p>

Maximum Load

Maximum load indicates the maximum load this tire is designed to carry.



WARNING

Overloading of your tire is dangerous. Overloading can cause tire failure, affect vehicle handling, and increase your stopping distance. Use tires of the recommended load capacity for your vehicle. Never overload them.

Maximum Pressure

Maximum Pressure indicates the maximum permissible cold tire inflation pressure for this tire.

Tire Identification Number (TIN)

The TIN may be found on one or both sides of the tire but the date code may only be on one side. Look for the TIN on the outboard side of tires as mounted on the vehicle. If the TIN is

Do-it-yourself 8-27

not found on the outboard side then you will find it on the inboard side of the tire.

EXAMPLE: DOT PP L9 ABCD 1504

D- O- T	Department of Transportation This symbol certifies that the tire is in compliance with the U.S. Department of Transportation tire safety standards, and is approved for highway use.
PP	Code representing the tire manufacturing location. (2 digits)
L9	Code representing the tire size. (1 to 2 digits)
A- B- C- D	Code used by tire manufacturer. (1 to 4 digits)
15	Number representing the week in which the tire was manufactured. (2 digits)
20	Number representing the year in which the tire was manufactured. (2 digits)

EXAMPLE (13 digits type): DOT PPP L9 ABCD 1504

D- O- T	Department of Transportation This symbol certifies that the tire is in compliance with the U.S. Department of Transportation tire safety standards, and is approved for highway use.
P- PP	Code representing the tire manufacturing location. (3 digits)
L9 A- B- C- D	Code used by tire manufacturer. (6 digits)
15	Number representing the week in which the tire was manufactured. (2 digits)
20	Number representing the year in which the tire was manufactured. (2 digits)

Treadwear, Traction and Temperature Grades

Treadwear

The treadwear grade is a comparative rating based on the wear rate of the tire when tested under controlled conditions on a specified government test course. For example, a tire graded 150 would wear one and onehalf (1-1/2) times as well on the government course as a tire graded 100. The relative performance of tires depends upon the actual conditions of their use, however, and may depart significantly from the norm due to variations in driving habits, service practices and differences in road characteristics and climate.

Traction

The traction grades, from highest to lowest, are AA, A, B and C. Those grades represent the tire's ability to stop on wet pavement as measured under controlled conditions on speci-

fied government test surfaces of asphalt and concrete. A tire marked C may have poor traction performance.

Temperature

The temperature grades are A (the highest), B and C, representing the tire's resistance to the generation of heat and its ability to dissipate heat when tested under controlled conditions on a specified indoor laboratory test wheel. Sustained high temperature can cause the material of the tire to degenerate and reduce tire life, and excessive temperature can lead to sudden tire failure. The grade C corresponds to a level of performance which all passenger car tires must meet under the Federal Motor Vehicle Safety Standard No. 109. Grades B and A represent higher levels of performance on the laboratory test wheel than the minimum required by law.

TIRE INFLATION PRESSURES

Proper tire inflation pressure is essential for the safe and satisfactory operation of your vehicle. The wrong tire pressure will cause problems in three major areas:

- Safety
Too little pressure increases flexing in the tire and can cause tire failure. Too much pressure can cause a tire to lose its ability to cushion shock. Objects on the road and potholes could then cause tire damage that may result in tire failure.
- Economy
The wrong tire pressure can cause uneven wear patterns in the tire tread. These abnormal wear patterns will reduce the tread life, and the tire will have to be replaced sooner. Too little pressure also makes it harder for the tire to roll, and this uses up more fuel.
- Ride comfort and vehicle stability
The superior riding experience built

into your vehicle partly depends on the correct tire pressure. Too much pressure gives an uncomfortable and jarring ride. Too little pressure feels as if your vehicle is slow to respond.

Unequal tire pressures can make steering your vehicle uneven and unpredictable.

The tire pressure for your vehicle under normal driving conditions is listed on the placard attached to the driver's door sill.

(Refer to "Tire and loading information placard" (P.10-12).)

The recommended inflation pressures under normal driving conditions should be used for the tires listed below.

Do-it-yourself 8-29

Tire size	Front	Rear
P235/60-R18	240 KPA, 35 PSI	240 KPA, 35 PSI
P255/45-R20		

Tire pressures should be checked, and adjusted if necessary, at least once a month.

Pressures should be checked more often whenever weather temperatures change severely, because tire pressures change with outdoor temperatures. The pressures listed are always “cold inflation pressure”.

Cold inflation pressure is measured after the vehicle has been parked for at least three hours or is driven less than 1 mile (1.6 km) after having been parked for three hours.

Cold inflation pressure must not go above the maximum values molded into the tire sidewall. After driving several miles, your tire inflation pressure may increase 2 to 6 psi (14 to 41

kPa) from the cold inflation pressure. Do not let air out of the tires to get back to the specified cold pressure, or your tires will be too low.

Check your tires each time you refuel. If one tire looks lower than the others, check the pressure for all of them.

You should also take the following safety precautions:

- Keep your tires inflated to the recommended pressures. (See the tire and loading information placard attached to the driver’s door sill.)
- Stay within the recommended load limits.
- Make sure that the weight of any load in your vehicle is evenly distributed.
- Drive at safe speeds.
- After filling your tires to the correct pressure, check them for damage and air leaks. Be sure to reinstall the caps on the valve stems.

REPLACING TIRES AND WHEELS

CAUTION

- Avoid using different size tires from the one listed and the combined use of different types of tires, as this can affect driving safety.

Refer to “Wheels and tires” (P.10-8).

- Always use tires of the same size, same type, and same brand, and which have no wear differences. Using tires that differ in size, type, brand or the degree of wear, will increase the differential oil temperature, resulting in possible damage to the driving system. Further, the drive train will be subjected to excessive loading, possibly leading to oil leakage, component seizure, or other serious problems.
- Only Mitsubishi Motors genuine wheels should be used, because your vehicle is equipped with a tire pressure monitoring system (TPMS).

Use of another type of wheel risks air leaks and sensor damage, as it will not be possible to install the tire pressure sensor properly.

TIRE MAINTENANCE

The following maintenance steps are recommended:

- Check tire pressures regularly.
- Have regular maintenance done on the wheel balance and front and rear suspension alignment.
- Rotate your tires regularly as described in the “Tire rotation” (P.8-31).

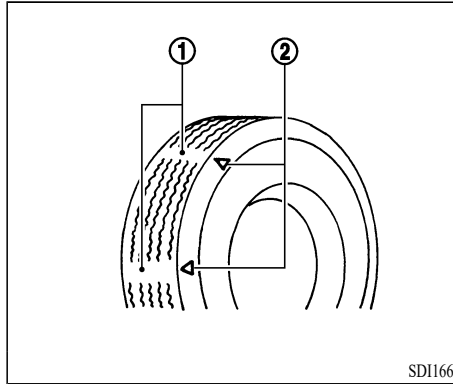

- ① Tread wear indicator
② Location of the tread wear indicator

TREAD WEAR INDICATOR

Tread wear indicators are built into the original equipment tires on your vehicle to help you know when your tires should be replaced. Many states have laws requiring that you replace your tires at this point.

These indicators are molded into the bottom of the tread grooves and will appear when the tire tread is worn down to 1/16 inch (1.6 mm).

When the bands appear next to one another in two or more places, replace your tires.

NOTE:

Tire wear indicators can have different marks and locations depending on the tire manufacturer.

TIRE ROTATION

To even out the wear on your tires and make them last longer, Mitsubishi Motors Corporation recommends that you rotate your tires at the mileage listed in the “WARRANTY AND MAINTENANCE MANUAL”.

However, the timing for tire rotation may vary according to your vehicle condition, road surface conditions, and your own personal driving habits. Any time you notice unusual wear, rotate your tires as soon as possible.

When rotating tires, check for uneven wear, damage, and wheel alignment. Abnormal wear is usually caused by a wrong tire pressure, wheels that are not aligned properly, wheels that are out-of-balance, or severe braking.

Check with a certified Mitsubishi dealer to find out the reason for uneven

Do-it-yourself 8-31

tread wear.

The first tire rotation is the most important one. It will allow all your tires to wear evenly.

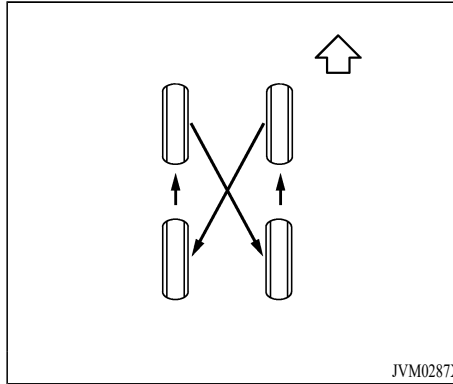

Tires that do not have arrows showing rotation direction

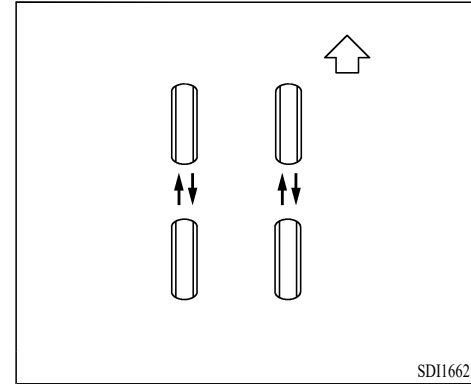

Tires that have arrows showing rotation direction

CAUTION

If the tires have arrows (A) indicating the correct direction of rotation, swap the front and rear tires on the left-hand side of the vehicle and the front and rear tires on the right-hand side of the vehicle separately. Keep each tire on its original side of the vehicle. When installing the tires, make sure the arrows point in the

direction in which the wheels will turn when the vehicle moves forward. Any tire whose arrow points in the wrong direction will not perform to its full potential.

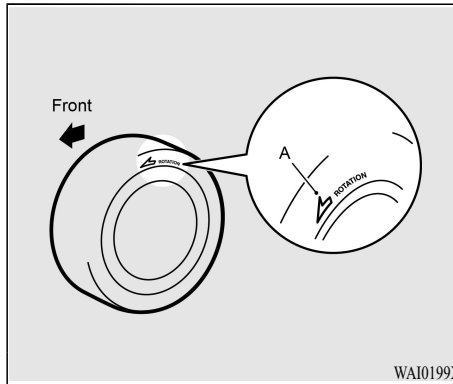

CAUTION

Avoid the combined use of different types of tires. Using different types of tires can affect vehicle performance and safety.

SNOW TIRES

In some areas of the country, snow tires are required for winter driving. If snow tires are required in your area, you must choose snow tires of the same size and type as the original tires provided with your vehicle. Snow tires should also be installed on all four wheels. Otherwise your safety and vehicle handling can be reduced.

Even where laws may permit it, snow tires should not be operated at sustained speeds over 75 MPH (120 km/h).

CAUTION

Only Mitsubishi Motors genuine wheels should be used, because your vehicle is equipped with a tire pressure monitoring system (TPMS).

Use of another type of wheel risks air leaks and sensor damage, as it will not be possible to install the tire pressure sensor properly.

TIRE CHAINS

CAUTION

Tire chains cannot be used on your vehicle. The clearance between the chains and the body is not sufficient to allow proper clearance, and

(486,1)

the vehicle body might be damaged.

8-34 Do-it-yourself

Condition:

[Edit: 2021/ 2/ 10 Model: DG-D]

9 Maintenance and schedules

Maintenance requirement	9-2	Where to go for service	9-2
General maintenance	9-2	General maintenance	9-2
Scheduled maintenance	9-2	Explanation of general maintenance items	9-2

MAINTENANCE REQUIREMENT

Some day-to-day and regular maintenance is essential to maintain your vehicle good mechanical condition, as well as its emission and engine performance.

It is the owner's responsibility to make sure that the scheduled maintenance, as well as general maintenance, is performed.

As the vehicle owner, you are the only one who can ensure that your vehicle receives the proper maintenance care. You are a vital link in the maintenance chain.

GENERAL MAINTENANCE

General maintenance includes those items which should be checked during normal day-to-day operation. They are essential for proper vehicle operation. It is your responsibility to perform these procedures regularly as prescribed.

Performing general maintenance checks requires minimal mechanical skill and only a few general automotive tools.

These checks or inspections can be done by yourself, a qualified technician or, if you prefer, an authorized Mitsubishi Motors dealer.

SCHEDULED MAINTENANCE

The maintenance items listed in this section are required to be serviced at regular intervals. However, under severe driving conditions, additional or more frequent maintenance will be required.

WHERE TO GO FOR SERVICE

If maintenance service is required or your vehicle appears to malfunction, have the systems checked and serviced. It is recommended you visit an authorized Mitsubishi Motors dealer for this service.

Mitsubishi Motors technicians are well-trained specialists and are kept up-to-date with the latest service information through technical bulletins, service tips, and training programs. They are completely qualified to work on Mitsubishi Motors vehicles **before** work begins.

If your vehicle is involved in a collision, it is recommended that you ask your authorized Mitsubishi Motors dealer.

You can be confident that an authorized Mitsubishi Motors dealer's service department performs the best job to meet the maintenance requirements on your vehicle.

GENERAL MAINTENANCE

During the normal day-to-day operation of the vehicle, general maintenance should be performed regularly as prescribed in this section. If you detect any unusual sounds, vibrations or smells, be sure to check for the cause or have it checked promptly. In addition, it is recommended that you visit an authorized Mitsubishi Motors dealer if you think that repairs are required.

When performing any checks or maintenance work, see "Maintenance precautions" (P.8-2).

EXPLANATION OF GENERAL MAINTENANCE ITEMS

Additional information on the following items with "*" is found in the "8. Do-it-yourself" section of this manual.

Outside the vehicle

The maintenance items listed here should be performed from time to time, unless otherwise specified.

Doors and engine hood: Check that all doors and the engine hood operate properly. Also ensure that all latches lock securely. Lubricate hinges, latches, latch pins, rollers and links if necessary. Make sure that the secondary latch keeps the hood from opening when the primary latch is released.

When driving in areas using road salt or other

corrosive materials, check lubrication frequently.

Lights*: Clean the headlights on a regular basis. Make sure that the headlights, stop lights, tail lights, turn signal lights, and other lights are all operating properly and installed securely. Also check headlight aim.

Road wheel nuts (lug nuts)*: When checking the tires, make sure no wheel nuts are missing, and check for any loose wheel nuts. Tighten if necessary.

Tire rotation*: Tires should be rotated every 7,500 miles (12,000 km).

Tires*: Check the pressure with a gauge often and always prior to long distance trips. If necessary, adjust the pressure in all tires to the pressure specified. Check carefully for damage, cuts or excessive wear.

Tire Pressure Monitoring System (TPMS) transmitter components: Replace the TPMS transmitter valve when the tires are replaced due to wear or age.

Wheel alignment and balance: If the vehicle should pull to either side while driving on a straight and level road, or if you detect uneven or abnormal tire wear, there may be a need for wheel alignment.

If the steering wheel or seat vibrates at normal highway speeds, wheel balancing may be

needed.

For additional information regarding tires, refer to “Important Tire Safety Information” (US) or “Tire Safety Information” (Canada) in the Mitsubishi Motors Warranty and Maintenance Manual.

Windshield: Clean the windshield on a regular basis. Check the windshield at least every six months for cracks or other damage. Have a damaged windshield replaced by a qualified repair facility.

It is recommended that you have a damaged windshield replaced by an authorized Mitsubishi Motors dealer.

Windshield wiper blades*: Check for cracks or wear if they do not wipe properly.

Inside the vehicle

The maintenance items listed here should be checked on a regular basis, such as when performing scheduled maintenance, cleaning the vehicle, etc.

Accelerator pedal: Check the pedal for smooth operation and make sure the pedal does not catch or require uneven effort. Keep the floor mat away from the pedal.

Brake pedal: Check the pedal for smooth operation. If the brake pedal suddenly goes down further than normal, the pedal feels

spongy or the vehicle seems to take longer to stop, have your vehicle checked immediately. It is recommended you visit an authorized Mitsubishi Motors dealer for this service. Keep the floor mat away from the pedal.

Brakes: Check that the brakes do not pull the vehicle to one side when applied.

Continuously Variable Transmission (CVT) P (Park) mechanism: On a fairly steep hill, check that the vehicle is held securely with the shift lever in the P (Park) position without applying any brakes.

Parking brake: Check the parking brake operation regularly. The vehicle should be securely held on a fairly steep hill with only the parking brake applied. If the parking brake needs adjusted, it is recommended you visit an authorized Mitsubishi Motors dealer for this service.

Seat belts: Check that all parts of the seat belt system (for example, buckles, anchors, adjusters and retractors) operate properly and smoothly, and are installed securely. Check the belt webbing for cuts, fraying, wear or damage.

Seats: Check seat position controls such as seat adjusters, seatback recliners, etc. to ensure they operate smoothly and that all latches lock securely in every position. Check that the head restraints move up and down smoothly and that the locks (if so equipped) hold securely in all

latched positions.

Steering wheel: Check for changes in the steering conditions, such as excessive free play, hard steering or strange noises.

Warning lights and chimes: Make sure that all warning lights and chimes are operating properly.

Windshield defroster: Check that the air comes out of the defroster outlets properly and in sufficient quantity when operating the heater or air conditioner.

Windshield wiper and washer*: Check that the wipers and washers operate properly and that the wipers do not streak.

Under the hood and vehicle

The maintenance items listed here should be checked periodically (for example, each time you check the engine oil or refuel).

Battery*:

NOTE:

Care should be taken to avoid situations that can lead to potential battery discharge and potential no-start conditions such as:

1. **Installation or extended use of electronic accessories that consume battery power when the engine is not running (Phone chargers, GPS, DVD players, etc.)**

2. **Vehicle is not driven regularly and/or only driven short distances.**

In these cases, the battery may need to be charged to maintain battery health.

Brake and clutch fluid level*: Make sure that the brake and clutch fluid level is between the MAX and MIN lines on the reservoir.

Engine coolant level*: Check the coolant level when the engine is cold after parking the vehicle on a level surface.

Engine drive belt*: Make sure that the drive belt is not frayed, worn, cracked or oily.

Engine oil level*: Check the level after parking the vehicle on a level surface and turning off the engine. Wait more than 10 minutes for the oil to drain back into the oil pan.

Exhaust system: Make sure there are no loose supports, cracks or holes. If the sound of the exhaust seems unusual or there is a smell of exhaust fumes, immediately have the exhaust system inspected. It is recommended you visit an authorized Mitsubishi Motors dealer for this service. (See “Precautions when starting and driving” (P.5-5) for exhaust gas (carbon monoxide).)

Fluid leaks: Check under the vehicle for fuel, oil, water or other fluid leaks after the vehicle has been parked for a while. Water dripping from the air conditioner after use is normal. If

you should notice any leaks or if gasoline fumes are evident, check for the cause and have it corrected immediately.

Radiator and hoses: Check the front of the radiator and clean off any dirt, insects, leaves, etc., that may have accumulated. Make sure the hoses have no cracks, deformation, rot or loose connections.

Underbody: The underbody is frequently exposed to corrosive substances such as those used on icy roads or to control dust. It is very important to remove these substances, otherwise rust will form on the floor pan, frame, fuel lines and around the exhaust system. At the end of winter, the underbody should be thoroughly flushed with plain water, being careful to clean those areas where mud and dirt may accumulate. For additional information, see “Cleaning exterior” (P.7-2).

Windshield washer fluid*: Check that there is adequate fluid in the reservoir.

10 Technical and consumer information/Reporting Safety Defects

Capacities and recommended fluids/lubricants	10-2	Securing the load	10-18
Fuel information	10-3	Loading tips	10-18
Engine oil and oil filter recommendation	10-5	Measurement of weights	10-19
Air conditioning system refrigerant and lubricant recommendations	10-6	Towing a trailer	10-19
Specifications	10-7	Maximum load limits	10-20
Engine	10-7	Maximum Gross Vehicle Weight (GVW)/ maximum Gross Axle Weight (GAW)	10-21
Wheels and tires	10-8	Towing load/specification	10-22
Dimensions and weights	10-9	Towing safety	10-23
Battery	10-10	Flat towing	10-29
When traveling or registering in another country	10-11	Flat towing for All-Wheel Control vehicle (if so equipped)	10-29
Vehicle identification	10-11	Flat towing for Front-Wheel Drive vehicle (if so equipped)	10-29
Vehicle Identification Number (VIN) plate	10-11	Uniform tire quality grading	10-30
Vehicle identification number (chassis number)	10-11	Treadwear	10-30
Engine serial number	10-12	Traction AA, A, B and C	10-30
F.M.V.S.S./C.M.V.S.S. certification label	10-12	Temperature A, B and C	10-30
Emission control information label	10-12	Emission control system warranty	10-31
Tire and loading information placard	10-12	Reporting Safety Defects	10-31
Air conditioner specification label	10-13	Readiness for Inspection/Maintenance (I/M) test	10-33
Vehicle loading information	10-15	Event Data Recorders (EDR)	10-34
Terms	10-15	Additional data recording	10-34
Vehicle load capacity	10-16		



CAPACITIES AND RECOMMENDED FLUIDS/LUBRICANTS

The following are approximate capacities. The actual refill capacities may be a little different. When refilling, follow the procedure instructed in the “8. Do-it-yourself” section to determine the proper refill capacity.

Fluid type		Capacity (approximate)			Recommended Fluids/Lubricants
		Metric Measure	US Measure	Imperial Measure	
Fuel		55 L	14-1/2 gal	12-1/8 gal	· See “Fuel information” (P.10-3).
Engine oil ^{*1} Drain and refill ^{*1} : For additional information, see “Changing engine oil and filter” (P.8-6).	With oil filter change	5.1 L	5-3/8 qt	4-1/2qt	· Genuine “MITSUBISHI MOTORS GENUINE MOTOR OIL SN 0W-20” (or equivalent) is recommended. · If the above motor oil (or engine oil) is not available, a synthetic 0W-20 GF-5 SN motor oil (or engine oil) may be used. Damage caused by the use of motor oil (or engine oil) other than as recommended is not covered under Mitsubishi Motor’s New Vehicle Limited warranty. For additional information, see “Engine oil and oil filter recommendation” (P.10-5).
	Without oil filter change	4.8 L	5-1/8 qt	4-1/4qt	
Engine coolant	With reservoir	9.4 L	9-9/10 qt	8-3/10 qt	· MITSUBISHI MOTORS GENUINE SURPER LONG LIFE COOLANT PREMIUM or equivalent
	Reservoir	0.8 L	7/8 qt	3/4 qt	
Continuously Variable Transmission (CVT) fluid		7.9L	8-1/4qt	7qt	· MITSUBISHI MOTORS GENUINE CVTF-J4 · Use only “Mitsubishi Motors Genuine CVTF-J4” transmission fluid to ensure optimum transmission performance.
Differential gear oil		0.5 L	1/8 gal	1/9 gal	· Genuine NISSAN HYPOID FLUID-S1 GL-5 75W-80 or equivalent
Transfer fluid		0.3 L	1/3 qt	2/7 qt	· Genuine NISSAN Differential Oil Hypoid Super-S GL-5 synthetic 75W-90 or equivalent
Brake fluid		Refill to the proper oil level according to the instructions in the “8. Do-it-yourself” section.			· MITSUBISHI MOTORS GENUINE BRAKE FLUID SUPER4 (DOT 4) or conforming to brake fluid DOT 3 or DOT 4
Multi-purpose grease		—	—	—	· NLGI No. 2 (Lithium soap base)
Air conditioning system refrigerant		—	—	—	· See “Air conditioner specification label” (P.10-13) for air conditioner specification label. · HFO-1234yf (R-1234yf)
Window washer fluid	Model without headlight cleaner	2.5 L	5/8 gal	1/2 gal	· Mitsubishi Motors genuine Windshield Washer Concentrate Cleaner & Antifreeze or equivalent
	Model with headlight cleaner	3.5 L	7/8 gal	3/4 gal	
Coupling oil		0.6 L	1/6 gal	1/8 gal	· LSC Transmission Fluid 12-301

10-2 Technical and consumer information/Reporting Safety Defects

FUEL INFORMATION

Use unleaded regular gasoline with an octane rating of at least 87 AKI (Anti-Knock Index) number (Research octane number 91).

CAUTION

- Using a fuel other than that specified could adversely affect the emission control system, and may also affect warranty coverage.
- Under no circumstances should a leaded gasoline be used, because this will damage the three-way catalyst.
- Do not use a fuel containing more than 15% ethanol in your vehicle. Your vehicle is not designed to run on a fuel containing more than 15% ethanol. Using a fuel containing more than 15% ethanol in a vehicle not specifically designed for a fuel containing more than 15% ethanol can adversely affect the emission control devices and systems of the vehicle. Damage caused by such fuel is not covered by the Mitsubishi Motors new vehicle limited warranty.
- Do not use fuel that contains the octane booster methylcyclopentadienyl manganese tricarbonyl (MMT). Using fuel containing MMT may adversely affect vehicle performance and vehicle emissions. Not all

fuel dispensers are labeled to indicate MMT content, so you may have to consult your gasoline retailer for more details. Note that Federal and California laws prohibit the use of MMT in reformulated gasoline.

- U.S. government regulations require ethanol dispensing pumps to be identified by a small, square, orange and black label with the common abbreviation or the appropriate percentage for that region.

Gasoline specifications

Mitsubishi Motors recommends using gasoline that meets the World-Wide Fuel Charter (WWFC) specifications where it is available. Many of the automobile manufacturers developed this specification to improve emission control system and vehicle performance. Ask your service station manager if the gasoline meets the WWFC specifications.

Reformulated gasoline

Some fuel suppliers are now producing reformulated gasolines. These gasolines are specially designed to reduce vehicle emissions. Mitsubishi Motors supports efforts towards cleaner air and suggests that you use reformulated gasoline when available.

Gasoline containing oxygenates

Some fuel suppliers sell gasoline containing oxygenates such as ethanol, MTBE and methanol with or without advertising their presence. Mitsubishi Motors does not recommend the use of fuels of which the oxygenate content and the fuel compatibility for your vehicle cannot be readily determined. If in doubt, ask your service station manager.

If you use oxygenate-blend gasoline, please take the following precautions as the usage of such fuels may cause vehicle performance problems and/or fuel system damage.

- The fuel should be unleaded and have an octane rating no lower than that recommended for unleaded gasoline.
- If an oxygenate-blend, other than methanol blend is used, it should contain no more than 10% oxygenate. (MTBE may, however, be added up to 15%.)
- If a methanol blend is used, it should contain no more than 5% methanol (methyl alcohol, wood alcohol). It should also contain a suitable amount of appropriate cosolvents and corrosion inhibitors. If not properly formulated with appropriate cosolvents and corrosion inhibitors, such methanol blends may cause fuel system damage and/or vehicle performance problems. At this time,

sufficient data is not available to ensure that all methanol blends are suitable for use in Mitsubishi Motors vehicles.

If any driveability problems such as engine stalling and difficult hot-starting are experienced after using oxygenate-blend fuels, immediately change to a non-oxygenate fuel or a fuel with a low blend of MTBE.

Take care not to spill gasoline during refueling. Gasoline containing oxygenates can cause paint damage.

E-15 fuel

E-15 fuel is a mixture of approximately 15% fuel ethanol and 85% unleaded gasoline. E-15 can only be used in vehicles designed to run on E-15 fuel. U.S. government regulations require fuel ethanol dispensing pumps to be identified with small, square, orange and black label with the common abbreviation or the appropriate percentage for that region.

E-85 fuel

E-85 fuel is a mixture of approximately 85% fuel ethanol and 15% unleaded gasoline. E-85 can only be used in a Flexible Fuel Vehicle (FFV). Do not use E-85 fuel in your vehicle. U.S. government regulations require fuel ethanol dispensing pumps to be identified by a small, square, orange and black label with the common abbreviation or the appropriate per-

centage for that region.

Fuel containing MMT

MMT, or methylcyclopentadienyl manganese tricarbonyl, is an octane boosting additive. Mitsubishi Motors does not recommend the use of fuel containing MMT. Such fuel may adversely affect vehicle performance, including the emissions control system. Note that while some fuel pumps label MMT content, not all do, so you may have to consult your gasoline retailer for more details.

Aftermarket fuel additives

Mitsubishi Motors does not recommend the use of any aftermarket fuel additives (for example, fuel injector cleaner, octane booster, intake valve deposit removers, etc.) which are sold commercially. Many of these additives intended for gum, varnish or deposit removal may contain active solvent or similar ingredients that can be harmful to the fuel system and engine.

Octane rating tips

Using unleaded gasoline with an octane rating lower than recommended can cause persistent, heavy “spark knock”. (Spark knock is a metallic rapping noise.) If severe, this can lead to engine damage. If you detect a persistent heavy spark knock even when

using gasoline of the stated octane rating, or if you hear steady spark knock while holding a steady speed on level roads, it is recommended you have an authorized Mitsubishi Motors dealer correct the condition. Failure to correct the condition is misuse of the vehicle, for which Mitsubishi Motors is not responsible.

Incorrect ignition timing will result in spark knock, after-run and/or overheating, which may cause excessive fuel consumption or engine damage. If any of the above symptoms are encountered, have your vehicle checked. It is recommended you visit an authorized Mitsubishi Motors dealer for servicing.

However, now and then you may notice light spark knock for a short time while accelerating or driving up hills. This is not a cause for concern, because you get the greatest fuel benefit when there is light spark knock for a short time under heavy engine load.

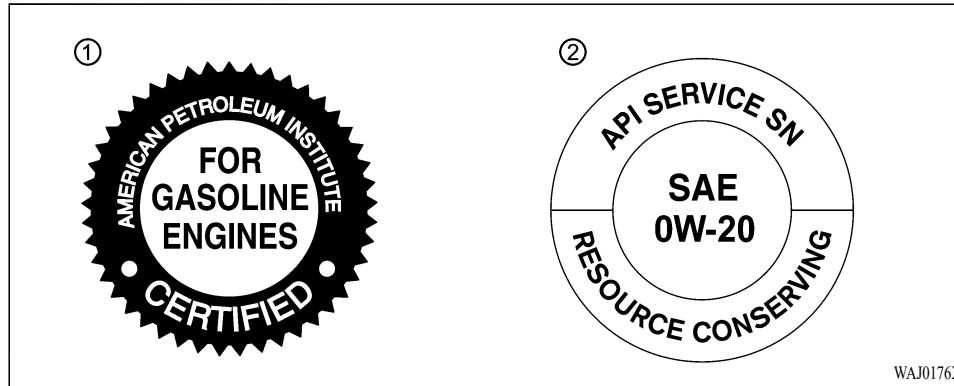

- ① ILSAC certification symbol
 ② API service symbol

ENGINE OIL AND OIL FILTER RECOMMENDATION

Selecting the correct oil

It is essential to choose the correct grade, quality, and viscosity engine oil to ensure satisfactory engine life and performance, see “Capacities and recommended fluids/lubricants” (P.10-2). Mitsubishi Motors recommends the use of an energy conserving oil in order to improve fuel economy.

Select only engine oils that meet the American Petroleum Institute (API) certification or Inter-

national Lubricant Standardization and Approval Committee (ILSAC) certification and SAE viscosity standard. These oils have the API certification mark on the front of the container. Oils which do not have the specified quality label should not be used as they could cause engine damage.

Oil additives

Mitsubishi Motors does not recommend the use of oil additives. The use of an oil additive is not necessary when the proper oil type is used and maintenance intervals are followed.

Oil which may contain foreign matter or has been previously used should not be used.

Oil viscosity

The engine oil viscosity or thickness changes with temperature. Because of this, it is important to select the engine oil viscosity based on the temperatures at which the vehicle will be operated before the next oil change. Choosing an oil viscosity other than that recommended could cause serious engine damage.

Selecting the correct oil filter

Your new Mitsubishi Motors vehicle is equipped with a high-quality genuine Mitsubishi Motors oil filter. When replacing, use a genuine Mitsubishi Motors oil filter or its equivalent for the reason described in “Change intervals”.

Change intervals

The oil and oil filter change intervals for your engine are based on the use of the specified quality oils and filters. Using an engine oil and filter other than the specified quality, or exceeding recommended oil and filter change intervals could reduce engine life. Damage to the engine caused by improper maintenance or use of incorrect oil and filter quality and/or viscosity is not covered by the Mitsubishi Motors new vehicle limited warranty.

Your engine was filled with a high quality engine oil when it was built. You do not have to

change the oil before the first recommended change interval.

Oil and filter change intervals depend upon how you use your vehicle. Operation under the following conditions may require more frequent oil and filter changes:

- repeated short distance driving at cold outside temperatures
- driving in dusty conditions
- extensive idling
- stop and go commuting

(See “Maintenance and schedules” (P.9-1).)

AIR CONDITIONING SYSTEM REFRIGERANT AND LUBRICANT RECOMMENDATIONS

The air conditioning system in your Mitsubishi Motors vehicle must be charged with the specified refrigerant and compressor oil or equivalent. See the air conditioner specification label. (See “Air conditioner specification label” (P.10-13).)

- HFO-1234yf (R-1234yf)
- A/C system oil ND-OIL12(PAG) or equivalent



CAUTION

The use of any other refrigerant or oil may cause severe damage to the air conditioning system and may require the replacement of all air conditioner system components.

The refrigerant HFO-1234yf (R-1234yf) in your Mitsubishi Motors vehicle will not harm the earth’s ozone layer. Although this refrigerant does not affect the earth’s atmosphere, certain governmental regulations require the recovery and recycling of any refrigerant during automotive air conditioning system service. A authorized Mitsubishi Motors dealer has the trained technicians and equipment needed to recover and recycle your air conditioning system refrigerant.

It is recommended you visit an authorized Mitsubishi Motors dealer when servicing your air conditioning system.

SPECIFICATIONS

ENGINE

Model		PR25DD
Type		Gasoline, 4-cycle, DOHC
Cylinder arrangement		4-cylinder, in-line
Bore × Stroke	in (mm)	3.504 × 3.937 (89.0 × 100.0)
Displacement	cu in (cm ³)	151.85 (2,488)
Firing order		1-3-4-2
Idle speed	rpm	
Ignition timing (B.T.D. C.)	degree/rpm	No adjustment is necessary.
Spark plug	Standard	DXE22H11C
Spark plug gap (Normal)	in (mm)	0.043 (1.1)
Camshaft operation		Timing chain

This spark ignition system complies with the Canadian standard ICES-002.

WHEELS AND TIRES

Road wheel

Type	Size	Offset (Inset) in (mm)
Conventional	18 x 7.5J	1.38 (35)
	20 x 8J	1.38 (35)
Spare		-

Tire

Type	Size	Pressure PSI (kPa) [Cold]
Conventional	P235/60R18 102H	35 (240)
	P255/45R20 101W	
Spare		-

10-8 Technical and consumer information/Reporting Safety Defects

DIMENSIONS AND WEIGHTS

Overall length	in (mm)	185.4 (4,710)
Overall width	in (mm)	73.3 (1,862)
Overall height	in (mm)	68.8 (1,748)
Front tread	in (mm)	62.7 (1,593)
Rear tread	in (mm)	63.1 (1,602)
Wheelbase	in (mm)	106.5 (2,706)
Gross Vehicle Weight Rating (GVWR)	lb (kg)	
Gross Axle Weight Rating (GAWR)		See the F.M.V.S.S. or C.M.V.S.S. certification label on the driver's side center pillar.
Front	lb (kg)	
Rear	lb (kg)	
Seating capacity		7 persons

BATTERY

Battery	Type	L3-EFB
	Capacity (20HR)	70 Ah
	CCA (EN)	720 A

10-10 **Technical and consumer information/Reporting Safety Defects**

Condition:

[Edit: 2021/ 2/ 10 Model: DG-D]

WHEN TRAVELING OR REGISTERING IN ANOTHER COUNTRY

When planning to travel in another country, you should first find out if the fuel available is suitable for your vehicle's engine.

Using fuel with an octane rating that is too low may cause engine damage. All gasoline vehicles must be operated with unleaded gasoline. Therefore, avoid taking your vehicle to areas where appropriate fuel is not available.

When transferring the registration of your vehicle to another country, state, province or district, it may be necessary to modify the vehicle to meet local laws and regulations.

The laws and regulations for motor vehicle emission control and safety standards vary according to the country, state, province or district; therefore, vehicle specifications may differ.

When any vehicle is to be taken into another country, state, province or district and registered, its modifications, transportation, and registration are the responsibility of the user. Mitsubishi Motors is not responsible for any inconvenience that may result.

VEHICLE IDENTIFICATION

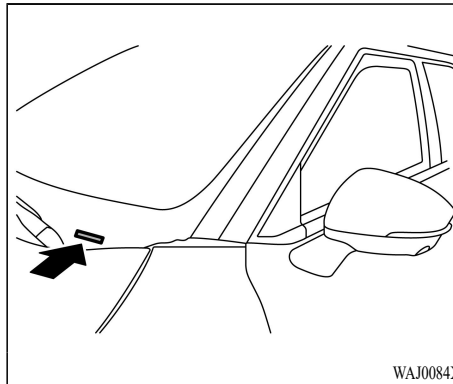

VEHICLE IDENTIFICATION NUMBER (VIN) PLATE

The vehicle identification number plate is attached as shown. This number is the identification for your vehicle and is used in the vehicle registration.

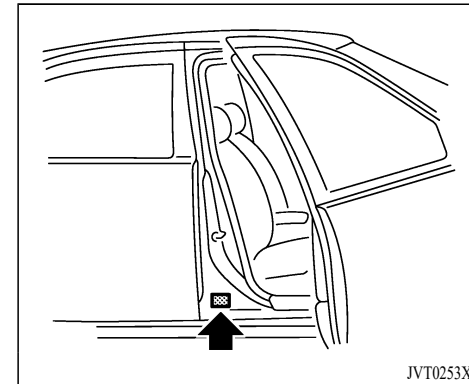

VEHICLE IDENTIFICATION NUMBER (chassis number)

The vehicle identification number is located as shown.

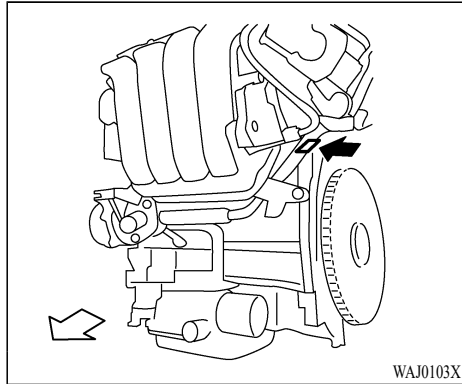

ENGINE SERIAL NUMBER

The number is stamped on the engine as shown.

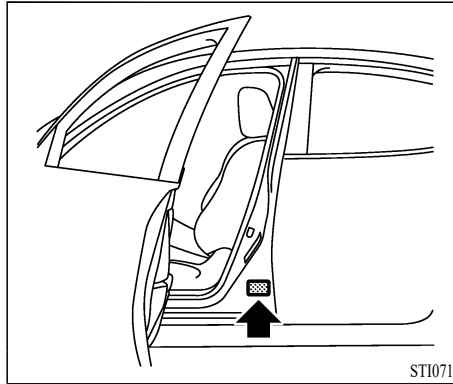

F.M.V.S.S./C.M.V.S.S. CERTIFICATION LABEL

The Federal/Canadian Motor Vehicle Safety Standards (F.M.V.S.S./C.M.V.S.S.) certification label is affixed as shown. This label contains valuable vehicle information, such as: Gross Vehicle Weight Ratings (GVWR), Gross Axle Weight Rating (GAWR), month and year of manufacture, Vehicle Identification Number (VIN), etc. Review it carefully.

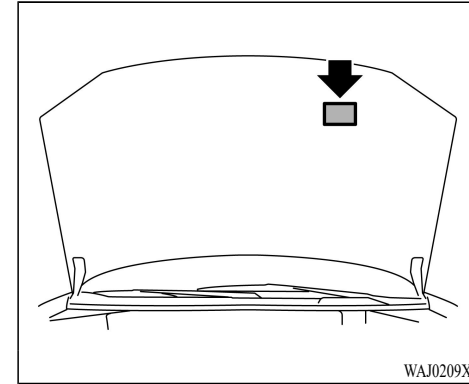

EMISSION CONTROL INFORMATION LABEL

The emission control information label is attached to the underside of the hood as shown.

TIRE AND LOADING INFORMATION PLACARD

The tire and loading information placard is located on the driver's door sill.

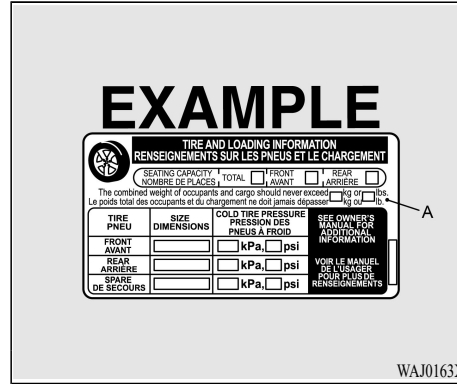
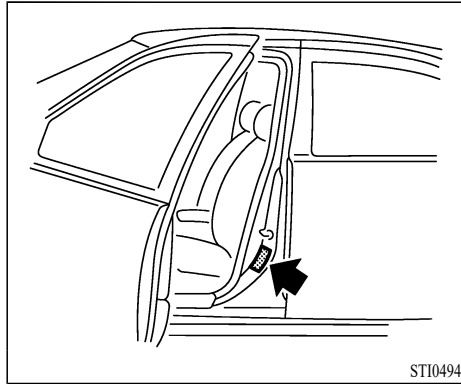

Type 2

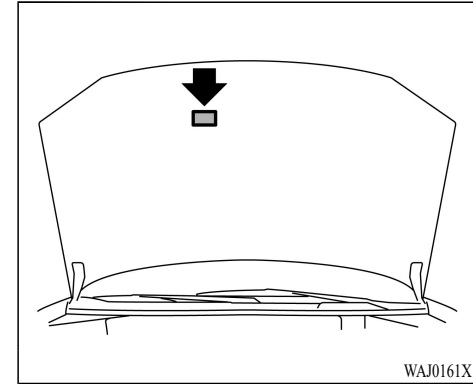



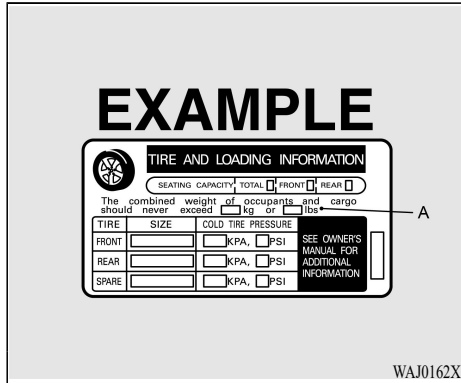

AIR CONDITIONER SPECIFICATION LABEL

The air conditioner specification label is affixed to the underside of the hood as shown.



Type 1

Air conditioner specification label symbols

Air conditioner specification label symbols:		
Symbol Name	Reference	Graphic
Caution	ISO 7000 0434	
Air Conditioning System (MAC)	ISO 2575 D01	
MAC System Lubricant Type (PAG-POE)	SAE J639 ISO 7000	
Requires Registered Technician to Service MAC System	SAE J639 ISO 7000	
Flammable Refrigerant	SAE J639 ISO 7000	

10-14 Technical and consumer information/Reporting Safety Defects

VEHICLE LOADING INFORMATION

WARNING

- It is extremely dangerous to ride in a cargo area inside the vehicle. In a collision, people riding in these areas are more likely to be seriously injured or killed.
- Do not allow people to ride in any area of your vehicle that is not equipped with seats and seat belts.
- Be sure everyone in your vehicle is in a seat and using a seat belt properly.

TERMS

It is important to familiarize yourself with the following terms before loading your vehicle:

- Vehicle maximum load on the tire: load on an individual tire that is determined by distributing to each axle its share of the maximum loaded vehicle weight and dividing by two.
- Vehicle normal load on the tire: load on an individual tire that is determined by distributing to each axle its share of the curb weight, accessory weight, and normal occupant weight and dividing by two.
- Maximum loaded vehicle weight: the sum of -
 - Curb weight;
 - Accessory weight;
 - Vehicle capacity weight; and
 - Production options weight.
- Curb weight: the weight of a motor vehicle with standard equipment including the maximum capacity of fuel, oil, and coolant.
- Accessory weight: the combined weight (in excess of those standard items which may be replaced) of automatic transaxle, power steering, power brakes, power windows, power seats, radio, and heater, to the extent that these items are available as factory- installed equipment (whether installed or not).
- Vehicle capacity weight: the rated cargo and luggage load plus 150 lb (68 kg) *times the vehicle's designated seating capacity.
- Production options weight: the combined weight of those installed regular production options weighing over 5 lb (2.3 kg) in excess of those standard items which they replace, not previously considered in curb weight or accessory weight, including heavy duty brakes, ride levelers, roof rack, heavy duty battery, and special trim.
- Normal occupant weight: 150 lbs (68 kg) *times the number of specified occupants (3 in the case of your vehicle)
- Occupant distribution: Occupant distribution within the passenger compartment (In your vehicle the distribution is 2 in front, 1 in second row seat)

- GVW (Gross Vehicle Weight) - curb weight plus the combined weight of passengers and cargo.
- GVWR (Gross Vehicle Weight Rating) - maximum total combined weight of the unloaded vehicle, passengers, luggage, hitch, trailer tongue load and any other optional equipment. This information is located on the F.M.V.S.S./C.M.V.S.S. label.
- GAWR (Gross Axle Weight Rating) - maximum weight (load) limit specified for the front or rear axle. This information is located on the F.M.V.S.S./C.M.V.S.S. label.
- GCWR (Gross Combined Weight Rating) - The maximum total weight rating of the vehicle, passengers, cargo, and trailer.
- Vehicle Capacity Weight, Load limit, Total load capacity - maximum total weight limit specified of the load (passengers and cargo) for the vehicle. This is the maximum combined weight of occupants and

cargo that can be loaded into the vehicle. If the vehicle is used to tow a trailer, the trailer tongue weight must be included as part of the cargo load. This information is located on the Tire and Loading Information placard.

- Cargo capacity - permissible weight of cargo, the subtracted weight of occupants from the load limit.

*: 150 lbs (68 kg) is the weight of one person as defined by U.S.A. and Canadian regulations.

VEHICLE LOAD CAPACITY

Do not exceed the load limit of your vehicle shown as “The combined weight of occupants and cargo” on the Tire and Loading Information placard. Do not exceed the number of occupants shown as “Seating Capacity” on the Tire and Loading Information placard.

To get “the combined weight of occupants and cargo”, add the weight of all occupants, then add the total

luggage weight. Examples are shown in the following illustration.

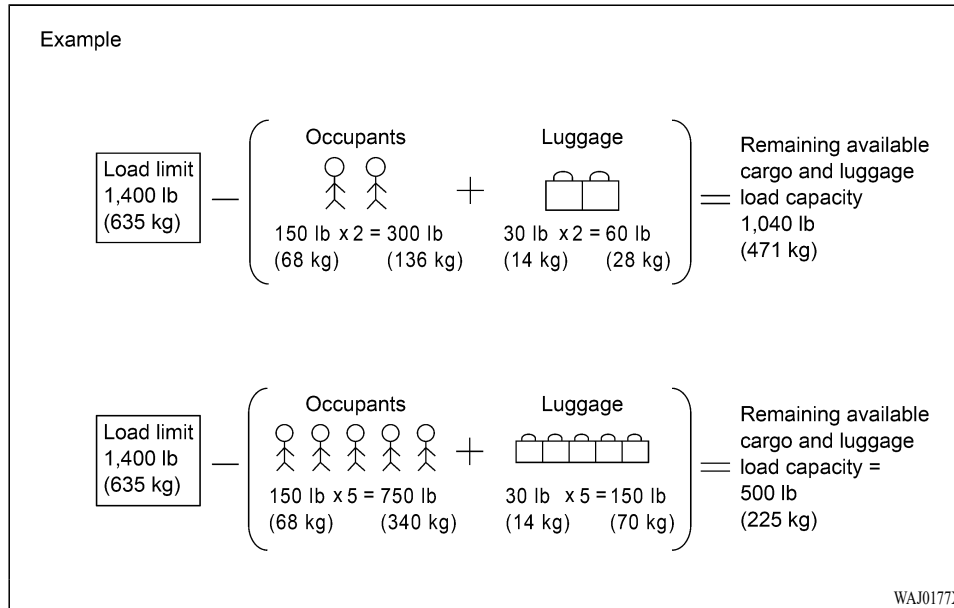

Steps for determining correct load limit

1. Locate the statement “The combined weight of occupants and cargo should never exceed XXX lb or XXX kg” on your vehicle’s

placard.

2. Determine the combined weight of the driver and passengers that will be riding in your vehicle.
3. Subtract the combined weight of the driver and passengers from XXX lb

or XXX kg.

4. The resulting figure equals the available amount of cargo and luggage load capacity. For example, if the XXX amount equals 1,400 lb. and there will be five 150 lb. passengers in your vehicle, the amount of available cargo and luggage load capacity is 650 lb. $(1,400 - 750 (5 \times 150) = 650 \text{ lb})$
5. Determine the combined weight of luggage and cargo being loaded on the vehicle. That weight may not safely exceed the available cargo and luggage load capacity calculated in Step 4.
6. If your vehicle will be towing a trailer, load from your trailer will be transferred to your vehicle. Consult this manual to determine how this reduces the available cargo and luggage load capacity of your vehicle.

Before driving a loaded vehicle, confirm that you do not exceed the Gross

Vehicle Weight Rating (GVWR) or the Gross Axle Weight Rating (GAWR) for your vehicle. (See “Measurement of weights” (P.10-19).)

Also check tires for proper inflation pressures. See the Tire and Loading Information placard.

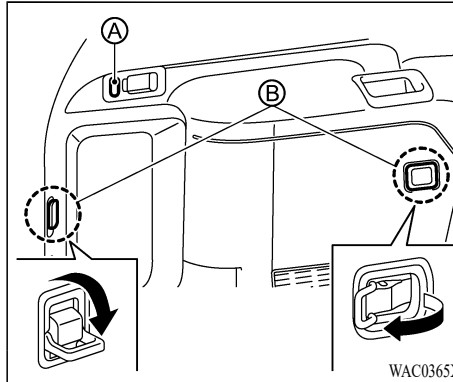

SECURING THE LOAD

There are luggage hooks A B located in the cargo area as shown. The hooks can be used to secure cargo with ropes or other types of straps.

Do not apply a total load of more than 6.6 lb (3 kg) for hook A or 44 lb (20 kg) for hook B to a single hook when securing cargo.

WARNING

- Properly secure all cargo with ropes or straps to help prevent it from sliding or shifting. Do not place cargo higher than the seatbacks. In a sudden stop or collision, unsecured cargo could cause personal

injury.

- The child restraint top tether strap may be damaged by contact with items in the cargo area. Secure any items in the cargo area. Your child could be seriously injured or killed in a collision if the top tether strap is damaged.
- Do not load your vehicle any heavier than the GVWR or the maximum front and rear GAWRs. If you do, parts of your vehicle can break, tire damage could occur, or it can change the way your vehicle handles. This could result in loss of control and cause personal injury.

LOADING TIPS

- The GVW must not exceed GVWR or GAWR as specified on the F.M. V.S.S./C.M.V.S.S. certification label.
- Do not load the front and rear axle to the GAWR. Doing so will exceed the GVWR.

WARNING

- Properly secure all cargo with ropes or straps to help prevent

it from sliding or shifting. Do not place cargo higher than the seatbacks. In a sudden stop or collision, unsecured cargo could cause personal injury.

- Do not load your vehicle any heavier than the GVWR or the maximum front and rear GAWRs. If you do, parts of your vehicle can break, tire damage could occur, or it can change the way your vehicle handles. This could result in loss of control and cause personal injury.
- Overloading not only can shorten the life of your vehicle and the tire, but can cause unsafe vehicle handling and longer braking distances. This may cause a premature tire failure, which could result in a serious accident and personal injury. Failures caused by overloading are not covered

by the vehicle's warranty.

MEASUREMENT OF WEIGHTS

Secure loose items to prevent weight shifts that could affect the balance of your vehicle. When the vehicle is loaded, drive to a scale and weigh the front and the rear wheels separately to determine axle loads. Individual axle loads should not exceed either of the Gross Axle Weight Ratings (GAWR). The total of the axle loads should not exceed the Gross Vehicle Weight Rating (GVWR). These ratings are given on the vehicle certification label. If weight ratings are exceeded, move or remove items to bring all weights below the ratings.

TOWING A TRAILER

WARNING

Overloading or improper loading of a trailer and its cargo can adversely affect vehicle handling, braking and performance and may lead to accidents.

CAUTION

- Do not tow a trailer or haul a heavy load for the first 500 miles (800 km). Your engine, axle or other parts could be damaged.
- For the first 500 miles (800 km) that you tow a trailer, do not drive over 50 MPH (80 km/h) and do not make starts at full throttle. This helps the engine and other parts of your vehicle wear in at the heavier loads.

Your new vehicle was designed to be used primarily to carry passengers and cargo. Remember that towing a trailer places additional loads on your vehicle's engine, drivetrain, steering, braking and other systems.

MAXIMUM LOAD LIMITS

Maximum trailer loads

Never allow the total trailer load to exceed the value specified in the “Towing load/specification” (P.10-22). The total trailer load equals trailer weight plus its cargo weight.

The maximum Gross Combined Weight Rating (GCWR) should not exceed the value specified in the following “Towing Load/Specification” chart.

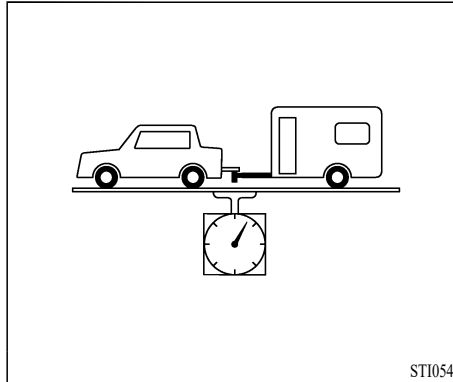

The GCWR equals the combined weight of the towing vehicle (including passengers and cargo) plus the total trailer load. Towing loads greater than these or using improper towing equipment could adversely affect vehicle handling, braking and performance.

The ability of your vehicle to tow a trailer is not only related to the maximum trailer loads, but also the places you plan to tow. Tow weights appropriate for level highway driving may have to be reduced on very steep grades or for low traction situations (for example, on slippery boat ramps).

Temperature conditions can also affect towing. For example, towing a heavy trailer in high

outside temperatures on graded roads can affect engine performance and cause overheating. The transmission high fluid temperature and engine protection mode, which helps reduce the chance of transmission and engine damage, could activate and automatically decrease engine power. Vehicle speed may decrease under high load. Plan your trip carefully to account for trailer and vehicle load, weather and road conditions.

WARNING

Overheating can result in reduced engine power and vehicle speed. The reduced speed may be lower than other traffic, which could increase the chance of a collision. Be especially careful when driving. If the vehicle cannot maintain a safe driving speed, pull to the side of the road in a safe area. Allow the engine to cool and return to normal operation. See “If your vehicle overheats” (P.6-14).

CAUTION

Vehicle damage resulting from improper towing procedures is not covered by Mitsubishi Motors warranties.

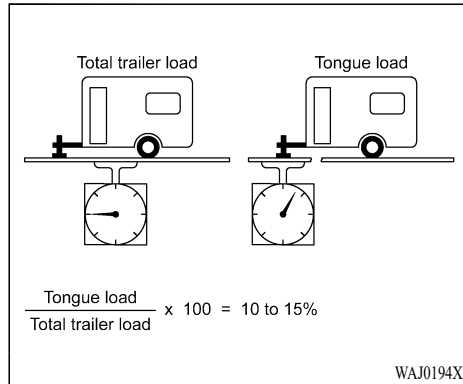

Tongue load

When using a weight carrying or a weight distributing hitch, keep the tongue load between 10 to 15% of the total trailer load or use the trailer tongue load specified by the trailer manufacturer. The tongue load must be within the maximum tongue load limits shown in the following “Towing Load/Specification” chart. If the tongue load becomes excessive, rearrange cargo to allow for proper tongue load.

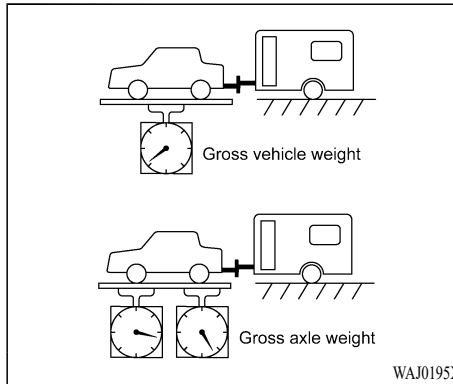

MAXIMUM GROSS VEHICLE WEIGHT (GVW)/MAXIMUM GROSS AXLE WEIGHT (GAW)

The GVW of the towing vehicle must not exceed the Gross Vehicle Weight Rating (GVWR) shown on the F.M.V.S.S./C.M.V.S.S. certification label. The GVW equals the combined weight of the unloaded vehicle, passengers, luggage, hitch, trailer tongue load and any other optional equipment. In addition, front or rear GAW must not exceed the Gross Axle Weight Rating (GAWR) shown on the F.M.V.S.S./C.M.V.S.S. certification label.

Towing capacities are calculated assuming a base vehicle with driver and any options

required to achieve the rating. Additional passengers, cargo and/or optional equipment, such as the trailer hitch, will add weight to the vehicle and reduce your vehicle’s maximum towing capacity and trailer tongue load.

The vehicle and trailer need to be weighed to confirm the vehicle is within the GVWR, Front GAWR, Rear GAWR, Gross Combined Weight Rating (GCWR) and Towing capacity.

All vehicle and trailer weights can be measured using platform type scales commonly found at truck stops, highway weigh stations, building supply centers or salvage yards.

To determine the available payload capacity for tongue/king pin load, use the following procedure.

1. Locate the GVWR on the F.M.V.S.S./C.M.V.S.S. certification label.
2. Weigh your vehicle on the scale with all of the passengers and cargo that are normally in the vehicle when towing a trailer.
3. Subtract the actual vehicle weight from the GVWR. The remaining amount is the available maximum tongue/king pin load.

To determine the available towing capacity, use the following procedure.

1. Find the GCWR for your vehicle on the “Towing Load/Specification” chart found later in this section.

2. Subtract the actual vehicle weight from the GCWR. The remaining amount is the available maximum towing capacity.

To determine the Gross Trailer Weight, weigh your trailer on a scale with all equipment and cargo, that are normally in the trailer when it is towed. Make sure the Gross trailer weight is not more than the Gross Trailer Weight Rating shown on the trailer and is not more than the calculated available maximum towing capacity.

Also weigh the front and rear axles on the scale to make sure the Front Gross Axle Weight and Rear Gross Axle Weight are not more than Front Gross Axle Weight and Rear Gross Axle Weight on the F.M.V.S.S./C.M.V.S.S. certification label. The cargo in the trailer and vehicle may need to be moved or removed to meet the specified ratings.

Example:

- Gross Vehicle Weight (GVW) as weighed on a scale - including passengers, cargo and hitch - 6,350 lb. (2,880 kg).
- Gross Vehicle Weight Rating (GVWR) from F.M.V.S.S./C.M.V.S.S. certification label - 7,250 lb. (3,289 kg).
- Gross Combined Weight Rating (GCWR) from “Towing Load/Specification” chart - 15,100 lb. (4,128 kg).

- Maximum Trailer towing capacity from “Towing Load/Specification” chart - 9,100 lb (4,128 kg).

7,250 lb. (3,289 kg)	GVWR
- 6,350lb. (2,880 kg)	GVW
= 900 lb. (409 kg)	Available for tongue weight

15,100 lb. (6,849 kg)	GCWR
- 6,350 lb. (2,880 kg)	GVW
= 9,123 lb. (4,138 kg)	Capacity available for towing

900 lb. (409 kg) /	Available tongue weight
8,750 lb. (3,969 kg)	Available capacity
= 10 % tongue weight	

The available towing capacity may be less than the maximum towing capacity due to the passenger and cargo load in the vehicle.

Remember to keep trailer tongue weight between 10 - 15% of the trailer weight or within the trailer tongue load specification recommended by the trailer manufacturer. If the tongue load becomes excessive, rearrange the cargo to obtain the proper tongue load. Do

not exceed the maximum tongue weight specification shown in the “Towing load/specification” chart even if the calculated available tongue weight is greater than 15%. If the calculated tongue weight is less than 10%, reduce the total trailer weight to match the available tongue weight.

Always verify that available capacities are within the required ratings.

TOWING LOAD/SPECIFICATION

WARNING

The towing capacities provided in this manual are for general reference only. The safe towing capacity of your vehicle is affected by dealer and factory installed options and passenger and cargo loads. You must weigh the vehicle and trailer as described in this manual to determine the actual vehicle towing capacity. Do not exceed the published maximum towing capacity, or the GCWR or the GVWR shown on the F.M.V.S.S./C.M.V.S.S. certification label. Doing so can result in an accident causing serious personal injury or property damage.

Towing load/specification chart		
Axle Type	Front-Wheel Drive (FWD)	All-Wheel Control (AWC)
Maximum Towing Capacity*1	2,000 lbs (907 kg)	
Maximum Tongue Load	200 lbs (91 kg)	
Maximum Gross Combined Weight Rating	6,306 lbs (2,860 kg)	

- 1: The towing capacity values are calculated assuming a base vehicle with driver and one passenger and any options required to achieve the rating. Additional passengers, cargo and/or optional equipment will add weight to the vehicle and reduce your vehicle's maximum towing capacity.

TOWING SAFETY

Trailer hitch

Choose a proper hitch for your vehicle and trailer. Make sure the trailer hitch is securely attached to the vehicle to help avoid personal injury or property damage due to sway caused by crosswinds, rough road surfaces or passing trucks.



WARNING

Trailer hitch components have specific weight ratings. Your vehicle may be capable of towing a trailer heavier than the weight rating of the hitch components. Never exceed the weight rating of the hitch components. Doing so can cause serious personal injury or property damage.

Hitch ball

Choose a hitch ball of the proper size and weight rating for your trailer:

- The required hitch ball size is stamped on most trailer couplers. Most hitch balls also have the size printed on top of the ball.
- Choose the proper class hitch ball based on the trailer weight.

- The diameter of the threaded shank of the hitch ball must be matched to the ball mount hole diameter. The hitch ball shank should be no more than 1/16" smaller than the hole in the ball mount.
- The threaded shank of the hitch ball must be long enough to be properly secured to the ball mount. There should be at least 2 threads showing beyond the lock washer and nut.

Ball mount

The hitch ball is attached to the ball mount and the ball mount is inserted into the hitch receiver. Choose a proper class ball mount based on the trailer weight. Additionally, the ball mount should be chosen to keep the trailer tongue level with the ground.

Weight carrying hitches

A weight carrying or "dead weight" ball mount is one that is designed to carry the whole amount of tongue weight and gross weight directly on the ball mount and on the receiver.

Weight distribution hitch

This type of hitch is also called a "load-leveling" or "equalizing" hitch. A set of bars attach to the ball mount and to the trailer to distribute the tongue weight (hitch weight) of your trailer. Many vehicles cannot carry the full tongue weight of a given trailer, and need some of the tongue weight transferred through the frame and pushing down on the front wheels. This gives stability to the tow vehicle.

A weight-distributing hitch system (Class IV) is recommended if you plan to tow trailers with a maximum weight over 5,000 lb (2,267 kg). Check with the trailer and towing equipment manufacturers to determine if they recommend the use of a weight-distributing hitch system.

NOTE:

A weight-distributing hitch system may affect the operation of trailer surge brakes. If you are considering use of a weight-distributing hitch system with a surge brake-equipped trailer, check with the surge brake, hitch or trailer manufacturer to determine if and how this can be done.

Follow the instructions provided by the manufacturer for installing and using the weight-distributing hitch system.

General set-up instructions are as follows:

1. Park unloaded vehicle on a level surface. With the ignition switch in the ON position and the doors closed, allow the vehicle to stand for several minutes so that it can level.
2. Measure the height of a reference point on the front and rear bumpers at the center of the vehicle.
3. Attach the trailer to the vehicle and adjust the hitch equalizers so that the front bumper height is within 0 - .5 inches (0 - 13 mm) of the reference height measured in step 2. The rear bumper should be no higher than the reference height measured in step 2.

WARNING

Properly adjust the weight distributing hitch so the rear of the bumper is no higher than the measured reference height when the trailer is attached. If the rear bumper is higher than the measured reference height when loaded, the vehicle may handle unpredictably which could cause a loss of vehicle control and cause serious personal injury or property damage.

Sway control device

Sudden maneuvers, wind gusts and buffeting caused by other vehicles can affect trailer handling. Sway control devices may be used to help control these affects. If you choose to use one, contact a reputable trailer hitch supplier to make sure the sway control device will work with the vehicle, hitch, trailer and the trailer's brake system. Follow the instructions provided by the manufacturer for installing and using the sway control device.

Class I hitch

Class I trailer hitch equipment (receiver, ball mount and hitch ball) can be used to tow trailers of a maximum weight of 2,000 lb (907 kg).

Class II hitch

Class II trailer hitch equipment (receiver, ball mount and hitch ball) can be used to tow trailers of a maximum weight of 3,500 lb (1,588 kg).

Class III hitch

Class III trailer hitch equipment (receiver, ball mount and hitch ball) can be used to tow trailers of a maximum weight of 5,000 lb (2,267 kg).

Class IV hitch

Class IV trailer hitch equipment (receiver, ball mount and hitch ball) can be used to tow trailers of a maximum weight of 10,000 lb (4,545 kg). A weight distributing hitch should be used to tow trailers that weigh over 5,000 lb (2,267 kg).

Your vehicle may be equipped with Class IV trailer hitch equipment that has a 10,000 lb (4,545 kg) maximum weight rating, but your vehicle is only capable of towing the maximum trailer weights shown in the "Towing Load/Specification" chart earlier in this section.

CAUTION

- Do not use axle-mounted hitches.
- Do not modify the vehicle exhaust system, brake system, etc.

Tire pressures

- When towing a trailer, inflate the vehicle tires to the recommended cold tire pressure indicated on the Tire and Loading Information placard.
- Trailer tire condition, size, load rating and proper inflation pressure

should be in accordance with the trailer and tire manufacturers' specifications.

Safety chains

Always use a suitable chain between your vehicle and the trailer. The safety chains should be crossed and should be attached to the hitch, not to the vehicle bumper or axle. Be sure to leave enough slack in the chains to permit turning corners.

Trailer lights (if so equipped)

CAUTION

- When splicing into the vehicle electrical system, a commercially available power-type module/converter must be used to provide power for all trailer lighting. This unit uses the vehicle battery as a direct power source for all trailer lights while using the vehicle tail light, stoplight and turn signal circuits as a signal source. The module/converter must draw no more than 15 milliamps from the stop and tail lamp circuits. Using a module/converter that exceeds these power requirements may damage the vehicle's electrical system. See a reputable trailer retailer to obtain the proper equipment and to have it

installed.

Trailer lights should comply with federal and/or local regulations. For assistance in hooking up trailer lights, contact an authorized Mitsubishi Motors dealer or reputable trailer retailer.

Trailer brakes

When towing a trailer load of 3,500 lb (1,587 kg) or more, trailers with a brake system MUST be used. However, most states require a separate braking system on trailers with a loaded weight above a specific amount. Make sure the trailer meets the local regulations and the regulations where you plan to tow.

Several types of braking systems are available.

Surge Brakes - The surge brake actuator is mounted on the trailer tongue with a hydraulic line running to each trailer wheel. Surge brakes are activated by the trailer pushing against the hitch ball when the tow vehicle is braking. Hydraulic surge brakes are common on rental trailers and some boat trailers. In this type of system, there is no hydraulic or electric connection for brake operation between the tow vehicle and the trailer.

Electric Trailer Brakes - Electric braking systems are activated by an electronic signal sent from a trailer brake controller (special brake sensing module).

Have a professional supplier of towing equipment make sure the trailer brakes are properly installed and demonstrate proper brake function testing.



WARNING

Never connect a trailer brake system directly to the vehicle brake system.

Pre-towing tips

- Be certain your vehicle maintains a level position when a loaded or unloaded trailer is hitched. Do not drive the vehicle if it has an abnormal nose-up or nose-down condition; check for improper tongue load, overload, worn suspension or other possible causes of either condition.
- Always secure items in the trailer to prevent load shift while driving.
- Keep the cargo load as low as possible in the trailer to keep the trailer center of gravity low.
- Load the trailer so approximately 60% of the trailer load is in the front half and 40% is in the back half. Also make sure the load is balanced side to side.
- Check your hitch, trailer tire pressure, vehicle tire pressure, trailer light operation,

and trailer wheel lug nuts every time you attach a trailer to the vehicle.

- Be certain your rearview mirrors conform to all federal, state or local regulations. If not, install any mirrors required for towing before driving the vehicle.
- Determine the overall height of the vehicle and trailer so the required clearance is known.

Trailer towing tips

In order to gain skill and an understanding of the vehicle's behavior, you should practice turning, stopping and backing up in an area which is free from traffic. Steering stability, and braking performance will be somewhat different than under normal driving conditions.

- Always secure items in the trailer to prevent load shift while driving.
- Lock the trailer hitch coupler with a pin or lock to prevent the coupler from inadvertently becoming unlatched.
- Avoid abrupt starts, acceleration or stops.
- Avoid sharp turns or lane changes.
- Always drive your vehicle at a moderate speed. Some states or provinces have specific speed limits for vehicles that are towing trailers. Obey the local speed limits.

- When backing up, hold the bottom of the steering wheel with one hand. Move your hand in the direction in which you want the trailer to go. Make small corrections and back up slowly. If possible, have someone guide you when you are backing up.

Always block the wheels on both vehicle and trailer when parking. Parking on a slope is not recommended; however, if you must do so:

CAUTION

If you push the park button to shift to the P (Park) position before blocking the wheels and applying the parking brake, transmission damage could occur.

1. Apply and hold the brake pedal.
2. Have someone place blocks on the downhill side of the vehicle and trailer wheels.
3. After the wheel blocks are in place, slowly release the brake pedal until the blocks absorb the vehicle load.
4. Apply the parking brake.
5. Push the park button to shift to the P (Park) position.
6. Turn off the engine.

To drive away:

1. Apply and hold the brake pedal.
 2. Start the engine.
 3. Shift the transmission into gear.
 4. Release the parking brake.
 5. Drive slowly until the vehicle and trailer are clear from the blocks.
 6. Apply and hold the brake pedal.
 7. Have someone retrieve and store the blocks.
- While going downhill, the weight of the trailer pushing on the tow vehicle may decrease overall stability. Therefore, to maintain adequate control, reduce your speed and shift to a lower gear. Avoid long or repeated use of the brakes when descending a hill, as this reduces their effectiveness and could cause overheating. Shifting to a lower gear instead provides “engine braking” and reduces the need to brake as frequently.
 - If the engine coolant temperature rises to a high temperature, see “If your vehicle overheats” (P.6-14).
 - Trailer towing requires more fuel than normal circumstances.
 - Avoid towing a trailer for your vehicle’s first 500 miles (800 km).
 - For the first 500 miles (800 km) that you do tow, do not drive over 50 MPH (80 km/h).

- Have your vehicle serviced more often than at intervals specified in the recommended maintenance schedule.
- When making a turn, your trailer wheels will be closer to the inside of the turn than your vehicle wheels. To compensate for this, make a larger than normal turning radius during the turn.
- Crosswinds and rough roads will adversely affect vehicle/trailer handling, possibly causing vehicle sway. When being passed by larger vehicles, be prepared for possible changes in crosswinds that could affect vehicle handling.

Do the following if the trailer begins to sway:

1. Take your foot off the accelerator pedal to allow the vehicle to coast and steer as straight ahead as the road conditions allow. This combination will help stabilize the vehicle.
 - Do not correct trailer sway by steering or applying the brakes.
2. When the trailer sway stops, gently apply the brakes and pull to the side of the road in a safe area.
3. Try to rearrange the trailer load so it is balanced as described earlier in this section.
 - Be careful when passing other vehicles. Passing while towing a trailer requires

considerably more distance than normal passing. Remember the length of the trailer must also pass the other vehicle before you can safely change lanes.

- Downshift the transmission to a lower gear for engine braking when driving down steep or long hills. This will help slow the vehicle without applying the brakes.
- Avoid holding the brake pedal down too long or too frequently. This could cause the brakes to overheat, resulting in reduced braking efficiency.
- Increase your following distance to allow for greater stopping distances while towing a trailer. Anticipate stops and brake gradually.
- Mitsubishi Motors recommends that the cruise control not be used while towing a trailer.
- While towing a trailer, do not use the following systems (if so equipped):
 - the Lane Departure Warning (LDW) system
 - the Lane Departure Prevention (LDP) system
 - the Blind Spot Warning (BSW) system
 - the Rear Cross Traffic Alert (RCTA) system

- the Adaptive Cruise Control System (ACC) system
- the MI-PILOT Assist system
- the Forward Collision Mitigation System (FCM)
- the Predictive Forward Collision Warning (PFCW) system
- the Rear Automatic Emergency Braking (Rear AEB) system
- Some states or provinces have specific regulations and speed limits for vehicles that are towing trailers. Obey the local speed limits.
- Check your hitch, trailer wiring harness connections, and trailer wheel lug nuts after 50 miles (80 km) of travel and at every break.
- When launching a boat, do not allow the water level to go over the exhaust tail pipe or rear bumper.
- Make sure you disconnect the trailer lights (if so equipped) before backing the trailer into the water or the trailer lights may burn out.

When towing a trailer, the transmission fluid should be changed more frequently.

Trailer Stability Assist (TSA)

The Trailer Stability Assist (TSA) system helps safety running while towing a trailer by controlling the braking force of each wheel and engine power in order to stabilize the motion when detecting the continuous sway of the vehicle caused by a trailer. When the TSA system operates the brakes, the brake light turns on. About the towing of the trailer, refer to “Towing a trailer” (P.10-19).

CAUTION

- **Do not over-rely on TSA system**

Due to the slippery road surface, heavy side wind, inappropriate weight and positioning of luggage, and/or driving at high speed, TSA system may fail to secure the stability.

Always drive appropriately in accordance with the condition of traffic, road surface condition, weather, and the weight and positioning of luggage.

- **The TSA system does not operate in case as follows**
 - **When sudden braking and braking while driving downhill cause an abrupt motion of the vehicle which makes the vehicle and the**

trailer form a dogleg shape.

- When a sideslip occurs by sudden steering

NOTE:

- When TSA system operates, the vehicle body may vibrate and the operating sounds from the engine compartment may be heard. These motions indicate normal operation of the system, not abnormal operation.
- TSA system operates when the vehicle speed is approximately 37 MPH (60 km/h) or higher.
- When TSA system operates, the Active stability control (ASC) indicator light blinks on and off.
- When ASC does not work, TSA system does not operate.

FLAT TOWING

FLAT TOWING FOR ALL-WHEEL CONTROL VEHICLE (if so equipped)

Towing your vehicle with all four wheels on the ground is sometimes called flat towing. This method is sometimes used when towing a vehicle behind a recreational vehicle, such as a motor home.



CAUTION

- Failure to follow these guidelines can result in severe transmission damage.
- Never flat tow your All-Wheel Drive (AWC) vehicle.
- DO NOT tow your All-Wheel Drive (AWC) vehicle with any wheels on the ground. Doing so may cause serious and expensive damage to the powertrain.
- For emergency towing procedures refer to “Towing recommended by Mitsubishi Motors” (P.6-17).

FLAT TOWING FOR FRONT-WHEEL DRIVE VEHICLE (if so equipped)

Towing your vehicle with all four wheels on the ground is sometimes called flat towing. This method is sometimes used when towing a vehicle behind a recreational vehicle, such as a motor home.



CAUTION

- Failure to follow these guidelines can result in severe transmission damage.
- Whenever flat towing your vehicle, always tow forward, never backward.
- Never tow your front wheel drive vehicle with the front tires on the ground. Doing so may cause serious and expensive damage to the powertrain.
- DO NOT tow your front wheel drive Continuously Variable Transmission (CVT) vehicle with all four wheels on the ground (flat towing). Doing so WILL DAMAGE internal transmission parts due to lack of transmission lubrication.
- For emergency towing procedures refer to “Towing recommended by Mitsubishi Motors” (P.6-17).

UNIFORM TIRE QUALITY GRADING

Continuously Variable Transmission (CVT)

To tow a vehicle equipped with a CVT, an appropriate vehicle dolly **MUST** be placed under the towed vehicle's drive wheels. **Always** follow the dolly manufacturer's recommendations when using their product.

DOT (Department Of Transportation) Quality Grades: All passenger car tires must conform to federal safety requirements in addition to these grades.

Quality grades can be found where applicable on the tire sidewall between tread shoulder and maximum section width. For example:

Treadwear 200 Traction AA Temperature A TREADWEAR

The treadwear grade is a comparative rating based on the wear rate of the tire when tested under controlled conditions on a specified government test course. For example, a tire graded 150 would wear one and one-half

(1 1/2) times as well on the government course as a tire graded 100. The relative performance of tires depends upon the actual conditions of their use, however, and may depart significantly from the norm due to variations in driving habits, service practices and differences in road characteristics and climate.

TRACTION AA, A, B AND C

The traction grades, from highest to lowest, are AA, A, B and C. Those grades represent the tire's ability to stop on wet pavement as measured under controlled conditions on specified government test surfaces of asphalt and concrete. A tire marked C may have poor traction performance.

WARNING

The traction grade assigned to this tire is based on straight-ahead braking traction tests, and does not include acceleration, cornering, hydroplaning, or peak traction characteristics.

TEMPERATURE A, B AND C

The temperature grades are A (the highest), B, and C, representing the tire's resistance to the generation of heat and its ability to dissipate heat when tested under controlled conditions on a specified indoor laboratory test wheel. Sustained high temperature can cause the material of the tire to degenerate and reduce tire life, and excessive temperature can lead to sudden tire failure. The grade C corresponds to a level of performance which all passenger car tires must meet under the Federal Motor Vehicle Safety Standard No. 109. Grades B and A represent higher levels of performance on the laboratory test wheel than the minimum required by law.

WARNING

The temperature grade for this tire is established for a tire that is properly inflated and not overloaded. Excessive speed, underinfla-

tion, or excessive loading, either separately or in combination, can cause heat build-up and possible tire failure.

EMISSION CONTROL SYSTEM WARRANTY

Your vehicle is covered by the following emission warranties.

- Emission Defects Warranty
- Emissions Performance Warranty

Details of these warranties may be found with other vehicle warranties in your Warranty and Maintenance Manual which comes with your vehicle.

REPORTING SAFETY DEFECTS

If you believe that your vehicle has a defect which could cause a crash or could cause injury or death, you should immediately inform the National Highway Traffic Safety Administration (NHTSA) in addition to notifying Mitsubishi Motors Corporation.

If NHTSA receives similar complaints, it may open an investigation, and if it finds that a safety defect exists in a group of vehicles, it may order a recall and remedy campaign. However, NHTSA cannot become involved in individual problems between you, your dealer, or Mitsubishi Motors Corporation.

To contact NHTSA, you may call the Vehicle Safety Hotline toll-free at 1-888-327-4236 (TTY: 1-800-424-9153); go to <http://www.safercar.gov>; or write to:

NHTSA Headquarters
1200 New Jersey Avenue, SE
West Building

Washington, DC 20590

You can also obtain other information about motor vehicle safety from <http://www.safercar.gov>.

For vehicles sold in U.S.A.

To contact Mitsubishi Motors North America, Inc. call 1-888-648-7820 or write to:

Mitsubishi Motors North America, Inc.

**Customer Relations Department
P.O. Box 689040
Franklin, TN 37068**

For vehicles sold in Canada

If you live in Canada, and you believe that your vehicle has a safety defect, you should immediately notify Transport Canada.

To contact Transport Canada's Defect Investigations and Recalls Division, you may call the toll-free number: 1-

800-333-0510.

**Transport Canada - ASFAD
330 Sparks Street
Ottawa, ON
K1A 0N5**

You can also obtain additional information concerning motor vehicle safety from

<http://www.tc.gc.ca/recalls> (English)

or

<http://www.tc.gc.ca/rappels> (French).

In addition to notifying Mitsubishi Motor Sales of Canada, Inc.

To contact Mitsubishi Motor Sales of Canada, Inc. call 1-888-576-4878 or write to:

**Mitsubishi Motor Sales of Canada, Inc.
Customer Relations Department
P.O. Box 41009
4141 Dixie Road
Mississauga, ON L4W 5C9**

For Puerto Rico

To contact Mitsubishi Motor Sales of Caribbean, Inc. call 1-787-251-8715 or write to:

Mitsubishi Motor Sales of Caribbean, Inc.

Customer Service Department
P.O. Box 192216
SAN JUAN PR 00919-2216

For Guam

To contact Triple J Enterprises Inc. call (671)649-3673 or write to:

Triple J Enterprises, Inc.

P.O. Box 6066
TAMUNING
GUAM 96931

For Saipan

To contact Triple J Motors call (670) 234-7133 or write to:

Triple J Motors
P.O. Box 500487

READINESS FOR INSPECTION/ MAINTENANCE (I/M) TEST

SAIPAN, MP96950-0487

For American Samoa

To contact Pacific Marketing Inc. call
684(699)9140 or write to:

Pacific Marketing, Inc.

P.O. Box 698

PAGO PAGO,

AMERICAN SAMOA AS, 96799

WARNING

A vehicle equipped with All-Wheel Control (AWC) should never be tested using a two wheel dynamometer (such as the dynamometers used by some states for emissions testing), or similar equipment. Make sure you inform test facility personnel that your vehicle is equipped with AWC before it is placed on a dynamometer. Using the wrong test equipment may result in transmission damage or unexpected vehicle movement which could result in serious vehicle damage or personal injury.

Light (MIL) comes on steady for 20 seconds and then blinks for 10 seconds, the I/M test condition is “not ready”. If the MIL does not blink after 20 seconds, the I/M test condition is “ready”.

It is recommended you visit an authorized Mitsubishi Motors dealer to set “ready condition” or to prepare the vehicle for testing.

Due to legal requirements in some states/areas or provinces, your vehicle may be required to be in what is called the “ready condition” for an Inspection/Maintenance (I/M) test of the emission control system.

The vehicle is set to the “ready condition” when it is driven through certain driving patterns. Usually, the “ready condition” can be obtained by ordinary usage of the vehicle.

If a powertrain system component is repaired or the battery is disconnected, the vehicle may be reset to a “not ready condition”. Before taking the I/M test, check the vehicle’s inspection/maintenance test readiness condition. Place the ignition switch in the ON position without starting the engine. If the Malfunction Indicator

EVENT DATA RECORDERS (EDR)

This vehicle is equipped with an event data recorder (EDR). The main purpose of an EDR is to record, in certain crash or near crashlike situations, such as an air bag deployment or hitting a road obstacle, data that will assist in understanding how a vehicle's systems performed. The EDR is designed to record data related to vehicle dynamics and safety systems for a short period of time, typically 30 seconds or less. The EDR in this vehicle is designed to record such data as:

- How various systems in your vehicle were operating;
- Whether or not the driver and passenger safety belts were buckled/fastened;
- How far (if at all) the driver was depressing the accelerator and/or brake pedal; and,
- How fast the vehicle was traveling.

These data can help provide a better understanding of the circumstances in which crashes and injuries occur.

NOTE: EDR data are recorded by your vehicle only if a nontrivial crash situation occurs; no data are recorded by the EDR under normal driving conditions and no personal data (e.g. name, gender, age and crash location) are recorded. However, other parties, such as law enforcement, could combine the EDR data with the type of personally identifying data routinely acquired during a crash investigation.

To read data recorded by an EDR, special equipment is required, and access to the vehicle or the EDR is needed. In addition to the vehicle manufacturer, other parties, such as law enforcement, that have the special equipment, can read the information if they have access to the vehicle or the EDR.

ADDITIONAL DATA RECORDING

If your vehicle is equipped with the optional MI-PILOT Assist or other driver assistance features, it will also be equipped with supplemental data recording function intended to assist in understanding how MI-PILOT Assist or other driver assistance features performs in certain nontrivial crash or near-crash scenarios. Specifically, supplemental recording is designed to capture the following:

- Driver operational status of the accelerator, brakes, steering, etc.
- Detection status of a vehicle ahead and lane markers
- Vehicle information including distance to vehicle ahead and lateral position
- Information on the operation of the MI-PILOT Assist and other driver assistance features
- MI-PILOT Assist (or other driver assistance features) malfunction diagnosis information

- External images from the multi-sensing front camera (Available only when the SRS airbag or FCM system is activated)

The MI-PILOT Assist and other driver assistance features do not record conversations, sounds or images of the inside of the vehicle.

To read this supplemental data, special equipment is required and access to the vehicle or the recording unit is needed. This supplemental data will only be accessed with the consent of the vehicle owner or lessee or as otherwise required or permitted by law. If downloaded, Mitsubishi Motors and third parties entrusted by Mitsubishi Motors may use the data recorded for the purpose of improving Mitsubishi Motors's vehicle safety performance.

Mitsubishi Motors and third parties entrusted by Mitsubishi Motors will not disclose/provide the recorded data to a third party except:

- With the consent of the vehicle owner or with the consent of the lessee
- In response to an official request from law enforcement, court order, governmental agency, or other legally enforceable request
- For research purposes after the data is modified such that it is no longer tied to a specific vehicle or vehicle owner (anonymized)

11 Index

Number	
3-zone automatic climate control	4-31
4WD	
S-AWC (Super-All Wheel Control)	5-153
A	
ABS (Anti-lock Braking System)	5-157
Active Blind Spot Assist (ABSA)	5-51
Active Ride Control	5-161
Active Yaw Control (AYC)	5-160
Adaptive Cruise Control System (ACC)	5-71
Adaptive Cruise Control System (ACC) (with Stop & Go)	5-103
Advanced Airbag System	1-53
Air cleaner housing filter	8-14
Air conditioner	
Air conditioner operation	4-28
Air conditioner service	4-33
Air conditioner specification label ...	10-13
Air conditioning system refrigerant and lubricant recommendations	4-33, 10-6
Airbag system	
Advanced Airbag System	1-53
Driver and front passenger SRS knee airbag	1-62

Front and second row seat-mounted side SRS airbag system	1-63
Front passenger airbag and status light	1-55
Front seat-mounted center SRS airbag system	1-63
Side curtain SRS airbag system	1-63
Airbag warning labels	1-70
Alarm, How to stop alarm (see Anti-theft alarm system)	2-47
Alcohol, drugs and driving	5-11
Antenna	4-34
Anti-lock Braking System (ABS)	5-157
Anti-lock braking system (ABS) warning light	2-16
Anti-theft engine immobilizer	2-47
Appearance care	
Exterior appearance care	7-2
Interior appearance care	7-4
Armrest	1-9
Audible reminders	2-20
Audio	4-2
Auto Headlight system	2-54
Automatic	
Door locks	3-6
Automatic High Beam (AHB)	2-56
Average speed	2-41
Avoiding collision and rollover	5-9

AWC	
S-AWC (Super-All Wheel Control)	5-153

B	
Battery	8-11
Battery replacement, F.A.S.T.-key	8-20
Battery saver system	2-58
Battery specifications	10-10
Variable voltage control system	8-12
Before starting the engine	5-16
Blind Spot Warning (BSW)	5-43
Bluetooth® Hands-Free Phone System ...	4-2
Booster seats	1-43
Brake	
Anti-lock Braking System (ABS)	5-157
Brake fluid	8-9
Brake system	5-156
Electric parking brake warning light ...	2-17
Parking brake	5-23
Warning light	2-13
Brake Auto Hold	5-25
Break-in schedule	5-151
Brightness control	
Instrument panel	2-11
Bulb check/instrument panel	2-13
Bulb replacement	8-22

C

Capacities and recommended fluids/lubricants	10-2
Car phone or CB radio	4-34
Card holder	2-71
Catalytic converter, Three way catalyst ...	5-5
Chassis control	5-160
Child restraints	1-27
Booster seats	1-43
LATCH system	1-29
Precautions on child restraints	1-27
Child safety	1-24
Child safety rear door lock	3-6
Chimes	
Front seat belt warning light and chime	2-15
Seat belt warning light and chime	1-19
Chimes, Audible reminders	2-20
Circuit breaker, Fusible link	8-17
Cleaning exterior and interior	7-2, 7-4
Clock	2-43
Coat hook	2-72
Cockpit	2-3
Cold weather driving	5-173
Console box	2-70
Continuously Variable Transmission (CVT) fluid	8-9
Continuously Variable Transmission (CVT) position indicator	2-11

11-2

Conventional (fixed speed) cruise control mode (with MI-PILOT Assist)	5-122
Coolant	
Capacities and recommended fluids/lubricants	10-2
Changing engine coolant	8-5
Checking engine coolant level	8-5
Corrosion protection	7-6
Cover	
Tonneau cover	2-73
Cruise control	5-69
Adaptive Cruise Control System (ACC)	5-71
Adaptive Cruise Control System (ACC) (with Stop & Go)	5-103
Conventional (fixed speed) cruise control mode	5-122
Cruise control (with MI-PILOT Assist) (See Conventional (fixed speed) cruise control mode)	5-122
Fixed speed cruise control (on ACC system)	5-87
Cup holders	2-68
CVT, Driving with CVT (Continuously Variable Transmission)	5-17

D

Daytime Running Lights (DRL) system	2-58
Defroster switch, Electric rear window and door mirror defroster switch	2-52

Dimensions and weights	10-9
Display	
Head Up Display (HUD)	2-43
Multi-information display	2-21
Dome lights	2-81
Door mirrors	3-34
Drive belt	8-13
Drive Computer	2-41
Drive Mode Selector	5-28
Driver and front passenger SRS knee airbag	1-62
Driver Attention Alert (DAA)	5-143
Driver Attention Alert (DAA) system limitations	5-145
Driver memory settings	3-37
Driving	
Cold weather driving	5-173
Driving with CVT (Continuously Variable Transmission)	5-17
On-pavement and off-road driving ...	5-10
Precautions when starting and driving	5-5
Safety precautions	5-11
Dual-zone automatic climate control	4-29

E

ECO mode	5-29
Economy, Fuel	5-153
Electric power steering	5-156
Electric power steering warning light	2-16

Electric rear window and door mirror defroster switch 2-52

Electric shift control system warning light 2-14

Emergency call system (e-CALL) 2-67

Emergency key (F.A.S.T.-key) 3-3

Emission control information label 10-12

Emission control system warranty 10-31

Engine

- Before starting the engine 5-16
- Break-in schedule 5-151
- Capacities and recommended fluids/lubricants 10-2
- Changing engine coolant 8-5
- Changing engine oil and filter 8-6
- Checking engine coolant level 8-5
- Checking engine oil level 8-6
- Coolant temperature gauge 2-9
- Emergency engine shut off 5-15, 6-2
- Engine compartment check locations ... 8-3
- Engine cooling system 8-4
- Engine oil 8-6
- Engine oil and oil filter recommendation 10-5
- Engine oil viscosity 10-5
- Engine serial number 10-12
- Engine specifications 10-7
- Engine start operation indicator 2-33
- If your vehicle overheats 6-14
- Starting the engine 5-16

Event Data Recorders (EDR) 10-34

Exhaust gas (carbon monoxide) 5-5

F

F.A.S.T.-key 3-7

- Key operating range 3-9
- Key operation 3-10
- Remote keyless operation 3-15

F.A.S.T.-key button operation light 3-17

F.M.V.S.S./C.M.V.S.S. certification label 10-12

Filter

- Air cleaner housing filter 8-14
- Changing engine oil and filter 8-6

Flashers (See hazard warning flasher switch) 6-2

Flat tire 6-3

Flat towing 10-29

Floor mat cleaning 7-4

Fluid

- Brake fluid 8-9
- Capacities and recommended fluids/lubricants 10-2
- Continuously Variable Transmission (CVT) fluid 8-9
- Engine coolant 8-4
- Engine oil 8-6
- Window washer fluid 8-10

Fog light switch 2-59

Forward Collision Mitigation System (FCM) 5-126

Forward Collision Mitigation System (FCM) OFF warning light 2-16

Free-hand Advanced Security Transmitter (F.A.S.T.-key) 3-7

Front manual seat adjustment 1-3

Front passenger airbag and status light 1-55

Front seat, Front seat adjustment 1-3

Fuel

- Capacities and recommended fluids/lubricants 10-2
- Fuel economy 5-153
- Fuel filler cap 3-28
- Fuel filler door 3-28
- Fuel information 10-3
- Fuel octane rating 10-3
- Gauge 2-10

Fuel Efficient Driving Tips 5-152

Fuses 8-17

Fusible links 8-17

G

Gas cap 3-28

Gauge

- Engine coolant temperature gauge 2-9
- Fuel gauge 2-10
- Odometer 2-8
- Speedometer 2-8
- Tachometer 2-9

General maintenance 9-2

Glove box 2-70

GRAVEL mode 5-30

H

Hazard warning flasher switch 6-2

Head restraints 1-12

Head-Up Display (HUD) 2-43

Headlights

 Bulb replacement 8-22

 Headlight switch 2-54

Heated seats 2-61

Heated steering wheel 2-60

Heater

 Heater and air conditioner operation ... 4-28

Height memory function 3-27

Hill Descent Control (HDC) 5-162

Hill start assist system 5-161

Hood release 3-19

Hook

 Coat hook 2-72

 Luggage hook 2-72

Horn 2-60

I

Ignition switch 5-13

Ignition switch positions 5-14

Immobilizer system 2-47

Indicator

 Lights 2-16

 Multi-information display 2-21

Inside mirror 3-33

Inspection/maintenance (I/M) test 10-33

Instrument brightness control 2-11

Instrument panel 2-4

Interior light replacement 8-23

Interior light switch 2-80

Interior lights 2-80

ISOFIX child restraint 1-29

J

Jump starting 6-12

K

Key

 Ignition switch positions 5-14

Keyless entry

 With F.A.S.T.-key

 (See F.A.S.T.-key) 3-15

Keys 3-2

 Free-hand Advanced Security

 Transmitter (F.A.S.T.-key) 3-7

L

Labels

 Air conditioner specification label ... 10-13

 Airbag warning labels 1-70

 Emission control information label ... 10-12

 Engine serial number 10-12

 F.M.V.S.S./C.M.V.S.S.

 certification label 10-12

Tire and loading

 information placard 10-12

 Vehicle identification

 number (VIN) 10-11

Lane Departure Prevention (LDP) 5-38

Lane Departure Warning (LDW) 5-33

Lane Keep Assist (LKA) 5-117

LATCH system 1-29

Liftgate 3-20

 Liftgate close and lock function 3-26

 Liftgate release lever 3-27

 Operating manual liftgate 3-21

 Operating power liftgate 3-22

Light

 Bulb replacement 8-22

 Dome lights 2-81

 Fog light switch 2-59

 Headlight switch 2-54

 Headlights bulb replacement 8-22

 Indicator lights 2-16

 Interior lights 2-80

 Map lights 2-80

 Rear personal lights 2-81

 Replacement 8-22

 SRS airbag warning light 1-71

 Vanity mirror lights 2-81

 Warning/indicator lights and

 audible reminders 2-13

Lights, Exterior and interior

 light replacement 8-23

Loading information (See vehicle loading information) 10-15

Lock

- Automatic door locks 3-6
- Door locks 3-4
- Power door lock 3-4

Low tire pressure warning 2-34

Low tire pressure warning (Low tire pressure) 2-34

Low tire pressure warning light 2-17

Low tire pressure warning system (See Tire Pressure Monitoring System (TPMS)) 5-6

Luggage compartment 2-69

Luggage hooks 2-72

M

Maintenance

- Battery 8-11
- General maintenance 9-2
- Inside the vehicle 9-3
- Maintenance precautions 8-2
- Maintenance requirements 9-2
- Outside the vehicle 9-2
- Seat belt maintenance 1-24

Malfunction indicator light (MIL) 2-18

Manual front seat adjustment 1-3

Map lights 2-80

Master warning light (red) 2-15

Master warning light (yellow) 2-19

Meters and gauges 2-5

- Instrument brightness control 2-11

MI-PILOT Assist 5-90

MI-PILOT Assist with Navi-link 5-90

- Speed Adjust by Route 5-110
- Speed Limit Assist 5-108

Mirror

- Door mirrors 3-34
- Inside mirror 3-33
- Vanity mirror 3-37

Moving Object Detection (MOD) 4-23

MUD mode 5-30

Multi Around Monitor 4-9

Multi-information display 2-21

- How to use the multi-information display 2-21

Multi-information display warnings and indicators 2-33

- Settings 2-23
- Startup display 2-22

N

Neutral hold mode 5-20

New vehicle break-in 5-151

NORMAL mode 5-29

O

Odometer 2-8

Off-road recovery 5-10

Oil

- Capacities and recommended fluids/lubricants 10-2
- Changing engine oil and filter 8-6
- Checking engine oil level 8-6
- Engine oil 8-6
- Engine oil viscosity 10-5

Other lights 2-19

Outside air temperature 2-43

Overheat, If your vehicle overheats 6-14

P

Panic alarm 3-17

Parking

- Brake break-in 5-157
- Parking brake 5-23
- Parking on hills 5-155

Parking brake

- Electric parking brake warning light ... 2-14

Parking sensor system 5-164

Parking sensor system settings 5-166

Personal Display 2-22

Phone

- Bluetooth® Hands-Free Phone 4-2
- Car phone or CB radio 4-34

Power

- Electric power steering 5-156
- Power door lock 3-4
- Power outlet 2-63
- Power windows 2-75

Power panoramic sunroof and sunshade 2-78
 PR25DD engine model 8-3
 Precautions
 Braking precautions 5-156
 Child restraints 1-27
 Cruise control 5-69
 Driving safety 5-11
 Maintenance 8-2
 On-pavement and off-road driving 5-10
 Seat belt usage 1-16
 SRS 1-47
 When starting and driving 5-5
 Predictive Forward Collision
 Warning (PFCW) 5-135
 Pull-up type sunshade (rear door) 3-33
 Push starting 6-14
 Push-button ignition switch 5-13

R

Radio
 Car phone or CB radio 4-34
 Rain-sensing auto wiper system 2-49
 Rapid air pressure loss 5-10
 Readiness for inspection/maintenance (I/M) test 10-33
 Rear AEB system limitations 5-148
 Rear Automatic Emergency Braking (Rear AEB) 5-146

Rear Automatic Emergency Braking (Rear AEB) system OFF warning light 2-19
 Rear Cross Traffic Alert (RCTA) 5-62
 Rear door lock, Child safety rear door lock 3-6
 Rear parking sensor system 5-169
 Rear personal lights 2-81
 Rear Seat Alert 2-62
 Rear window wiper and washer switch .. 2-51
 Rearview camera 4-2
 Recorders, Event data 10-34
 Registering in another country 10-11
 Remote keyless entry function, For F.A.S.T.-key 3-15
 Reporting Safety Defects 10-31
 Rollover 5-9
 Roof rail 2-74

S

S-AWC (Super-All Wheel Control) 5-153
 Safety
 Child seat belts 1-24
 Reporting Safety Defects 10-31
 Towing safety 10-23
 Seat adjustment
 Front manual seat adjustment 1-3
 Front seats 1-3
 Seat belt(s)
 Child safety 1-24

Front seat belt warning light and chime 2-15
 Infants 1-25
 Injured persons 1-20
 Larger children 1-25
 Precautions on seat belt usage 1-16
 Pregnant women 1-20
 Seat belt cleaning 7-6
 Seat belt clip 1-23
 Seat belt extenders 1-23
 Seat belt maintenance 1-24
 Seat belt warning light and chime 1-19
 Seat belts 1-16
 Seat belts with pretensioners 1-69
 Shoulder belt height adjustment 1-22
 Small children 1-25
 Three-point type with retractor 1-20
 Seat(s)
 Heated seats 2-61
 Seats 1-2
 Second row seats 1-6
 Security system (Anti-theft engine immobilizer), Engine start 2-47
 Security system, Anti-theft alarm system 2-46
 Servicing air conditioner 4-33
 Shifting
 CVT (Continuously Variable Transmission) 5-17
 Shoulder belt height adjustment, For front seats 1-22

SNOW mode 5-30

Soft bottle holders 2-69

SOS switch 2-67

Spark plugs 8-13

Speed Adjust by Route (MI-PILOT Assist with Navi-link) 5-110

Speed Limit Assist (MI-PILOT Assist with Navi-link) 5-108

Speedometer 2-8

SRS

 Precautions on SRS 1-47

SRS airbag deployment conditions 1-65

SRS airbag warning light 1-71, 2-15

Starting

 Before starting the engine 5-16

 Jump starting 6-12

 Precautions when starting and driving 5-5

 Push starting 6-14

 Starting the engine 5-16

Status light, Front passenger airbag 1-55

Steering

 Electric power steering 5-156

 Heated steering wheel 2-60

 Tilt/telescopic steering 3-31

Storage 2-68

Sunglasses holder 2-71

Sunroof 2-78

Sunshade (rear) 3-33

Sunvisors 3-32

Supplemental Restraint System (SRS) ... 1-47

Switch

 Auto Headlight switch 2-54

 Electric rear window and door mirror defroster switch 2-52

 Fog light switch 2-59

 Hazard warning flasher switch 6-2

 Headlight switch 2-54

 Power door lock switch 3-6

 Turn signal switch 2-59

T

Tachometer 2-9

TARMAC mode 5-30

Temperature gauge, Engine coolant temperature gauge 2-9

Theft (Anti-theft engine immobilizer), Engine start 2-47

Three-way catalyst 5-5

Tilt/telescopic steering 3-31

Tire Markings 8-26

Tire pressure, Low tire pressure warning light 2-17

Tire repair kit 6-3

Tires 8-24

 Flat tire 6-3

 Low tire pressure warning system 5-6

 Tire and loading information placard 10-12

 Tire chains 8-33

 Tire checking before driving 8-25

 Tire inflation pressures 8-29

Tire maintenance 8-31

Tire pressure monitoring system (TPMS) 5-6, 6-3

Tire rotation 8-31

Tread wear indicator 8-31

Uniform tire quality grading 10-30

Wheel/tire size 10-8

Tonneau cover 2-73

Towing

 Tow truck towing 6-16

 Towing a trailer 10-19

 Towing safety 10-23

TPMS, Tire pressure monitoring system .. 5-6

 TPMS with Tire fill notification 5-9

TPMS, Tire pressure warning system 6-3

Traffic Sign Recognition 5-30

Trailer towing 10-19

Transmission

 Continuously Variable Transmission (CVT) fluid 8-9

 Driving with CVT (Continuously Variable Transmission) 5-17

Transmitter, With F.A.S.T.-key (See F.A.S.T.-key) 3-15

Traveling or registering in another country 10-11

Trip computer 2-41

Turn signal switch 2-59

U

Underbody cleaning 7-3
 Uniform tire quality grading 10-30
 USB (Universal Serial Bus)
 charging outlet 2-64

V

Vanity mirror 3-37
 Vanity mirror lights 2-81
 Variable voltage control system 8-12
 Vehicle
 Active stability control (ASC) 5-159
 Dimensions and weights 10-9
 Identification number (VIN) 10-11
 Loading information 10-15
 Recovery (freeing a stuck vehicle) 6-19
 Security system 2-46
 Ventilators 4-26

W

Warning
 Hazard warning flasher switch 6-2
 Lights 2-13
 Low tire pressure warning 2-34
 Multi-information display 2-21
 Predictive Forward Collision
 Warning (PFCW) 5-135
 Tire pressure monitoring
 system (TPMS) 5-6, 6-3

Warning lights, indicator lights and
 audible reminders 2-12
 Warning labels, Airbag warning
 labels 1-70
 Warning light
 Anti-lock braking system (ABS)
 warning light 2-16
 Brake warning light 2-13
 Electric parking brake
 warning light 2-14, 2-17
 Electric power steering
 warning light 2-16
 Electric shift control system
 warning light 2-14
 Front seat belt warning light
 and chime 2-15
 Low tire pressure warning light 2-17
 Seat belt warning light and chime 1-19
 SRS airbag warning light 1-71, 2-15
 Warranty, Emission control
 system warranty 10-31
 Washer switch
 Rear window wiper and
 washer switch 2-51
 Wiper and washer switch 2-48
 Washing 7-2
 Waxing 7-2
 Weights (See dimensions and
 weights) 10-9
 Wheel/tire size 10-8

Wheels and tires
 Cleaning aluminum wheels 7-3
 When refueling from a portable
 fuel container 3-31
 Window washer fluid 8-10
 Window(s)
 Cleaning 7-3
 Power windows 2-75
 Wiper
 Rain-sensing auto wiper system 2-49
 Rear window wiper and
 washer switch 2-51
 Rear window wiper blade 8-16
 Wiper and washer switch 2-48
 Wiper blades 8-15
 Wiper and washer switch 2-48
 Wireless charger 2-64

MEMO

GAS STATION INFORMATION

FUEL INFORMATION:

Use unleaded regular gasoline with an octane rating of at least 87 AKI (Anti-Knock Index) number (Research octane number 91).

CAUTION

- Using a fuel other than that specified could adversely affect the emission control system, and may also affect warranty coverage.
- Under no circumstances should a leaded gasoline be used, because this will damage the three-way catalyst.
- Do not use E-15 or E-85 fuel in your vehicle. Your vehicle is not designed to run on E-15 or E-85 fuel. Using E-15 or E-85 fuel in a vehicle not specifically designed for E-15 or E-85 fuel can adversely affect the emission control devices and systems of the vehicle. Damage caused by such fuel is not covered by the Mitsubishi Motors new vehicle limited warranty.
- Do not use fuel that contains the octane booster methylcyclopentadienyl manganese tricarbonyl (MMT). Using fuel containing MMT may adversely affect vehicle performance and vehicle emissions. Not all fuel dispensers are labeled to indicate MMT content, so you may have to consult

your gasoline retailer for more details. Note that Federal and California laws prohibit the use of MMT in reformulated gasoline.

- U.S. government regulations require ethanol dispensing pumps to be identified by a small, square, orange and black label with the common abbreviation or the appropriate percentage for that region.

For additional information, see “Capacities and recommended fluids/lubricants” (P.10-2).

ENGINE OIL RECOMMENDATION:

See “Capacities and recommended fluids/lubricants” (P.10-2) for engine oil and oil filter recommendation.

COLD TIRE PRESSURES:

The label is typically located on the driver side center pillar. For additional information, see “Tires” (P.8-24).

NEW VEHICLE BREAK-IN PROCEDURES RECOMMENDATION:

During the first 1,200 miles (2,000 km) of vehicle use, follow the recommendations outlined in the “Break-in schedule” (P.5-151) of this Owner’s Manual. Follow these recommendations for the future reliability and economy of your new vehicle.